



Industry

Removing dust from the workplace is not just a working environment and health issue, it is also a business issue. The cleaner the working environment, the better the end result.

We call it Healthy Business.

Healthy Business

Dustcontrol

®

Dustcontrol – Technology for Healthy Business

Removing dust from the workplace is not just a working environment and health issue, it is also a business issue. The cleaner the working environment, the better the end result. We call it “Healthy Business”.

What we offer

Dustcontrol manufactures mobile dust extractors for industrial and construction use, fixed extraction systems, peripheral equipment and accessories. We help companies all over the world to achieve a cleaner working environment. Our development department and production facilities are located in Sweden.

Using one of our solutions, you can extract dust, fumes, chips, oil spillages and other harmful substances, right at their source. The result is efficient production. A healthy working environment results in less absence due to illness, more efficient production, less downtime and better production quality.

You will find us in many different types of industries where a clean working environment is necessary. Dustcontrol supplies a complete range of products and accessories for small and large companies alike. For example, we supply advanced cleanroom solutions for the pharmaceutical and electronics industries, mobile dust extractors of various sizes for construction and rental companies, and central extraction systems for the automotive and newspaper printing industries.

All of our systems are unique and tailored to each individual company's specific requirements.

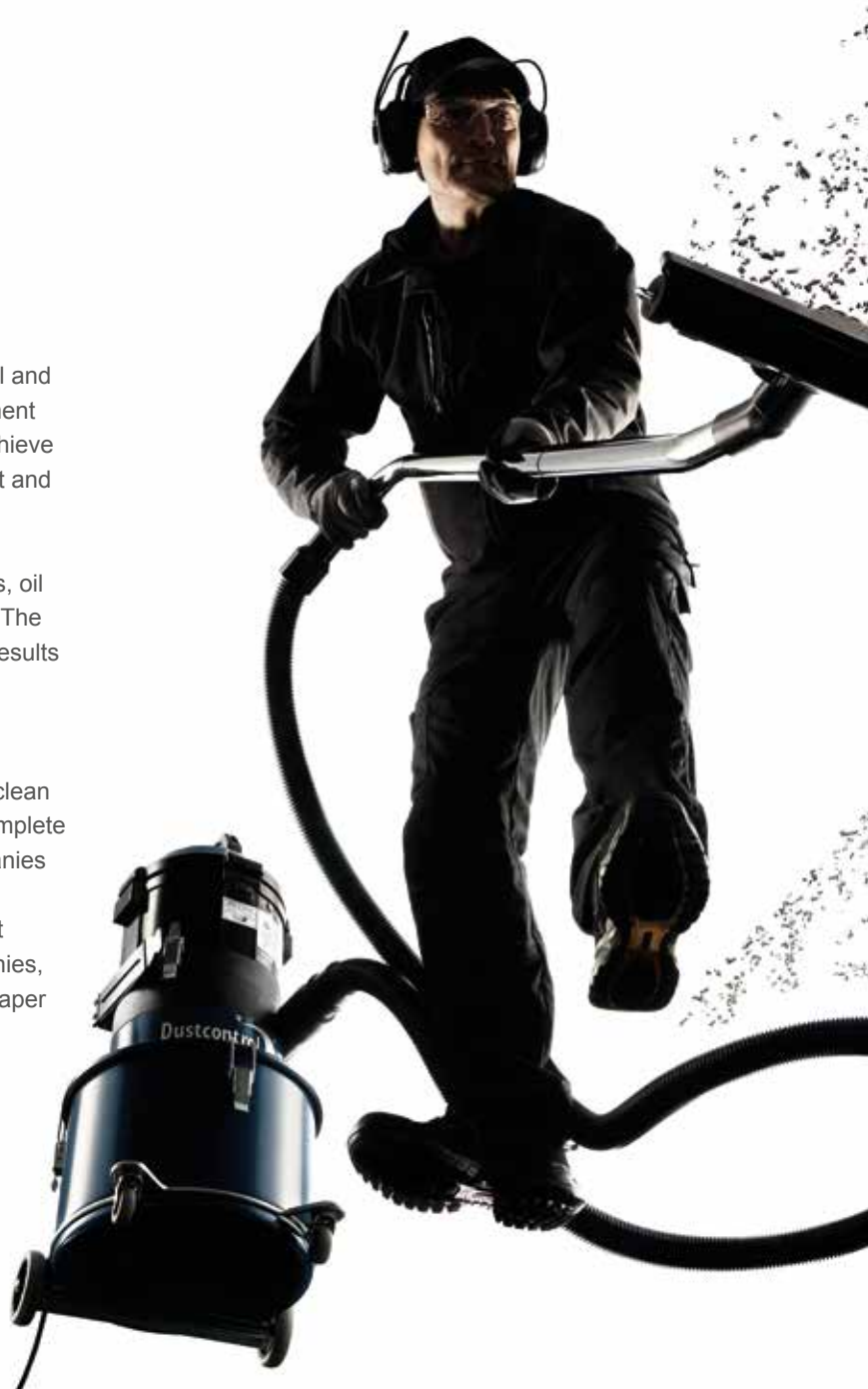

Customer Focus

Dustcontrol was founded in 1972, with the idea of manufacturing extraction systems to capture dust and other pollutants at the source. We work closely with our customers, which means that we are always up to date regarding the requirements, regulations and working conditions in different types of workplace. We supply products that meet these ever-changing needs.

But it is not only products that we provide. We also provide the answers to questions such as: How can you capture and extract different kinds of particles and pollutants in the best possible way for your business? How do you deal with waste that can be recycled or reused?

With Dustcontrol as your business partner, you will get the answers to these and any other questions that you may have.

Whatever the conditions, we develop a source extraction solution that is right for you and your business.

Dustcontrol AB makes every effort to maintain the accuracy and quality of the information provided in this catalogue. However, Dustcontrol AB cannot guarantee and assumes no legal liability or responsibility for the accuracy or completeness of the information provided. The information contained on this catalogue is for general guidance only.

The copyright of all content on this catalogue is owned by Dustcontrol AB. No part of the Dustcontrol AB catalogue may be changed, reproduced, stored in or transmitted on any website or medium without the prior written permission of Dustcontrol AB. Requests to republish any material must be sent to info@dustcontrol.se. In case of any questions or remarks, feel free to contact us.

Published by Dustcontrol AB 2016 © www.dustcontrol.com

Service & Expertise

Our sales organisation comprises experienced technicians with specialist skills in their areas of expertise. If you need a mobile solution, we will come to your site and show you how it works. In the case of stationary installations, we can design and dimension the entire system to fully match your needs. We can take care of installation, commissioning and documentation, as well as planning a maintenance and service schedule.

We offer a complete service package, including accessories and spare parts. We manufacture and customise portable dust extractors with very high levels of filtration, in which we use our proprietary filters that have set the industry standard.

All our mobile machines are equipped with a fine filter and a HEPA filter (H13) that clean the exhaust air to 99.95%. These high-efficiency filters also have a long service life, which not only results in cleaner air, but also low filter costs.

As well as being responsible for delivery and installation, our project managers also train the personnel who will be working with our products and systems. In most countries, we have our own team of qualified installers with in-depth knowledge of our products.

With the help of Dustcontrol, you will achieve both a cleaner working environment and a healthy business.

Dustcontrol AB

140 employees.

Founded in 1972.

Head office and factory
in Norsborg, Sweden.

The company is family-owned.

Turnover of approx. SEK 280 million.

Subsidiaries in The United Kingdom,
Germany, Austria, USA and Finland.

Distributors in Europe,
Asia, Australia and
North & South America.

Healthy Business
Dustcontrol

Dustcontrol Worldwide



AT

Dustcontrol Ges.m.b.H.
Gradnerstrasse 122
AT-8054 Graz
Telephone : +43 316 428 081
info@dustcontrol.at
www.dustcontrol.at



AU

Archquip - All Preparation Equipment
130 Lytton Rd
AU-4171 Bulimba QLD
Telephone: +61 7 3217 9877
www.allpreparationequipment.com.au



BENELUX

Dust Solutions BV
Eiffelstraat 44
8013 RT Zwolle
Telephone: +31(0)38-2020154
Fax: +31(0)38-2020157



BGR

Metaltech14 Ltd
7 Parva str
4207 Kadievo
Telephone +359 888 255 102
+359 889 999 593
metaltex14@abv.bg
www.dustcontrolbg.com



CA

Dustcontrol Canada Inc.
664 Welham Road
CA-Barrie, Ontario L4N 9A1
Telephone: +1 877 844 8784
info@dustcontrol.ca
www.dustcontrol.ca



CH

Rosset Technik
Maschinen Werkzeuge AG
Ebersmoos
CH-6204 Sempach-Stadt
Telephone: +41 41 462 50 70
info@rosset-technik.ch
www.rosset-technik.ch



CHN

Suzhou Dustcollect Filtration Technology Co. Ltd.
Room 218, Building B, No.1368
Wuzhong Avenue, Wuzhong District,
Suzhou City, Jiangsu Province, China
Telephone +86 180 6800 0359
wang@dustcollect.cn
www.dustcollect.cn



DE

Dustcontrol GmbH
Siedlerstraße 2
DE-71126 Gäufelden-
Nebringen
Telephone: +49 70 32-97 56 0
info@dustcontrol.de
www.dustcontrol.de



DK

Dansk Procesventilation ApS
Vangeleddet 7
DK-2670 Greve
Tel: +45 61 270 870
info@dansk-procesventilation.dk
www.dansk-procesventilation.dk



EE

G-Color Baltic OÜ
Ülase 13
EE-10613 Tallinn
Telephone: +372 682 5919
sales@g-color.ee
www.g-color.ee



ES

Barin, s.a.
C/ Cañamarejo, No 1
Poligono Industrial
Rio de Janeiro
ES-28110 Algete - Madrid
Telephone: +34 91 6281428
info@barin.es
www.barin.es



FI

Dustcontrol FIN OY
Valuraudankuja 6
FI-00700 Helsinki
Telephone: +358 9-682 4330
dc@dustcontrol.fi
www.dustcontrol.fi



FR

SMH Equipements
- Construction
Lieu Dit « La Fontaine »
FR-28630 Berchères Les Pierres
Telephone: +33 (0)2 37 26 00 25
info@abequipements.com
www.smhequipements.com



HU

Vandras Kft
Kossuth L. u. 65 III.29
HU-1211 Budapest
Telephone: +36-1-427-0322
Mobile: +36-20-9310-349
vandras@t-online.hu
www.vandras.hu



IN

Advance Ventilation Pve Ltd.
8th Floor, NDM-2, Building
D-1,2,&3, Netaji Subhash Place
IN-Pitampura, New Delhi-110 034
Telephone: +91 11 47243296-298
sales@advanceventilation.com
www.advanceventilation.com



IRN

BioMedoc International Group
Rutherford House, Pencroft way,
Manchester Science Park,
Manchester, M15 6SZ, UK
Telephone: +44 161 820 8441
dr.bohloli@biomedoc.com
www.biomedoc.com



IT

Airum srl
via Maestri del Lavoro 18
Roveri-2
IT - 40138 Bologna
Telephone: +39 (0)516 025 072
info@airum.com
www.airum.com



KR

E. S. H Engineering Co.
671-267 Sungsu1ga 1dong
Sungdonggu (P.O)133-112
KR-Seoul Korea
Telephone: +82 (0)2 466 7966
k.u.lee@hanmail.net
www.esheng.co.kr



LT

UAB Hidromega
Mainų g. 23
LT - 94101 Klaipėda
Telephone: +370 677 10254
info@hidromega.lt
www.hidromega.lt



LV

SIA Reaktivs
Rīgas iela 113,
Salapils, LV-2169
Telephone: +371 20282200
reaktivs@reaktivs.lv
www.reaktivs.lv



MY, ID

Blöndal Städa (M) Sdn. Bhd.
Blöndal Building, Jalan Penyarir,
Section U1, Off jalan Glenmarie,
MY-40150 Shah Alam
Telephone: +603 -5569 1006
info@stada.com.my
www.stada.com.my



NO

Teijo Norge A.S
Husebysletta 21
Postboks 561
NO-3412 Lierstranda
Telephone: +47 3222 6565
firmapost@teijo.no
www.teijo.no



PE

Efixo
Calle 3 MZ. N LT. 15
Parque Industrial El Asesor
Ate, Lima, PE – Perú
Telephone: (0051) 583-8541
Cell: (0051) 968-140-066
Email: contacto@efixo.pe
http://www.efixo.pe



PL

Bart Sp. z. o.o.
ul. Będzińska 41/1
PL-41-205 Sosnowiec
Telephone: +48 32 256 22 33
info@bart-vent.pl
www.bart-vent.pl



PT

Metec-Mecano Técnica, Lda.
Campo Pequeno, 38
PT-1000-080 Lisboa
Telephone: +351 21 7970291
geral@metec.pt
www.metec.pt



RU

SovPlym Ltd
Revolution Highway, 102-2
RU-195279, St Petersburg
Telephone: +7-812-33-500-33
kia@sovplym.spb.ru
www.sovplym.com



SE

Dustcontrol AB
Box 3088
Kumla Gärdsväg 14
SE-145 03 Norsborg
Telephone: +46 8 531 940 00
support@dustcontrol.se
www.dustcontrol.com



SG

Blondal (S) Pte Ltd
52 Ubi Ave 3
Frontier Building
#03-29
SG-Singapore 408867
Telephone: +65 6741 7277
Info@stada.com.my
www.stada.com.my



TR

Ventek Mühendislik Ltd
Adnan Kahveci Bulvarı
Ünverdi İş merkezi Nr 73
Dr: 30 Bahçelievler
TR-Istanbul
Telephone: +90 212 4415596-97
info@ventek.com.tr
www.ventek.com.tr



UAE

Global Enterprises Trading Co L.L.C.
P O Box 27914
Mussafah No. M9, Plot 50
AE-Abu Dhabi
Telephone: +971-2-555 4733
sales@globalentco.com
www.globalentco.com



UK

Dustcontrol UK Ltd.
7 Beaufort Court, Knowlhill,
Milton Keynes MK5 8HL
England - GB
Telephone: +44 1327 858001
sales@dustcontrol.co.uk
www.dustcontrol.co.uk



US

Dustcontrol Inc.
6720 Amsterdam Way
US-Wilmington NC 28405
Telephone: +1 910-395-1808
info@dustcontrolusa.com
www.dustcontrol.us

Index

1	Healthy Business by Dustcontrol	6-16
2	Stationary Vacuum Systems	17-22
3	Vacuum Producers	23-38
4	Filter Units	39-48
5	Pre-Separators	49-68
6	Compact Vacuum Systems	69-80
7	Tubing System	81-96
8	Work Station Equipment	97-110
9	Control Systems	111-116
10	Mobile Dust Extractors	117-142
11	Accessories and Consumables	143-174

Technology for Healthy Business

Let Dustcontrol help you to achieve both a cleaner working environment and a healthy business.

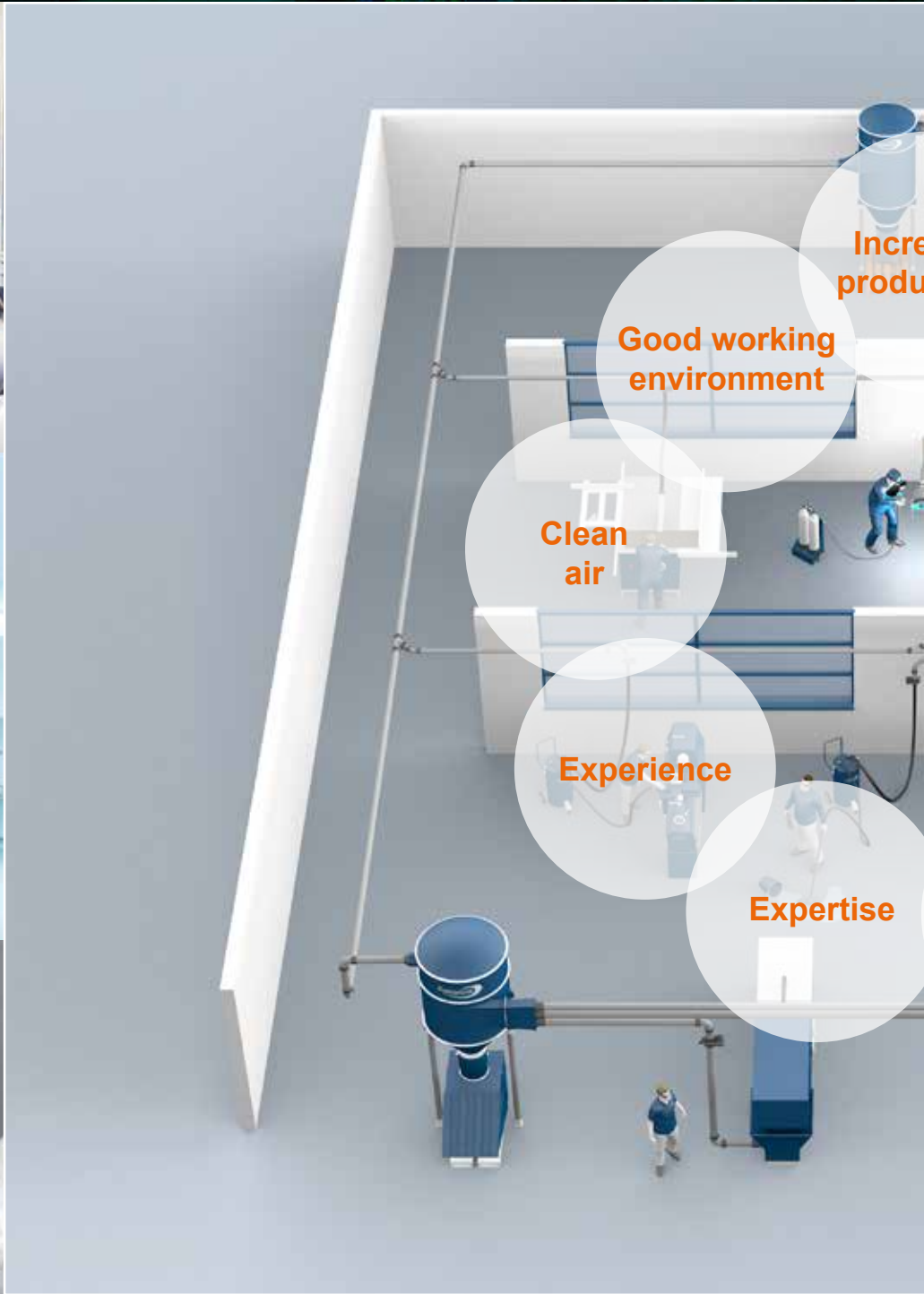

Solutions for a large variety of businesses such as food, pharmaceuticals, manufacturing, aerospace, transit, waste handling, construction etc.

Increased activity

Efficiency

Time

Profitability

Service

Healthy Business
Dustcontrol





Food Industry

Nutrition

Food industry has special requirements. Control of components and equipment used in production is extreme, with a special focus on migratory risk, surface finish and often antistatic properties.

Dustcontrol designs and install complete source extraction systems in close cooperation with the customer. Each system is unique and conforms to EU1935/2004 and FDA. We let independent test institutes certify a large part of the components.

Our source extraction system can be fully integrated in the production process for optimal recycling or used as a central vacuum cleaning system.

To help the user to separate the cleaning equipment to be used with a certain product, we have a unique colour coding of cleaning accessories.



The combination of colour coding and anti-static attributes help to increase production security, efficiency and health and safety issues.



Food Industry

Bakery

Flour dust is a hazardous substance. Workers in baking related jobs may inhale flour dust when it becomes airborne. Runny nose, runny eyes, wheezing, shortness of breath, sneezing, asthma or cough are some of the health problems which can develop over time. Flour dust can also cause an explosion.

Dustcontrol designs systems for bakeries, using our experience of source extraction in hazardous environments.

A source extraction point is placed at each area where flour is used. In that way the pollution is captured directly at the source instead of going into the air. All equipment and fixtures are frequently cleaned of flour and dust with highly efficient vacuum cleaning accessories.

To further purify the air from health hazardous flour dust, air cleaners (DC AirCube) may be installed as a complement.

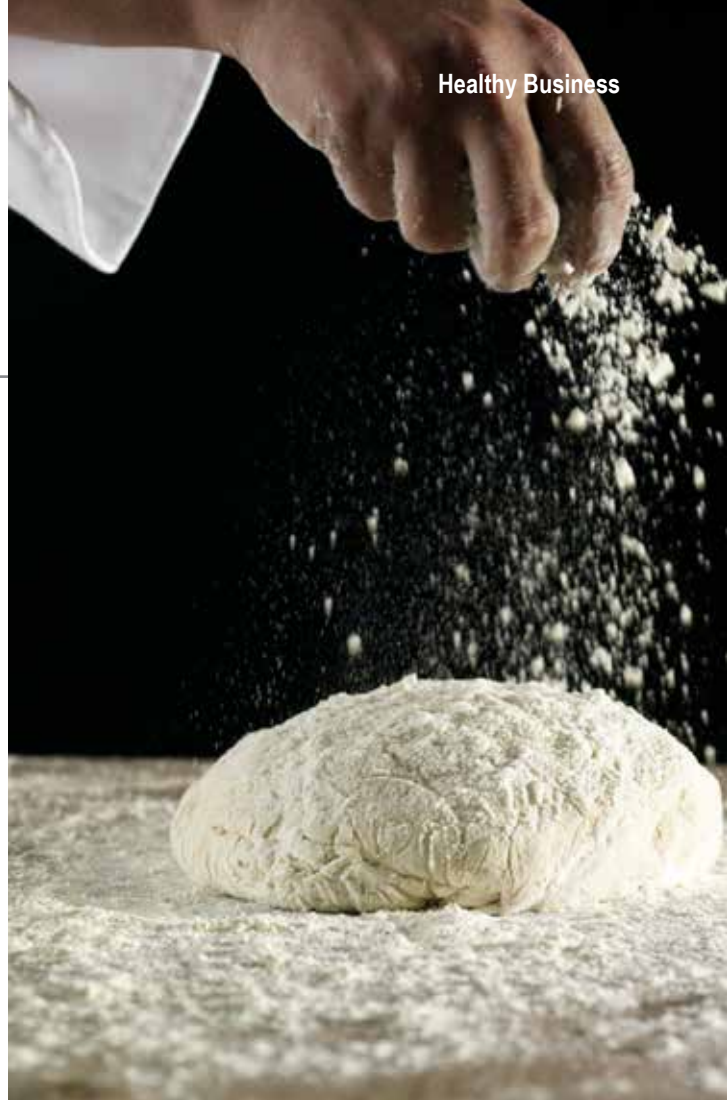



Shipbuilding and Composite

Composites have many unique qualities and are used in an increasing number of industries including automotive, marine, aviation and wind turbine. This increase use of composites and exotic materials has resulted in problems for personnel as well as production itself. Composite dust has a very low density and stays in the air for a long time. It penetrates into the trachea and lungs and promotes allergies, asthma and respiratory ailments. Composite dust accumulates and causes problems in computers and other electronic equipment.

Fixed systems from Dustcontrol are installed and used for cleaning and grinding with hand held power tools with suction casings. Flexibility increases and eliminates the need for dedicated grinding rooms and reduces time and costs for cleaning. It increases productivity by improving the operator's visibility and working conditions are safer.



Mechanical Industry

The manufacturing industry has many requirements for vacuum cleaning and extraction from the point of production. Large quantities of dust, debris, metal chips and strips can be produced and need to be transported away; sometimes for profitable recycling.

Hard-metal – Tungsten Carbide

Tungsten carbides have a wide range of applications in many industry sectors such as metal machining, wear parts for mining and oil industries, metal forming tools, cutting tips for saw blades. Cobalt is used as a binding material when manufacturing hard metals. The material is classified as carcinogenic.

Dustcontrol has extensive experience in lowering the exposure dust. We install custom made suction casings directly on production machinery, adapt control systems to production processes and apply the most efficient solutions to ATEX/NFPA standards when required.

Foundry

Dustcontrol's abrasive resistant EPDM tubing system can handle even high abrasion. Thanks to a radial ridge in the bend, the wearing is distributed over a larger area. The EPDM material has good noise reducing properties.

Dustcontrol has a lot of experience in source extraction in foundries. Hand held tools are equipped with suction casings to collect hazardous gases and scrap materials at source. A pre-separator is used to separate the lubricant from the metal chips from CNC machines. Pure metals can be recycled in the process. The Dustcontrol system is also used for cleaning and material transport.



Transit

The standard of our passenger transportation vehicles has risen and continues to rise. Public transport should be quick and convenient and passengers expect clean trains and buses. Our modern cleaning technology can be used to make these clean environments.

Vacuum cleaning floors and seats with a highly efficient suction system results in a much cleaner vehicle than with older technology. The vacuum system also takes care of collecting and transporting coarse waste. This leads to more efficient cleaning as every second of the cleaning time is valuable. Needless to say, ease of handling and good cleaning accessories play an important role.



Waste Handling and Incineration Facilities

Within waste management and incineration facilities there are several applications areas where modern source extraction and material transport systems can improve the overall operations and lead to cost savings.

Dustcontrol has provided many systems all over the world to filtrate and collect hazardous waste materials and transport them to their designated area. Pre-separators are also used to separate liquid from metals.

Incineration plant

A central system delivered by Dustcontrol takes care of the internal environment, mainly cleaning around the furnaces. Activated carbon is also transported and filtered by the system. The installation is designed and installed to comply with the European ATEX directive to minimise the risk of dust explosion.



Aviation and Automotive Industry

The aviation & automotive industry has several application areas where efficient source extraction and cleanliness is a must: FOD (foreign object debris) control, composite fabrication, wood handling, coating and painting, just to name a few.

Source extraction systems are built out of Dustcontrol standard or ATEX/NFPA components, many of them engineered and patented. Suction casings are developed to fit the equipment where dust is created, like grinding, drilling machines, sanders and saws. With a central vacuum system, the dust is collected in a container for easy disposal. Dustcontrol has a very extensive range of products, which provide reliable solutions with long product life and more efficient production.

In addition to offering a dustless environment for such tasks as drilling, sanding and grinding, the extraction system is used for cleaning tasks and extraction of residual materials during riveting and gluing. Also, sealant materials and chromium residual products are captured. The materials that are extracted are aluminium, GLARE (glass reinforced fibre metal laminate), carbon fibre, fibreglass, epoxy, polyester, aluminium alloys and titanium.



Pharmaceutical Industry

In the pharmaceutical industry it is necessary to protect products from what is commonly called particle contamination. Within the pharmaceutical industry this is important for several reasons. Even particulate that is invisible to the naked eye can carry bacteria. This can impair the transparency of liquids or block capillaries. The solution is to allow the sensitive parts of manufacturing to take place in special environments cleaned of airborne particulate. These clean rooms are graded into different cleanliness classes, depending on the manufacturing requirements.

Production Facility

Our solution. The clean room needs an efficient and reliable system for collecting and removing dust and other particulate. Just the presence of a human being in a clean room is enough to free microscopic particulate. Dustcontrol has many years of experience in manufacturing systems built to the high standards required in these clean room environments. The systems are based on proven techniques including source extraction and can be entirely customised according to the client's specifications.

Complete accessory range

Dustcontrol offers a complete range of different cleaning equipment, hoses, connections, and nozzles, which can easily be connected to the system, both in the clean room and other locations.

About airborne particles

Airborne particulate can be microscopic and still carry bacteria. Working in a clean room necessitates special equipment, which has to be antistatic and must not release dust particles.



Construction and Rental Industry

Dustcontrol has been designing systems for source extraction of hazardous dust such as asbestos, silica dust and quartz within the construction industry for close to 45 years. In keeping up with increased demands for cleanliness and efficiency, the interest for source extraction has been constantly growing.

Dustcontrol solutions minimise airborne dust, creating major health and safety advantages. They also lead to increased

productivity and massive reduction in clean-up time and expense; thus greater customer satisfaction and minimum interruption. All our portable units are equipped with a fine filter and HEPA H13 filter as standard.

The Dustcontrol construction units are a very popular choice for the Rental Industry due to their quality, long service life, availability of spare parts and wide range of accessories.



Visit www.dustcontrol.com for your Construction Catalogue!

Healthy Business

Dustcontrol®

Stationary Vacuum Systems

Substantial savings can be realised by installing a Dustcontrol system. Capture of the dust at source contributes to an improved working environment, higher productivity – shorter clean-up, cleaner process and improved product quality.



About Stationary Vacuum Systems

Dustcontrol's systems are used for three main purposes – source extraction, cleaning and material transportation. These three functions are often combined in a single extraction system.

Each system is unique and adapted to the production process any special requirements of energy saving, conformity to ATEX/NFPA directives, health and safety legislations.

It is helpful to view the extraction system as a supply system, just like those for electricity, compressed air etc. In some cases it can serve to solve major problems, but even if this is not the case, the high-efficiency cleaning equipment, the ability to collect and transport material away and the ability to capture pollutants right at the source will improve the day-to-day operations, year in and year out.





The Complete System for Healthy Business

1 Vacuum Producers

The vacuum producer is the heart of the system. Here the vacuum is created that drives the system. In Dustcontrol extraction systems, the vacuum level is generally from 6–40 kPa. Our normal source extraction and vacuum cleaning systems use turbopumps. This device has an ideally suited characteristic capacity for this type of system. Vacuum level increases as more resistance is presented, an important quality in minimising the possibility of blockages in the tubing system.

For applications involving fume and light dust, such as paper, radial blowers are used. These have larger air flows and operate at a lower, relatively constant vacuum level.

Our turbopumps and radial blowers have very high quality built-in silencing, see technical specifications.

2 Filter Units

An extraction system should always be equipped with a filter unit. Dustcontrol filter units separate coarse material in the cyclone body of the unit and fine dust in an internal arrangement of conical pleated cartridge filters. Pleated filters have very high filter areas in relation to their physical size. The filter units therefore have high capacity while maintaining compact overall dimensions.

Filters are cleaned with reverse pulse which results in very effective cleaning, long filter life and low maintenance.

Normally the filter units are equipped with a plastic bag for collection of the extracted material but other types of discharge arrangements can also be installed.

3 Pre-Separators

Pre-separators can be used in all applications where the extracted material is coarse or voluminous. These can be placed in the actual workplace for separate handling or recovery of the extracted material, or centrally.

Pre-separators separate material from the air flow using cyclonic action or with inertial separation. Inertial separators are generally configured as containers with the inlet and outlet in the same wall of the container. When the air flow changes direction abruptly, separation occurs for the particles with higher relative mass. When pre-separation is used to accommodate higher material volumes it is also important to consider the type of material discharge to be used. Dustcontrol offers a range of different standard options including; screw compaction, airlocks or container collection.

4 Tubing System

The tubing system transports the material from the point of collection to the central unit. Dust is generally abrasive, some more than others, therefore the standard material thickness of the tubing system is 1.5 mm. Applications with fume and light dust use reinforced spiral duct. Stainless tubing systems and extra abrasion resistant fittings are available.

Dustcontrol has a very comprehensive assortment of tubing fittings and installation hardware. This gives greater flexibility in design and installation of our tubing systems. Our mechanical jointing system makes alterations and additions very easy to carry out. Some cones, branch pipes and bends are available in EPDM and NBR-rubber, which are abrasive resistant and noise reducing.

5 Work Place Equipment

An extraction system is sized for only those outlets which are to be used simultaneously. This is in order to maximise efficiency and minimise the size of the central unit. All outlets must have some type of closure, either a flap valve or shutter valve. These can be manually actuated, such as flap valves or manual shutter valves, or automatically controlled for actuation only when extraction is required.

The Flexpipe can be used for fume extraction. High flexibility and small diameter allow it to be placed very close to the fume source. Overhead suspension arrangements such as swing-arms and hose reels can increase the usefulness of the system, increase ergonomics and minimise potential trip hazards from hose left on the floor.

When large volumes of material are to be introduced into the system, stainless floor funnels can be used from which the material is then extracted.

6 Accessories

A hose must have many qualities, the foremost for the operator however is flexibility. It should also be tough enough to withstand the abrasion created when transporting the extracted material. Hose selection should include consideration for abrasion, chemical and heat resistance as well as conductivity of static electricity.

Dustcontrol has a comprehensive assortment of hose types, diameters and hose connections. Cleaning tools, suction casings and special nozzles are those components that are actually used to capture the dust. The design and effectiveness of these will determine the efficiency and acceptance of the entire system. This demands a varied and complete assortment of specially designed products. Dustcontrol has that. If a standard product does not exist, we have the capacity to design and manufacture it.

7 Control Systems

Motor starters and system control panels control the operation of the system, operation of the vacuum producers and cleaning of the filter. A variety of other control functions can be installed as required.

Even with a rather basic control system, intelligent features can be included to clear coarse material in the main tubing runs or control vacuum production and therefore energy consumption according to actual requirements.

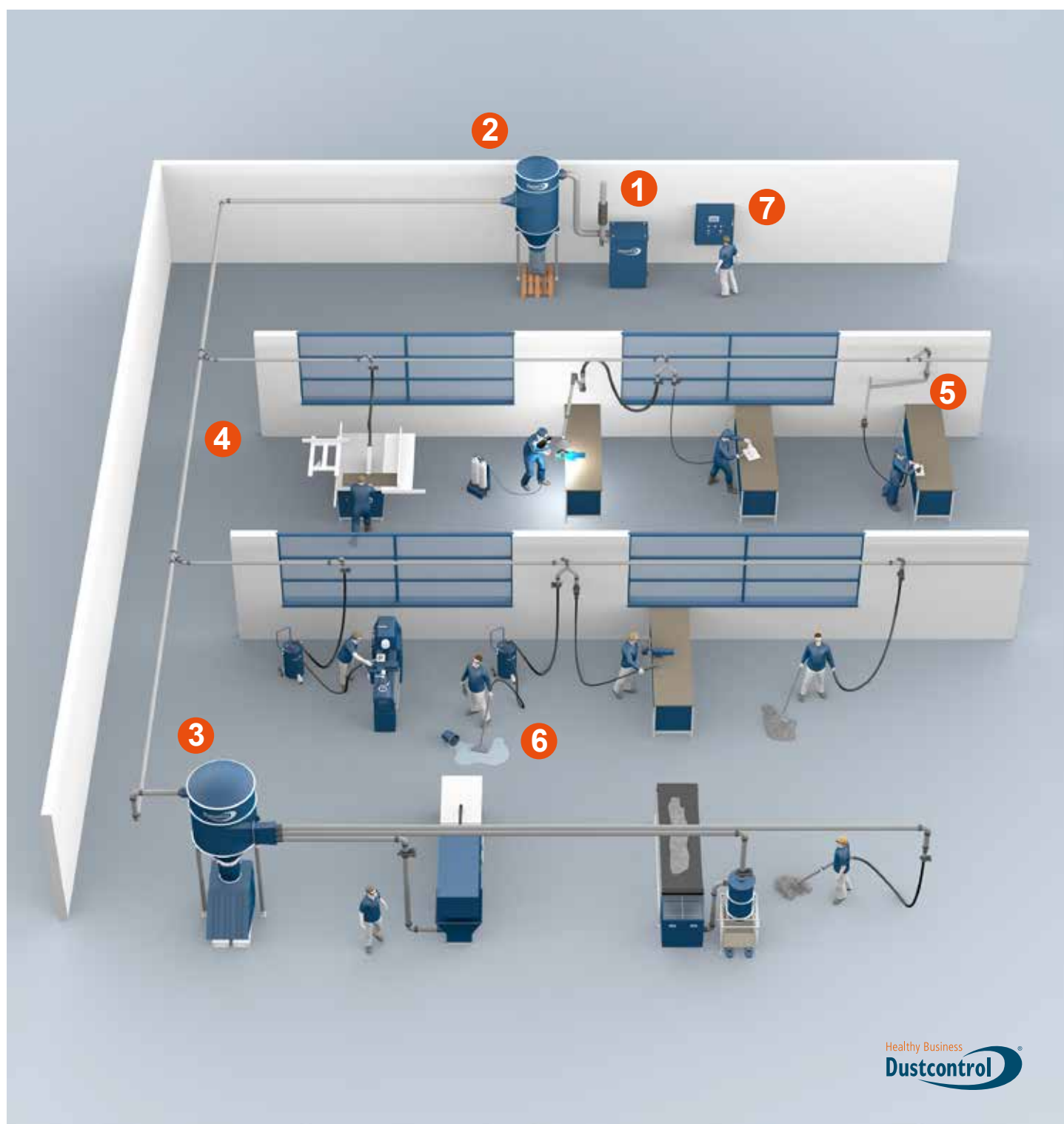

Healthy Business
Dustcontrol

To attain the desired efficiency and benefits with an extraction system, the system must be complete; from the suction casing to the vacuum producer to the control system. All the components of the system are equally important in implementing its functionality.

Equipment for Potentially Explosive Atmospheres



ATEX/NFPA-Systems

Dustcontrol has been operating in the field of environmental equipment for more than 40 years and has extensive experience in the equipment and systems for potentially explosive dust. Keeping the work environment clean and safe minimises the risk of explosion, maximises your production up-time, increases your product's quality and gives significant cost savings.

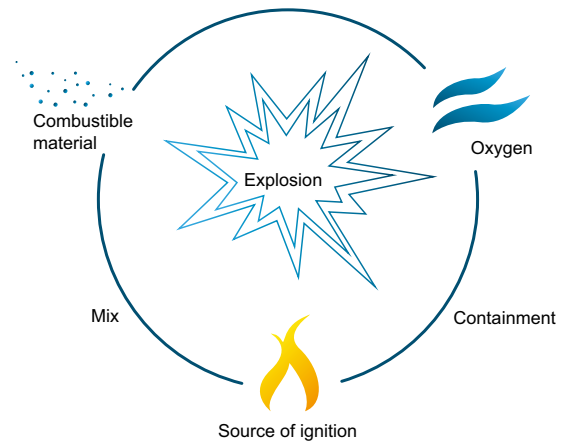

Dustcontrol supplies filter units designed to be installed in Zone 22 according to ATEX Directives 2014/34/EU.

Visit www.dustcontrol.com for a complete **ATEX System Guide**. Search for ATEX.

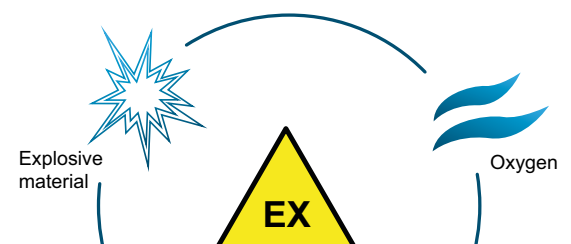

Healthy Business

Dustcontrol

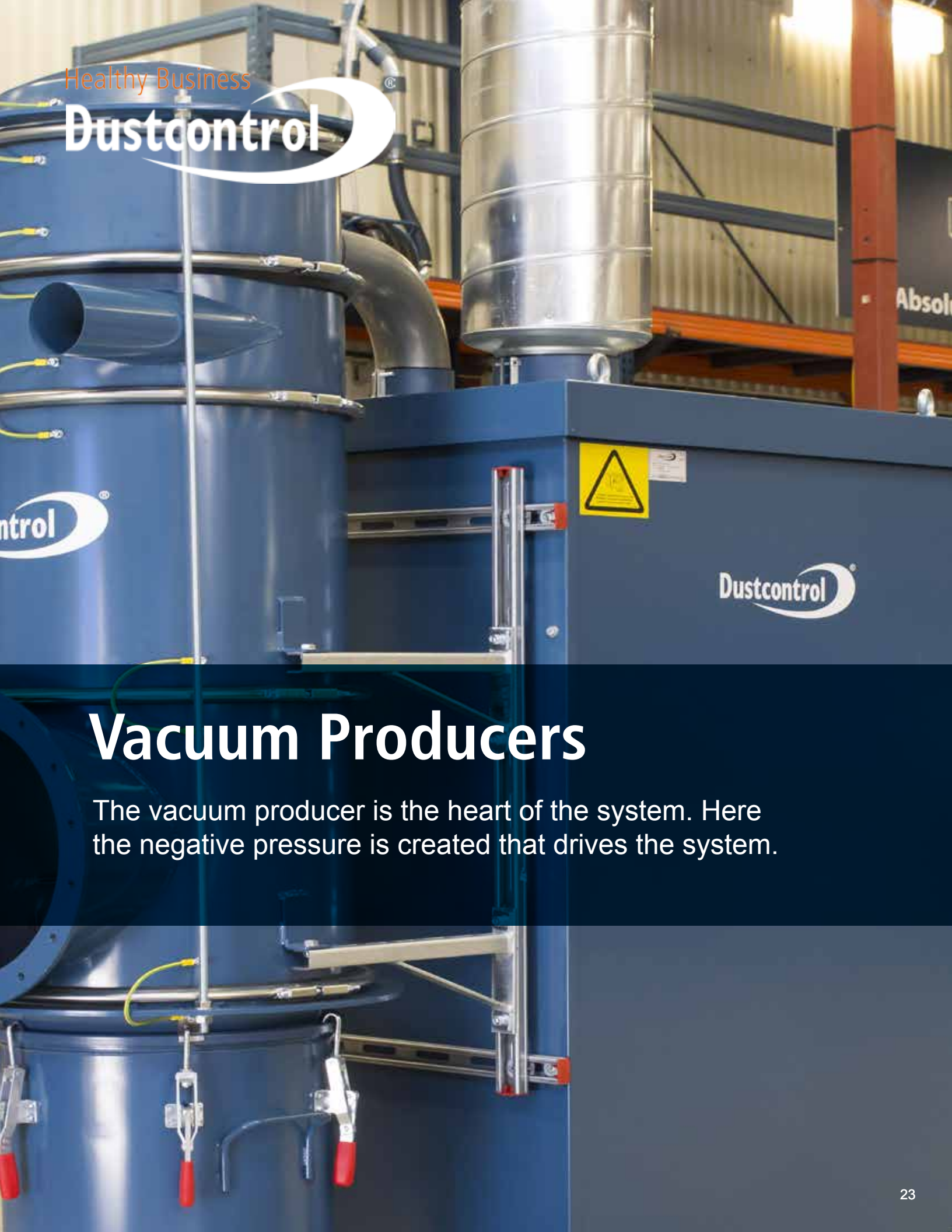

Vacuum Producers

The vacuum producer is the heart of the system. Here the negative pressure is created that drives the system.

About Vacuum Producers

The heart of the system

The vacuum producer is the heart of the system. Here, the negative pressure is created that drives the system. In Dustcontrol extraction systems, the vacuum level is generally from 6–40 kPa.

Our normal source extraction and vacuum cleaning systems use turbopumps. This device has an ideally suited characteristic capacity for this type of system. Vacuum level increases as more resistance is presented, an important quality in minimising the possibility of blockages in the tubing system. For applications involving fume and light dust, such as paper, radial blowers are used. These have larger air-flows and operate at a lower, relatively constant vacuum level. Our turbopumps and radial blowers have very high quality silencing, see technical specifications.

Turbopumps

Dustcontrol's turbopumps are regenerative blowers, both the direct and belt driven models. As the impeller rotates, centrifugal force moves the air from the root of the blade to the tip. Leaving the tip, air flows around the contour of the housing and is picked up at the root of the succeeding blade. The "closed" area of the housing between the outlet and inlet, forces the air to atmosphere. The many blades on the impeller create increasing stages of pressure generation and result in a very stable pressure differential capability. This pressure generation causes

heat to be generated naturally which dissipates in the air flow and through the blower housing. Noise reduction, particularly on the larger units is very effective. When two or more units are installed in parallel, they can be operated on demand for maximum efficiency and minimum energy consumption.

Radial Blowers

Dustcontrol fans are radial blowers, air is introduced at the center of the fan wheel and forced outward with centrifugal force toward the fan housing. These fans can be operated fully restricted in a "free-wheeling" condition without adverse effect and can therefore be operated without vacuum relief valves. The fans are designed for pressure and are overloading type units. They cannot be operated without being connected to the restriction of a tubing system. Operation above their maximum rated flow will result in overloading and the motor protection will trip out. To limit the power surge at start-up, install a shutter valve on the inlet which should be closed when the fan starts.

Dustcontrol's radial fans meet the ErP directive 2009/125/EC. The ErP, Energy related products, directive 2009/125/EC aims to lower the energy consumption for fans. Commission Regulation (EU) No 327/2011 states how to implement this directive. The efficiency requirements affect Dustcontrol's RAF-range.



Turbopumps Source Extractions, Cleaning, Pneumatic Transportation

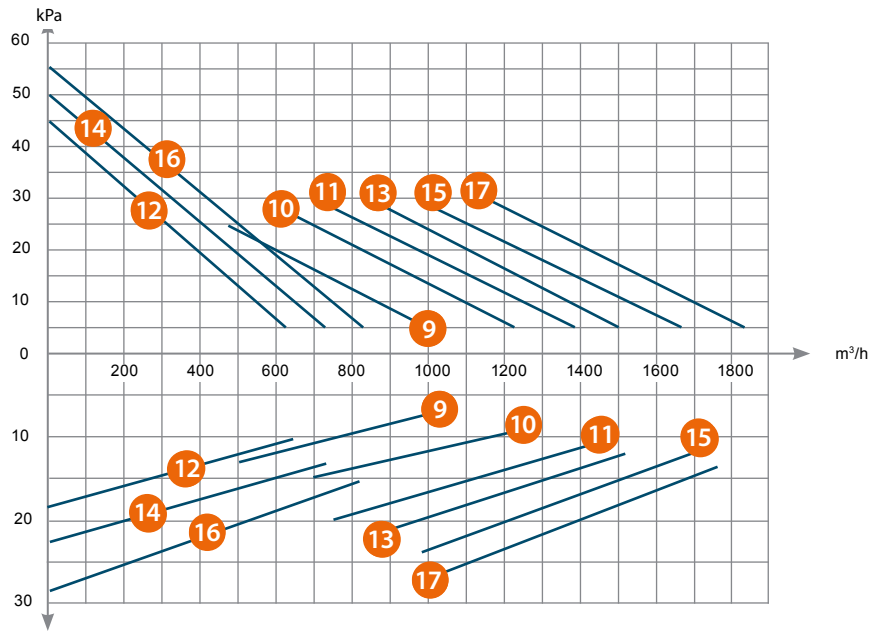
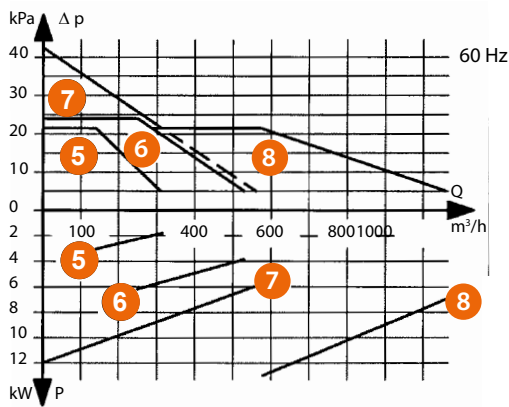
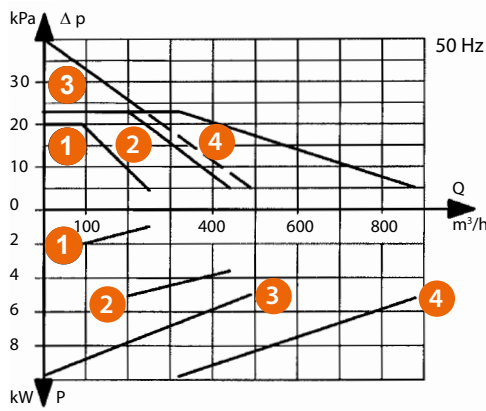

Turbopumps

- | | |
|---------------------|--------------------|
| 1. TLD 30 2.2 kW | 9. TPR 35 11 kW |
| 2. TED 30 5.5 kW | 10. TPR 40 15 kW |
| 3. TSD 30 9.2/11 kW | 11. TPR 43 18.5 kW |
| 4. TPD 30 11 kW | 12. TSR 43 18.5 kW |
| 5. TLD 36 4 Hp | 13. TPR 47 22 kW |
| 6. TED 36 10 Hp | 14. TSR 47 22 kW |
| 7. TSD 36 15 Hp | 15. TPR 50 30 kW |
| 8. TPD 36 15 Hp | 16. TSR 50 30 kW |
| | 17. TPR 53 37 kW |

Radial blowers Fume Extraction of fine dust from light material, ie: wood and paper

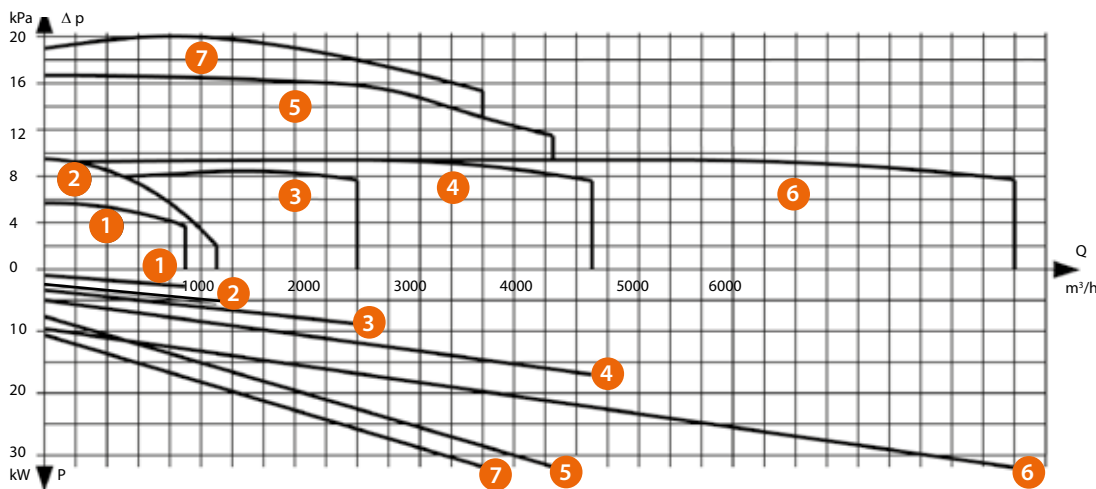

Radial blowers

1. RAF 500
2. RAF 500 S
3. RAF 1600
4. RAF 2500
5. RAF 2501
6. RAF 2502
7. RAF 2503

The capacity curves for Dustcontrol vacuum producers have been measured and are stated empirically. Outlet pressure losses from a normal outlet (silencer, back-flow valve/bend) have been accounted for in the curve. Additional equipment such as a diffuser can result in increased pressure loss and must be taken into consideration. Stated air-flows are for standard air (101.3 kPa@ 20° C).

The stated curves are for negative application, all pressures stated are assumed to be below relative atmospheric pressure at sea level. These devices can also be used for positive pressure application and will generate a greater pressure differential.

Turbopumps Direct driven

TLD/TED 30/36

3-phase

Turbopumps TLD 30/36 and TED 30/36 are direct driven single stage units. To ensure constant pressure and that cooling air is available to the pump when all outlets are closed, the tubing system should be equipped with a vacuum relief valve.

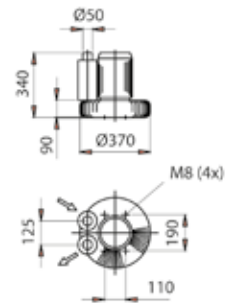
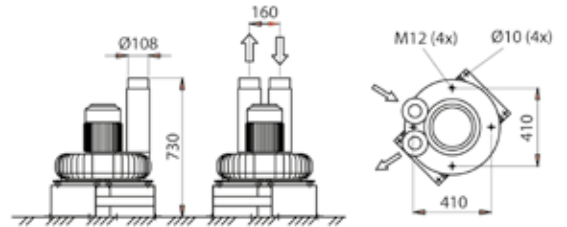

TPD 30/36

Turbopump TPD 30/36 is a direct driven twin impeller parallel series connected unit. To ensure constant pressure and that cooling air is available to the pump when all outlets are closed, the tubing system should be equipped with a vacuum relief valve.

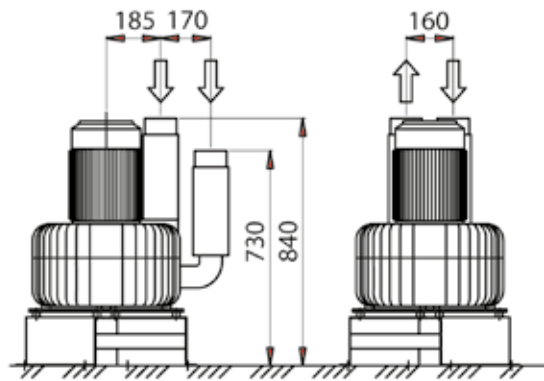

TSD 30/36

Turbopumps TSD 30/36 is a direct driven twin impeller series connected unit. This is used in demanding applications where high vacuum levels are required. To ensure that cooling air is available to the pump when all outlets are closed, the turbopump can be equipped with a cooling air inlet.

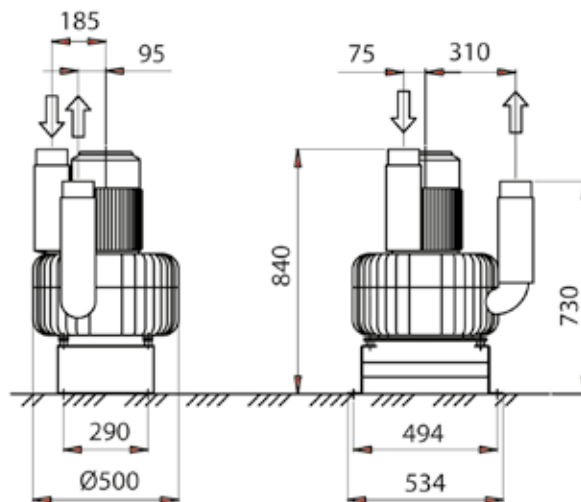

Turbopumps Direct driven

3-phase



Technical data

		TLD 30	TLD 36	TED 30	TED 36	TPD 30	TSD 30	TSD 36	TPD 36
Power supply	Hz	50	60	50	60	50	50	60	60
Pump	rpm	3000	3600	3000	3600	3000	3000	3600	3600
Weight	kg/lb	30 kg	66 lb	65 kg	143 lb	90 kg	90 kg	242 lb	242 lb
Max dP	kPa	20	22*	23*	24*	21*	40	43	20
Nominal Pressure	kPa	18	20	18	20	18	30	32	17
Max Q	m ³ /h/cfm	260 m ³ /h	176.6 cfm	450 m ³ /h	353 cfm	900 m ³ /h	450 m ³ /h	329.6 cfm	618 cfm
Sound Level of unit 1 m	dB(A)	75	75	75	75	75	75	75	75
Inlet/Outlet	Ø mm	50/50	2"/2"	108/108	4.25"/4.25"	108/108	108/108	4.25"/4.25"	4.25"/4.25"

*Standard DC Green System max 22 kPa



Model (Part No)

	TLD 30	TLD 36	TED 30	TED 36	TPD 30	TSD 30	TSD 36	TPD 36
Power	2.2 kW	4 hp	5.5 kW	10 hp	11 kW	11 kW	15 hp	15 hp
230/400V/50 Hz	4322							
230V/50 Hz			4326		4910	4907		
400V/50 Hz			4126		4911	4908		
460V/60 Hz		419006						
460V US/CAN/60 Hz				419306			479700	488100
600V CAN/60 Hz		419004		419101			4615	



Lubrication interval

	TLD 30	TLD 36	TED 30	TED 36	TPD 30	TSD 30	TSD 36	TPD 36
Power	2.2 kW	4 hp	5.5 kW	10 hp	9.2/11 kW	9.2/11 kW	15 hp	15 hp
Hours	10000 h	10000 h	10000 h	10000 h	1500 h	1500 h	1500 h	1500 h



Service Tip

These direct driven units are extremely reliable and have low service requirements. Always change the O-ring when repcsing the outboard bearing in the TSD and TPD pump. Also change the thermoprotector if there is one installed.

400 g Grease Cartridge for Dustcontrol Turbopumps, Part no 9928.



Turbopumps Direct driven



Accessories (Part No)

3037 Bracket 500 mm (2 req'd)
For wall installation of TLD 30/36.

3195 Silencer 80300/180
Used for silencing of 50 mm vacuum valve.

4477 Pump Chassis
For separate mounting of TED 30/36, TPD 30/36 and TSD 30/36.

4942 Silencer 100 300/200
Used for silencing of 76 mm vacuum valve and also exhaust silencing on 2.2–11 kW/4–15 hp turbopump. For accompanying tubing details, see installation example.

8253 Vacuum Relief Valve 50 mm
Used with TLD 30/36. The vacuum relief valve is installed on the tubing system (inlet side) on a branch tube. This delivers cooling air to the turbopump and can be adjusted for the desired vacuum level in the system.

8001 Vacuum Relief Valve 76 mm
Used with TED 30/36 and TPD 30/36. The vacuum relief valve is installed on the tubing system (inlet side) on a branch tube. This delivers cooling air to the turbopump and can be adjusted for the desired vacuum level in the system.

40595 Cooling air inlet with silencer for TSD 30/36
Cooling air is introduced to the turbopump between stages so the unit can be driven with all outlets closed without the risk of overheating.

42297 Back Flow Valve Ø108
Installed on the inlet side of the turbopump when two or more units are parallel installed.

Silencing Covers. The silencing covers will reduce the sound level by 4 dB.

- 4659 Intermediate piece Ø108**
- 40261 Silencing Cover for TED 30 2,5 kW**
- 40697 Silencing Cover for TED 30 5.5 kW**
- 40698 Silencing Cover for TED 30 9.2 kW**
- 42988 Silencing Cover for TLD 30 2.5 kW**

Installation Example, Silencers

TLD 30/36

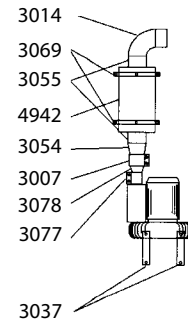

TED 30/36
TSD 30/36

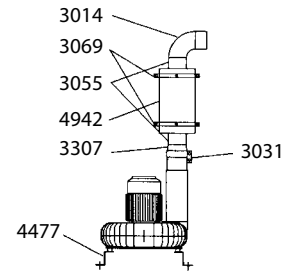

TPD 30/36

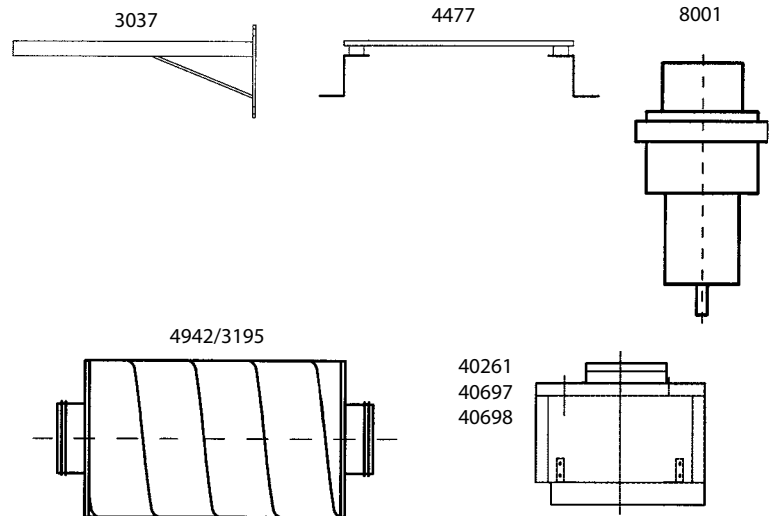
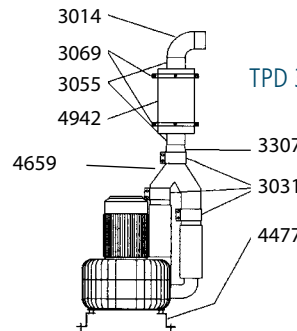

Turbopumps Belt driven

TPR

Turbopumps with TPR designation are parallel connected twin impeller belt driven units. Cooling air is introduced into the unit through an adjustable vacuum relief valve. The vacuum pressure in the system can be held constant when different outlets are opened. The turbopumps are equipped with thermal overload protection on the outboard bearing which will trip out when bearing temperature becomes excessive. A back flow valve is built into the unit on the inlet side.



TSR

Turbopumps with TSR designation are series connected two stage belt driven units. Cooling air is introduced into the pump through a slot between the two stages.

In this way the second stage cools the first stage indirectly, allowing the pump to run at extremely high vacuum and low airflow without overheating. The turbopumps are equipped with thermal overload protection on the outboard bearing which will trip out when bearing temperature becomes excessive.

A back flow valve must be additionally installed on the inlet side of the unit when several units are to be installed in parallel.



Turbopumps Belt driven



Technical data

	TPR 35	TPR 40	TPR 43	TSR 43	TRP 47	TSR 47/48	TPR 50	TSR 50/52	TPR 53
Pump (rpm)	3500	4000	4300	4300	4700	4700	5000	5000	5300
Weight (kg)	400	400	430	430	450	450	530	530	530
Max dP (kPa)	22	26*	28*	46	29*	50	30*	54	30*
Nominal Pressure (kPa)	20	20	20	35	21	37	23	40	23
Max Q (m ³ /h)	1000	1200	1400	650	1500	700	1650	800	1800
Sound Level of unit 1 (dBa)	66	66	66	66	66	66	66	66	66
Inlet/Outlet (Ø mm)	160/160	160/160	160/160	108/108	160/160	108/108	160/160	108/108	160/160

*Standard DC Green System Max 22 kPa.



Power consumption

	TPR 35	TPR 40	TPR 43	TSR 43	TRP 47	TSR 47/48	TPR 50	TSR 50/52	TPR 53
	Part No/kW(hp)								
230V (50Hz)		106802/15 kW	107202/18.5 kW	107252/18.5 kW	107702/22 kW	107752/22 kW	109202/30 kW	109252/30 kW	109302/37 kW
400V (50Hz)	106600/11kW	106800/15 kW	107200/18.5 kW	107250/18.5 kW	107700/22 kW	107750/22 kW	109200/30 kW	109250/30 kW	109300/37 kW
460V USA/CAN (60Hz)		106805/20 hp	107207/25 hp	107257/25 hp	107707/30 hp	107757/30 hp	109207/40 hp	109257/40 hp	109307/50 hp
600V CAN (60Hz)		106806/20 hp	107206/25 hp	107256/25 hp	107706/30 hp	107756/30 hp	109206/40 hp	109256/40 hp	109306/50 hp



Lubrication interval

	TPR 35	TPR 40	TPR 43	TSR 43	TRP 47	TSR 47/48	TPR 50/53	TSR 50/52
	Δ p							
22 kPa	1500 h	1500 h	1500 h	-	1500 h	-	1500 h	-
25 kPa	750 h	750 h	1500 h	-	1500 h	-	1500 h	-
28 kPa	-	-	1000 h	-	1000 h	-	1000 h	-
30 kPa	-	-	-	1500 h	-	1500 h	750 h	1500 h
40 kPa	-	-	-	1000 h	-	1000 h	-	1000 h



Accessories (Part No)

9928 400 g Grease Cartridge for Dustcontrol Turbopumps

Turbopumps Belt driven

+ Accessories (Part No)

Silencer

Part No	Conn	Dimensions
3182	Ø160	L=1200, Ø355
3183	Ø160	L=600, Ø355
3184	Ø160	L=600, Ø260

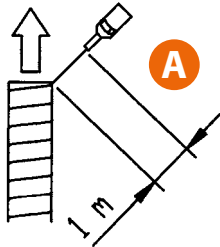
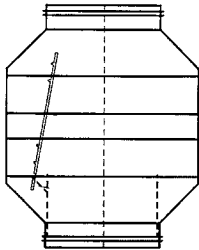
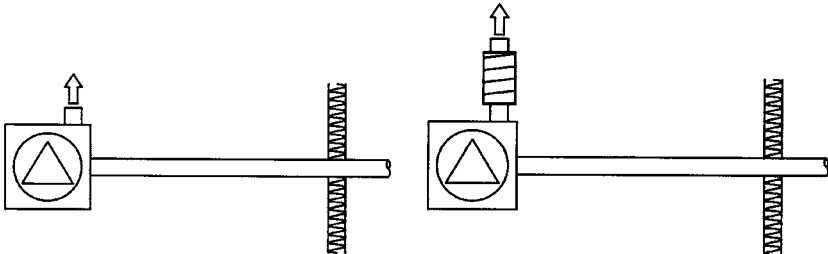

Part No	A
-	75 dB(A)
3184	64 dB(A)
3182	62 dB(A)

8051 Back Flow Valve 160 mm

Installed on the inlet side of the TSR or TPR when two or more units are parallel installed.

Dimensions, Installation Example

TPR

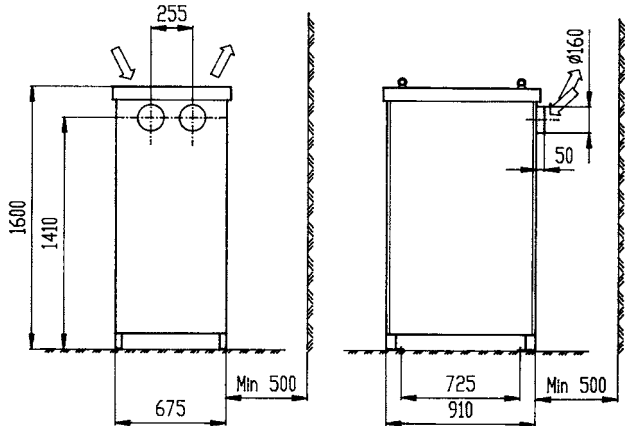

TSR

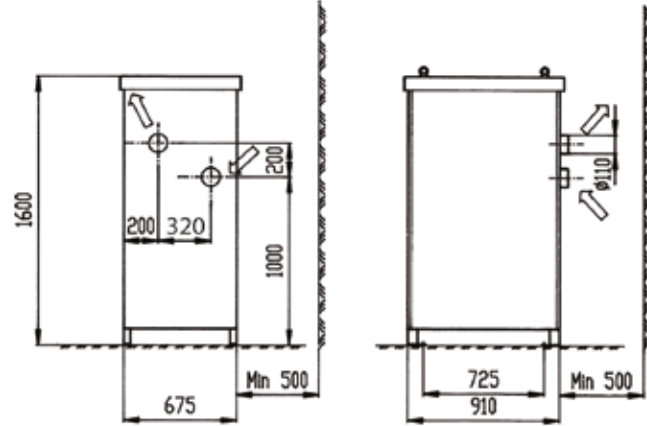

Radial blowers

RAF 500

RAF 500S

3-phase

The RAF 500 is ideal for small fume extraction systems, for example with Flexpipes. Spiral tubing is generally used. The blower is a direct driven unit with minimal service requirements. (Lubrication interval 10000 hours.)

The RAF 500S is for application in extraction systems with lighter dust, e.g: wood dust. It is a twin wheel, series connected unit. The unit is direct drive and has minimal service requirements. (Lubrication interval 10000 hours.)

RAF 500 (Part No)

Without Silencing Enclosure:

111900 2.2 kW 220–240/380–420 V/ 50 Hz
111904 4 hp 460 V/60 Hz USA/CAN
111906 4 hp 600 V/60 Hz CAN

With Silencing Enclosure:

111910 2.2 kW, 220–240/380–420 V/50 Hz
111916 4 hp 460 V/60 Hz USA/CAN

RAF 500S (Part No)

Without Silencing Enclosure:

111800 5.5 kW 220–240/380–420 V/ 50 Hz
111804 10 hp 460 V/60 Hz USA/CAN

With Silencing Enclosure:

111810 5.5 kW, 220–240/380–420 V/50 Hz
111816 10 hp 460 V/60 Hz USA/CAN



Shutter valve auto



Technical data

		RAF 500	RAF 500S
Motor	kW	2.2 kW/4 hp	5.5 kW/10 hp
Pump	rpm	3000	3000
Weight	kg	39	150
Max dp	kPa	5.6	9.5
Max Q	m ³ /h	900	1100
Sound Level*			
- without silencing enclosure	dB(A)	79	79
- with silencing enclosure	dB(A)	66	66
Inlet/Outlet	mm	108/76	108/100

*) with exhaust silencer, 1 m



Accessories RAF 500 and RAF 500S (Part No)

4476 Silencer 100, 600/200 mm. Used for silencing exhaust and inlet.
42297 Back Flow Valve 108 mm. Installed on the inlet side of the fan when two or more units are parallel installed. A closed shutter valve on the inlet at start-up decreases the power surge.
808404 Shutter valve auto 108 mm
8088 Solenoid valve 24 V AC
8026 Solenoid valve 24 V DC

The target efficiencies for Dustcontrol's RAF-fans

The target efficiencies for Dustcontrol's RAF-fans when measuring the pressure differential over the fan with a duct fitted at the inlet and a free outlet.

RAF	η_e (%)
500	41,7
500s	48,0
1600	47,4
2500	49,0
2501	46,5
2502	44,8
2503	47,2

Radial blowers

Dimensions RAF 500/ RAF 500S with Silencing Enclosure

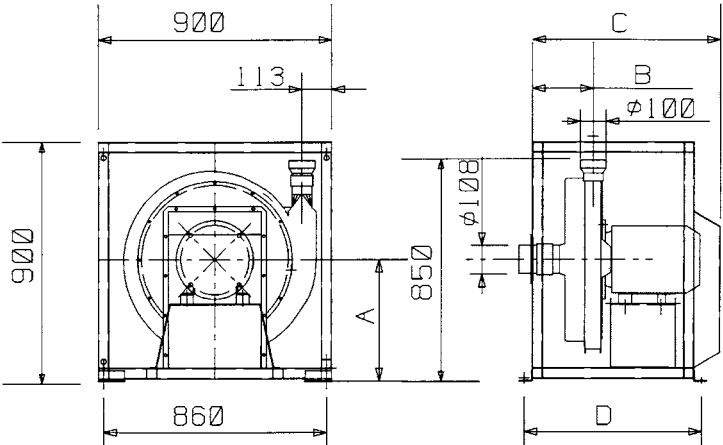

RAF 500

	A	B	C	D
RAF 500	450	157	550	510
RAF 500S	460	325	725	685

Dimensions RAF 500 without Silencing Enclosure

Wall installation

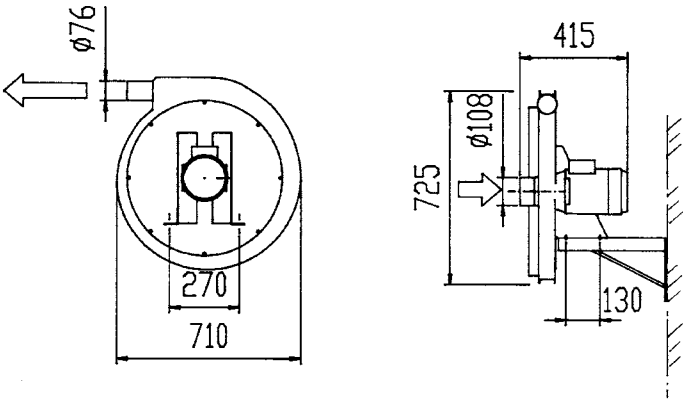

Floor installation

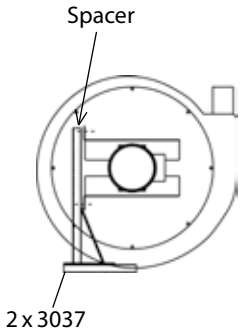

RAF 500S



Radial blowers

RAF 1600/2500

RAF 1600/2500 are single stage direct driven radial blowers for less demanding pressure applications such as fume extraction. The blowers are equipped with vibration isolators and silenced enclosure. They should always be equipped with an exhaust silencer. These units have minimal service requirements (lubrication interval 10000 hours).



Technical data

		RAF 1600		RAF 2500	
		50 Hz	60 Hz	50 Hz	60 Hz
Pump	rpm	3000	3600	3000	3600
Weight ca	kg	290	290	330	3300
Max dp	kPa	7.7	7.7	9.3	9.3
Max Q	m³/h	2000	2000	3500	3500
Sound Level*	dB(A)	68	68	70	70
Inlet/Outlet	mm	200/160	200/160	200/160	200/160

* with exhaust silencer, 1 m



Power consumption

		RAF 1600		RAF 2500	
		Hz			
400V	50	112000	7.5 kW	112100	15 kW
230V	50	112002	7.5 kW	112102	15 kW
460V USA/CAN	60	112007	10 hp	112107	20 hp
600V CAN	60	112006	10 hp	112106	20 hp



Accessories (Part No)

8051 Back Flow Valve 160 mm.
Installed on the inlet side of the fan when two or more units are parallel installed.

A closed shutter valve on the inlet at start-up decreases the power surge.

- 807500** Shutter valve auto 200 mm
- 8088** Solenoid valve 24 VAC
- 8026** Solenoid valve 24 VDC

Dimensions, Installation Example

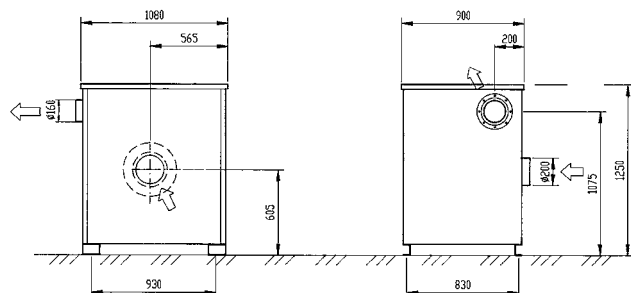

Radial blowers

RAF 2501

The RAF 2501 is applied in extraction systems requiring large air-flows for lighter types of dust and cleaning. Pressure generation is achieved through two series connected stages. The unit is equipped with vibration isolation and a silenced enclosure. The unit should always be equipped with an exhaust silencer.

The unit is direct driven and has minimal service requirements (lubrication interval 10000 hours).

V	Hz	Motor	Part No
400	50	30 kW	112200
230	50	30 kW	112202
460 USA/CAN	60	40 hp	112204
600 CAN	60	40 hp	112206

RAF 2502

The RAF 2502 is applied in extraction systems requiring large air-flows such as systems for fume extraction. RAF 2502 work with two parallel impellers. The unit is equipped with vibration isolation and a silenced enclosure. The unit should always be equipped with an exhaust silencer.

The unit is direct driven and has minimal service requirements (lubrication interval 10000 hours).

V	Hz	Motor	Part No
400	50	30 kW	112300
230	50	30 kW	112302
460 USA/CAN	60	40 hp	112304
600 CAN	60	40 hp	112306

RAF 2503

Pressure generation is achieved through two series connected stages. The unit is equipped with vibration isolation and a silenced enclosure. The unit should always be equipped with an exhaust silencer. The unit is direct driven and has minimal service requirements (lubrication interval 10000 hours).

RAF 2503 develops a maximum negative pressure of 20 kPa. Note though that the maximum airflow is 2800 m³/h. Above this, the power consumption would be too large for the 30 kW motor, so the design of the system must throttle to this level for all cases.

V	Hz	Motor	Part No
400	50	30 kW	112400



Technical data

		RAF 2501		RAF 2502		RAF 2503
		50 Hz	60 Hz	50 Hz	60 Hz	50 Hz
Pump	rpm	3000	3600	3000	3600	3000
Weight ca	kg	440	440	430	430	450
Max dp	kPa	17	17	9.4	9.4	20
Max Q	m ³ /h	3300	3300	6200	6200	2800
Sound Level*	dB(A)	74	74	74	74	74
Inlet/Outlet	mm	200/160	200/160	2x200/2x160	2x200/2x160	200/160

*) with exhaust silencer, 1 m



Accessories (Part No)

8051 Back Flow Valve 160 mm.
Installed on the inlet side of the fan when two or more units are parallel installed.

A closed shutter valve on the inlet at start-up decreases the power surge.

807500 Shutter valve auto 200 mm *
8088 Solenoid valve 24 V AC

* **Note:** Shutter valve Ø 200/Ø 250 only for single step fans (10 kPa).

Dimensions RAF 2501 / RAF 2503

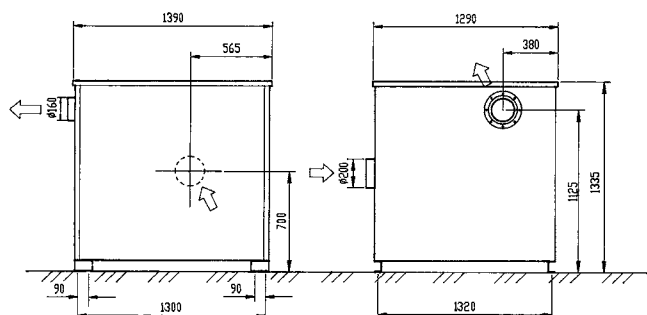

Dimensions RAF 2502

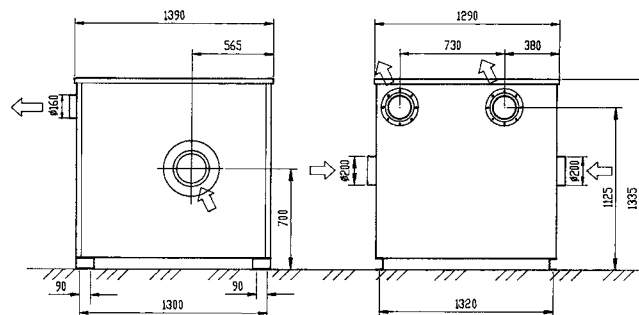

Measuring Tube

Dustcontrol's measuring tube is an easy and fast tool for the service engineer to carry out a control measurement – before and after installing the central vacuum system. The tube measures the air flow Q (m^3/h) when the system is open, leakage flow and negative pressure when the system is closed. The measuring tube is placed between the filter and the vacuum producers, see graphic.

The measuring tube is included as a standard part in central vacuum systems from Dustcontrol's and can also be added to existing systems. Air flow meter is not included.

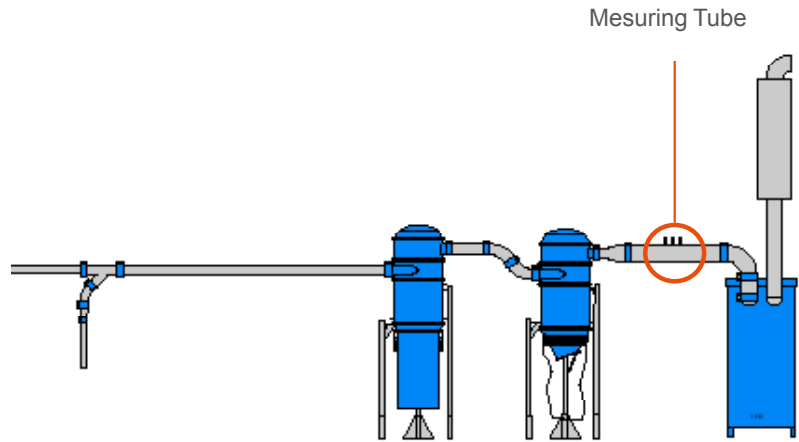

+ Accessories (Part No)

- 3365** Measuring Tube Ø 200
- 3366** Measuring Tube Ø 160
- 3367** Measuring Tube Ø 108
- 3372** Measuring Tube Ø 76
- 3371** Measuring Tube Ø 50

Fan Silencers for RAF 1600/2503

In order to decrease the noise level of our fans, RAF 1600 and RAF 2503, an in-line silencer must be installed on the exhaust duct. But you can fit one to the inlet as well, if required.

Several examples are illustrated of how noise level measurements can be affected. It is not unusual to obtain measurements of up to 110–120 dB(A) in completely non-silenced installations.

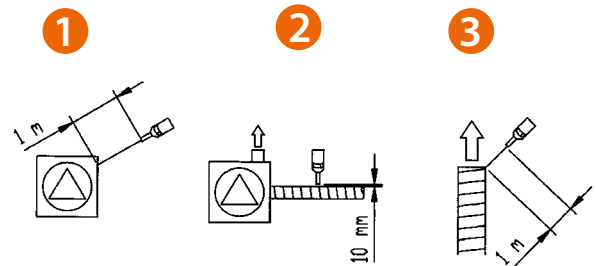

	1	2	3
	96	100	102
Silencer Ø 160 x 600 x 260 (Prod no 3184)			
	75	78	81
Silencer Ø 160 x 1200 x 260 (Prod no 3182)			
	68	72	71

+ Accessories Fan silencers (Part No)

- | Part No | Conn | Dimensions |
|-------------|------|--------------|
| 3182 | Ø160 | L=1200, Ø355 |
| 3183 | Ø160 | L=600, Ø355 |
| 3184 | Ø160 | L=600, Ø260 |

Dimensions, Installation Example

TPR 35–TPR 50, S 32000–S 34000, F 20000

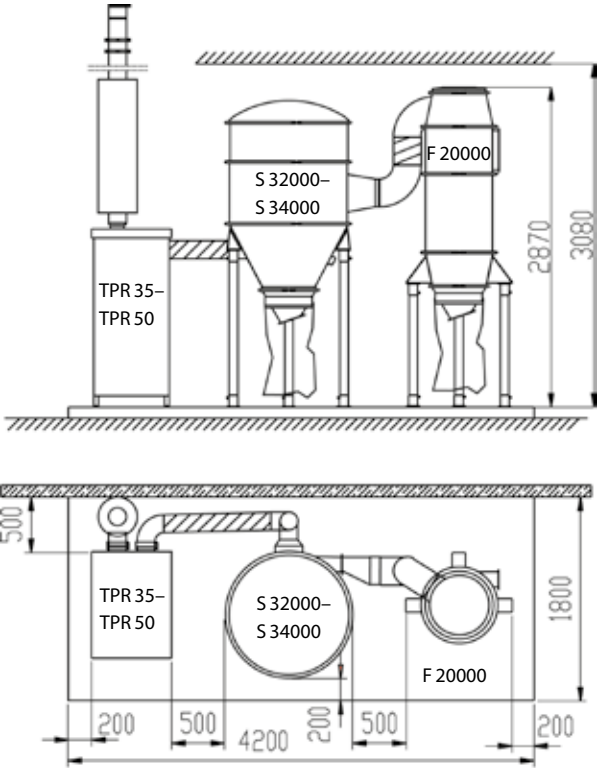

S 34000, RAF 2500

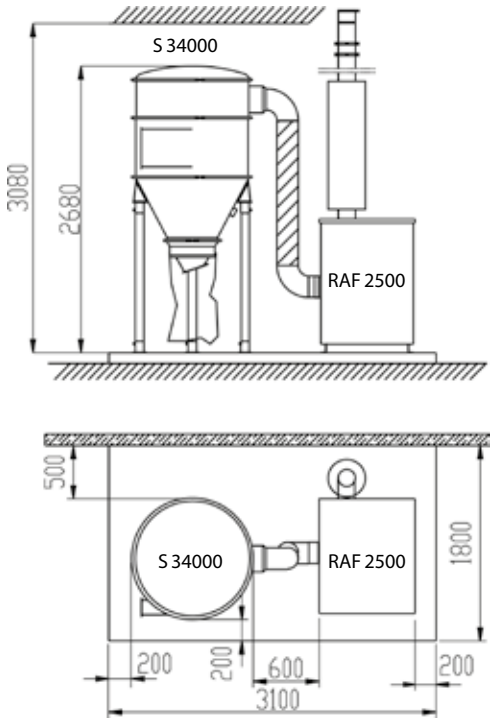

RAF 2501 / 2503, S 34000

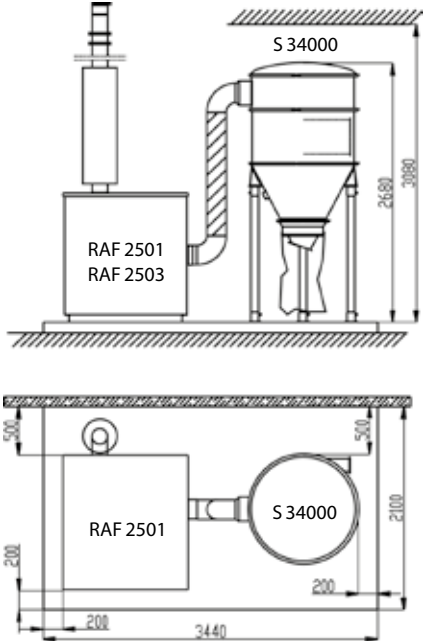

RAF 2502, S 34000X

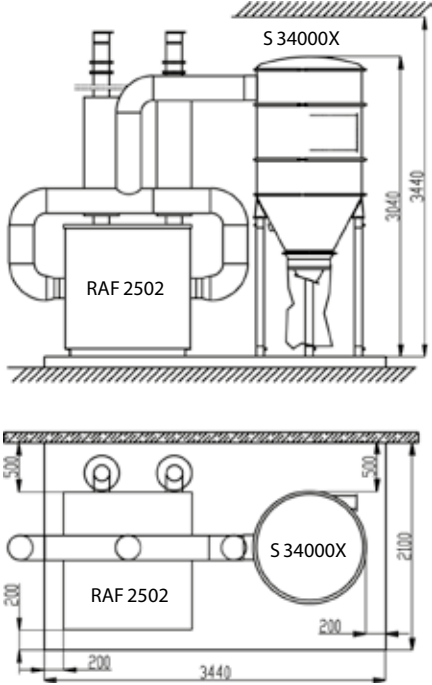



Filter Units

An extraction system should always be equipped with a filter unit. The filter unit separates coarse material in the cyclone body of the unit and fine dust in an internal arrangement of conical pleated cartridge filters.

About Dustcontrol Filter Units

An extraction system should always be equipped with a filter unit. The filter unit separates coarse material in the cyclone body of the unit and fine dust in an internal arrangement of conical pleated cartridge filters. Pleated filters have very high filter areas in relation to their physical size. The filter units therefore have high capacity while maintaining compact overall dimensions.

Filters are cleaned with reverse pulse which results in very effective cleaning, long filter life and low maintenance.

Normally the filter units are equipped with a plastic bag or container for collection of the extracted material, but other types of discharge arrangements can also be installed.

General

In the filter unit, dust is separated from the air in several steps:

- the cyclone will separate particles down to a size of 1/100 mm.
- the filter will separate particles which go through the cyclone.

The dust laden air is introduced into the cyclone at a high velocity. Through centrifugal force the dust particles, with higher relative mass than the air molecules, are forced outward toward the wall of the cyclone and fall toward the bottom. The air flows toward the centre of the cyclone and through the filter.

Filter Loading

Permissible air flow determines the air velocity through the filter material, known as filter loading. Consider also inlet/outlet velocities. Permissible filter loading varies with dust type.



Dust type

Permissible filter loading
(m³/h)/m²

Stone	120
Concrete	120
Wood	160
Cement	120
Plastic	120
Graphite	60
Carbon black	60
Welding fume	60
Fibreglass	60



Example

For the extraction of welding fume, the maximum permissible flow in the S 34000 will be:

$$60 \text{ (m}^3\text{/h)/m}^2 \times 34 \text{ m}^2 \text{ filter area} = 2040 \text{ m}^3\text{/h}$$

The velocity of the air through the inlet and outlet should not exceed 30 m/s. When one filter unit does not have sufficient capacity, several units can be connected in parallel.



Tip

For smaller systems, the filter unit and vacuum producer can be delivered unitized on a common chassis.



Filter Units



Choose the right filter unit

Dust type	Air Flow m ³ /h	Select filter unit
Stone, concrete, cement, wood, plastic, metal	≤ 1000*	S 11000
	1000-1500	S 21000
	1000-2000*	S 32000/2 x S 11000
	2000-4000*	S 34000
	4000-5000*	S 34000X
	≤ 8000	S 46000
Graphite, carbon black, welding fume, fibre glass	≤ 700	S 11000X
	700-1400	2 x S 11000X
	700-2000	S 34000
	2000-2900	S 34000X
	≤ 5500	S 46000
ATEX	≤ 1000*	S 11000 EX**
	1000-1500	S 21000 EX**
	2000-4000*	S 34000 EX**

*) In applications with a large percentage of finer particulate, the above values should be reduced 20 %.

***) Kst ≤ 200 bar/m/s



Central Units

Air flow*	Vacuum level required	Select unit
≤ 200 m ³ /h	normal	DC 3800 Stationary
200-400 m ³ /h	normal	DC 11-Module 5.5/7.5 kW
200-400 m ³ /h	large	DC 11-Module 11 kW S

*) always consider dust type and filter loading as above

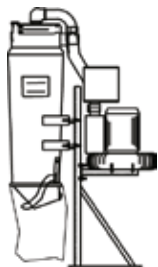

DC 3800
Stationary

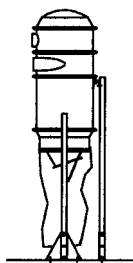

S 11000
S 11000X

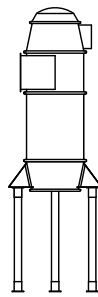

S 21000

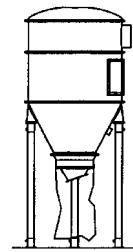

S 32000
S 34000
S 34000X

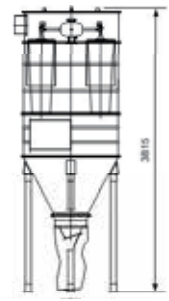

S 46000



Tip For smaller systems, the filter unit and vacuum producer can be delivered unitized on a common chassis.

Filter Units

S 11000, S 11000X

The S 11000 filter unit is of modular construction and is therefore flexible in application. The inlet module can for example, be both rotated and reversed.

Additional module rings can be installed to increase the storage capacity of the cyclone. The S 11000 is either floor or wall mounted. The S 11000 and S 11000X must always be equipped with a discharge cone or other discharge arrangement.

The X model is equipped with larger filter area and an extra module ring.



Accessories S 11000 and S 11000X (Part No)

- 4030** S 11000 HEPA-Module, post-assembly
- 40407** Module Ring
- 40655** Discharge Cone for container
- 40656** Steel Container, 40 l
- 42111** Collection Bag, 50 pcs, antistatic
- 42807** HEPA filter 3,7 m³
- 44077** Longopac Midi (1x25 m)
- 44078** Longopac Holder Midi
- 44079** Discharge Cone Longopac Midi
- 4706** Discharge Cone
- 4714** Collection Bag, 50 pcs
- 5024** Wall Bracket Complete
- 7179** Stand Complete

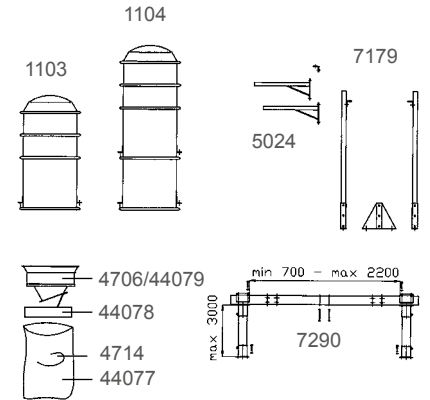

7290 Widening Chassis
Used in applications where the separator is to discharge into a larger container such as a tipping container.

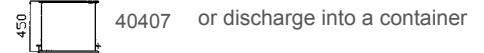

8188 Timer
Can be used to activate filter cleaning.

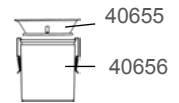

Part No	Description
1103	S 11000 AC
110302	S 11000 AC stainless steel
110300	S 11000 DC
1104	S 11000X AC
110400	S 11000X DC

Dimensions, arrangements

S 11000

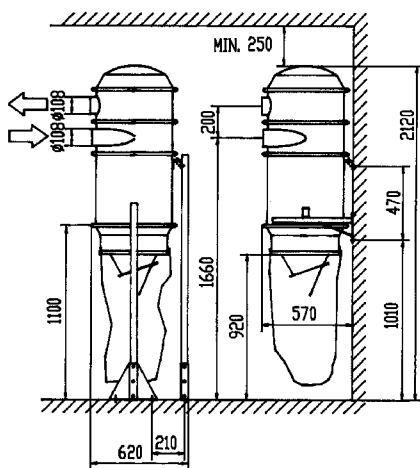

S 11000

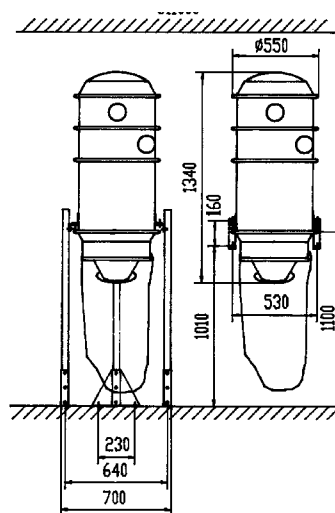

S 11000X

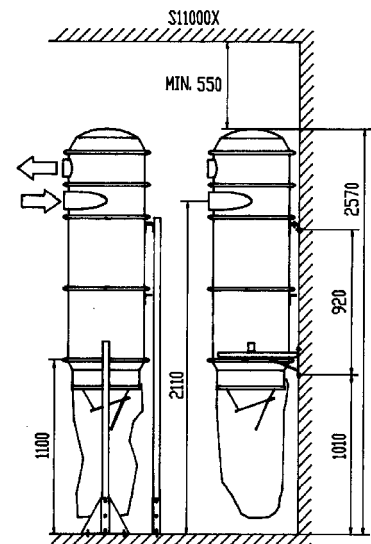

Filter Units

S 11000, S 11000X with HEPA-Module

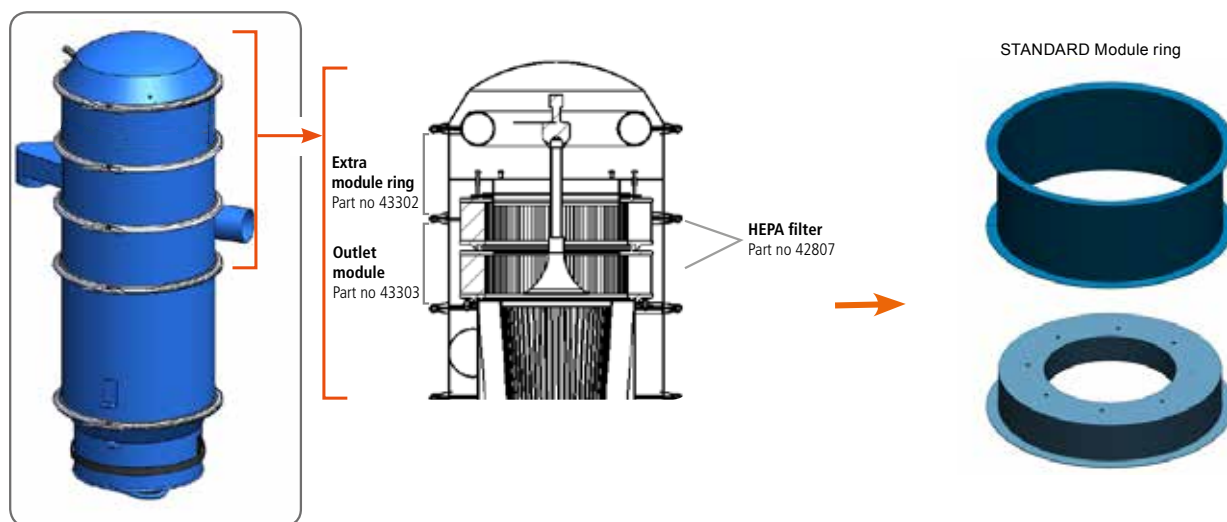

S11000 filter units, DC 11000 dust extractors and DC 11-modules may be combined or completed with Dustcontrol's HEPA-Module. It fulfills the HEPA H13 specifications and is excellent for cleaning air. The module is specially suited to capture the smallest and most dangerous particles. It also works as an extra protection for the pump and motor.

The HEPA-Module complete (part no 4030) consists of two HEPA-filters (part no 42807), an outlet module (part no 43303) and an extra module ring (part no 43302) with a welded inner part to keep the filters in place. The HEPA-Module will be delivered with all necessary parts such as gaskets and joints for quick and easy mounting to the existing product.

+ Accessories S 11000 and S 11000X (Part No)

4030 S 11000 HEPA-Module, post-assembly

Part No	Description
4030	HEPA-Module complete*
11034	S11000 HEPA AC
110304	S11000 HEPA DC
11044	S11000X HEPA AC
110404	S11000X HEPA DC

* For post-assembly

4030 HEPA-Module Complete for Post-Assembly

- Easy to mount on top of an existing S11000, DC 11-Module or DC11000, see owners manual
- Just 200 mm extra height on the existing cyclone
- Fits on older and new cyclones
- Copes with high pressure and high air flow (max Q= 1000 m³/h, max dp= 40 kPa)
- Easy filter change



Filter Units

S 21000, S 32000, S 34000, S 34000X, S 46000

The S 21000 and S 34000 are constructed of modules and are therefore very flexible. The inlet modules can for example be both rotated and reversed. Additional module rings can be installed to give increased storage capacity of collected material. The X model is equipped with a larger filter area and an extra module ring.

The S 21000, S 32000, S 34000, S 34000X and S 46000 are installed on legs. As standard, extracted material is collected in a plastic bag, alternative discharge options can be selected.

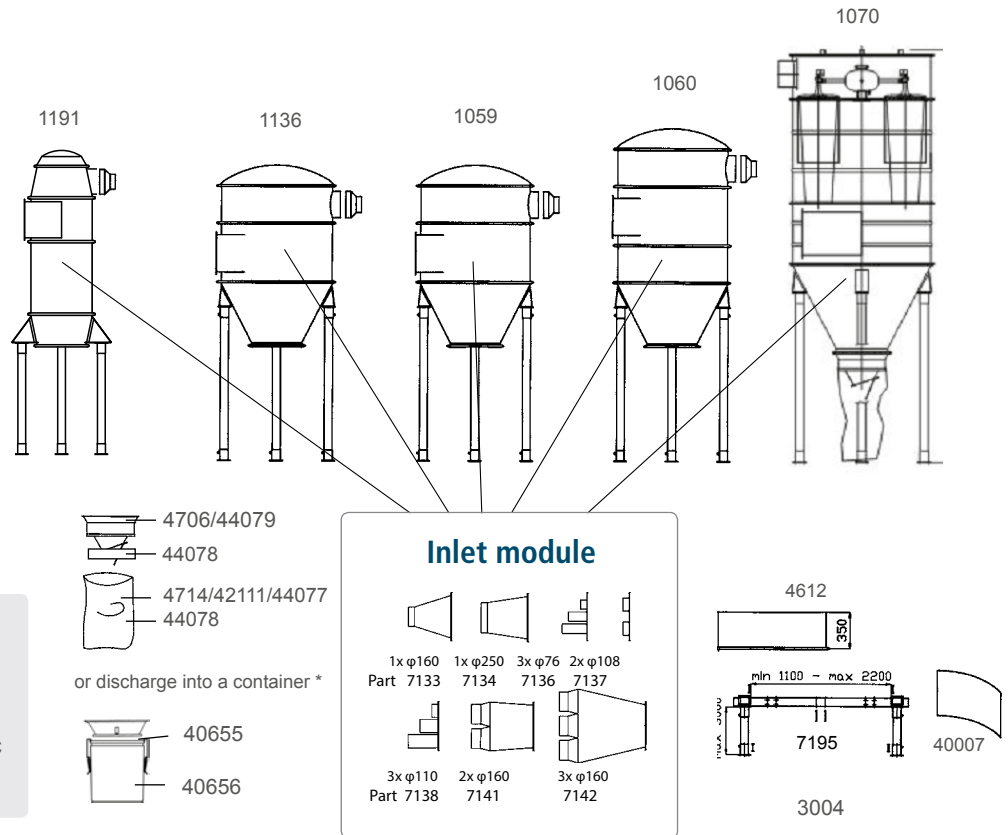

Part No	Description	Part No	Description
1191	S 21000 AC	119100	S 21000 DC
1136	S 32000 AC	113600	S 32000 DC
1059	S 34000 AC	105900	S 34000 DC
1060	S 34000X AC	106000	S 34000X DC
1070	S 46000 AC	107000	S 46000 DC

* Other options available, see Pre-Separator chapter



Technical data

	S 11000	S 11000X	S 21000	S 32000	S 34000	S 34000X	S 46000
Inlet mm	Ø 108	Ø 108	optional	optional	optional	optional	optional
Outlet mm	Ø 108	Ø 108	Ø 250	Ø 250	Ø 250	Ø 250	Ø 250 x 2
Max Q	1000 m³/h*	1000 m³/h*	1500 m³/h*	2000 m³/h*	4000 m³/h*	5000 m³/h)	8600 m³/h*
Filters: Pleated polyester cartridge							
Part no x pcs	4292 x 1	4284 x 1	4284 x 1	4292 x 2	4292 x 4	4284 x 4	4284 x 6
Total filter area	8.4 m²	12 m²	12 m²	16.8 m²	34 m²	48 m²	72 m²
Degree of separation	> 99.9 %	> 99.9 %	> 99.9 %	> 99.9%	> 99.9 %	> 99.9 %	> 99.9 %
Class according to EN 60335	M	M	M	M	M	M	M
Max temperature, filter	130°C	130°C	130°C	130°C	130°C	130°C	130°C
Filter cleaning with Reverse Pulse							
Compressed air	4 l/s, 4 bar	4 l/s, 4 bar	4 l/s, 4 bar	4 l/s, 4 bar	4 l/s, 4 bar	4 l/s, 4 bar	4 l/s, 4 bar
Connection, hose	6/8 mm	6/8 mm	6/8 mm	6/8 mm	6/8 mm	6/8 mm	6/8 mm
EI connection	24V AC alt. DC, 12 W	24V AC alt. DC, 12 W	24V AC alt. DC, 12 W	24V AC alt. DC, 12 W	24V AC alt. DC, 12 W	24V AC alt. DC, 12 W	24V AC alt. DC, 12 W
Max P (kPa)	40 kPa	40 kPa	40 kPa	40 kPa	40 kPa	40 kPa	20 kPa

*Note: Always consider filter loading.

Accessories on the following page

Filter Units

S 21000, S 32000, S 34000, S 34000X, S 46000



Accessories (Part No)

3004 Steel Tube 76 mm, galvanized
Delivered in 3 m lengths. Used for longer legs when required (standard leg L=1400 mm)

40007 Inlet Wear Plate S 32/34000
Inlet wear plate for minimising wall wear on the cyclone when collecting abrasive material.

42111 Collection Bag, 50 pcs, antistatic

40655 Discharge Cone for container

40656 Steel Container

44077 Longopac Midi (1x25 m)

44078 Discharge Cone

44079 Discharge Cone Longopac Midi

4612 Module Ring, complete S 32/34000. Increases the height of the cyclone by 0.35 m and volume by ca 0.3 m³.

4706 Discharge Cone for bag

4714 Collection Bag, 50 pcs

7133 Inlet D = 160x1

7134 Inlet D = 250x1

7136 Inlet D = 76x3

7137 Inlet D = 110x2

7138 Inlet D = 110x3

7141 Inlet D = 160x

7142 Inlet D = 160x3

7195 Widening Chassis
Used when collected material is to be deposited in a container up to 1,1 m³. Increases width between the legs from 860 mm to 1460 mm. "With legs > 3000 mm a widening chassis should be ordered."

819001 Sequence Control S 32/34000.
Can be used to activate filter cleaning.

Dimensions, arrangements

S 21000

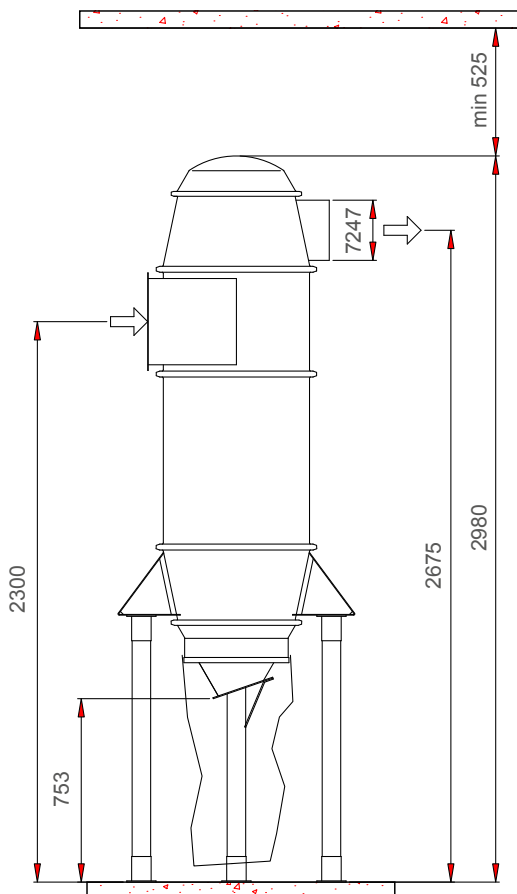

S 32000
S 34000

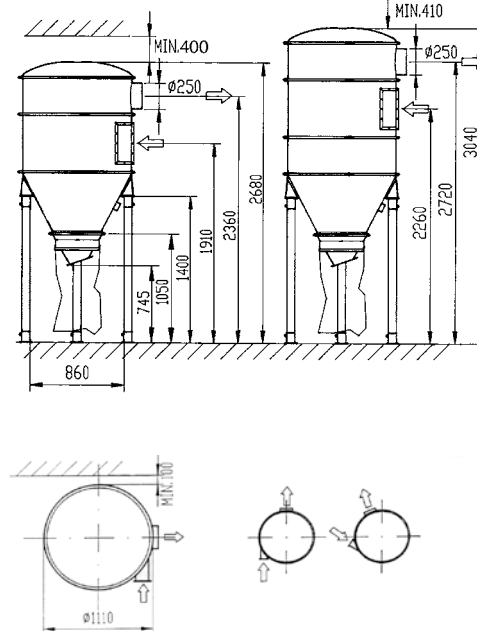

S 34000X

S 46000

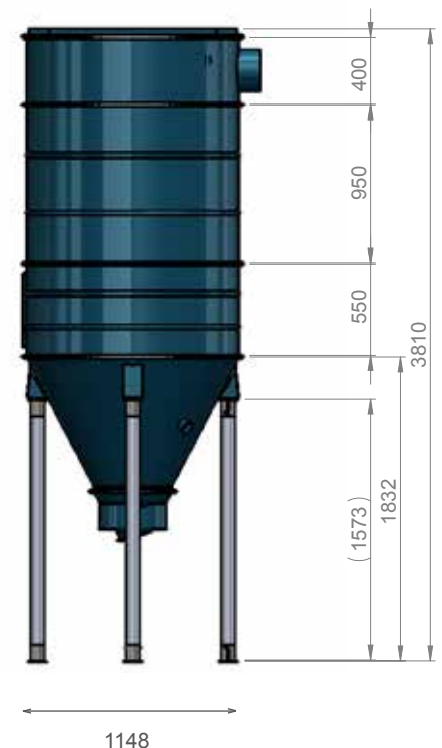

Filter Units

S 11000 EX, S 21000 EX, S 34000 EX



Dustcontrol has been operating in the field of environmental equipment for more than 40 years and has extensive experience in equipment and systems for potentially explosive dust.

Keeping the work environment clean and safe minimises the risk of explosion, maximises your production up-time, increases your products' quality and gives significant cost savings.

S 11000 / S 21000 / S 34000 EX are the new generation high vacuum dust collectors for potentially combustible dust. The units comply with the ATEX directive.

S 11000 / S 21000 / S 34000 EX have been created in order to meet various extraction requirements and to meet the challenges and rapid changes presented to modern industry. The systems are all marked with the EX symbol and are category 3D equipment according to directive 2014/34/EU. This means that models with the EX symbol may be placed in areas classified as zone 22 according to directive 1999/92/EC.

S 11000 EX

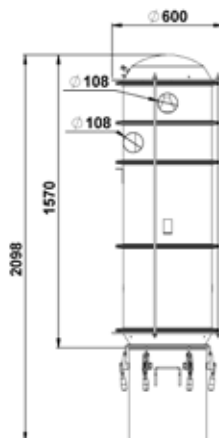

S 21000 EX

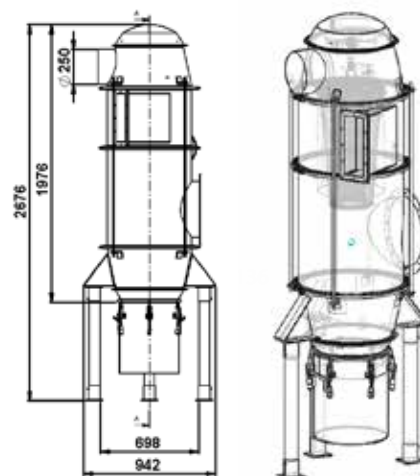

S 34000 EX

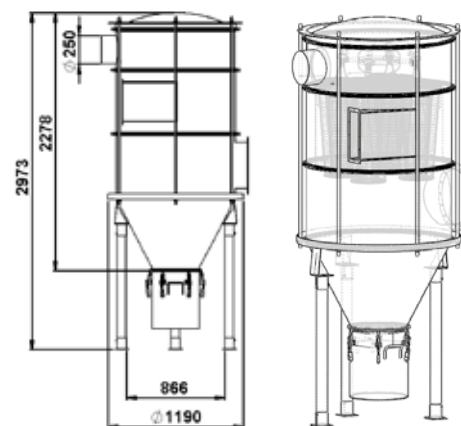

Part No	Description
110301	S 11000 EX
119201	S 21000 EX
105901	S 34000 EX



Technical data

	S 11000 EX	S 21000 EX	S 34000 EX
Inlet mm	Ø 108	optional	optional
Outlet mm	Ø 108	Ø 250	Ø 250
Max Q	1000 m ³ /h	1500 m ³ /h	4000 m ³ /h
Soiled side air volume	251 l	464 l	1312 l
Filters: Pleated Polyester Cartr (Part No and pcs)	429206 x 1	429206 x 1	429206 x 4
Total Filter Area	8.4 m ²	8.4 m ²	34 m ²
Degree of separation EN 60335	> 99.9 %	> 99.9 %	> 99.9 %
Container	60 l	60 l	60 l
Max temp filter	130°C	130°C	130°C
Filter cleaning with Reverse Pulse			
Compressed air	4 l/s, 4 bar	4 l/s, 4 bar	4 l/s, 4 bar
Connection, hose	6/8 mm	6/8 mm	6/8 mm
El connection	24 V DC, 12 W	24 V DC, 12 W	24 V DC, 12 W



Filter Units

DC HEPA box

Within the BioPharma, food processing, electronic, car and aerospace industries (just to name a few) there are numerous environments which need extreme safeguards against dispersion of particles and aerosols. Here the DC HEPA box enters the arena as a additional filter with a highest filtration level (>0.15 micro meter).

The DC HEPA box has a robust design and withholds high negative pressure (40 kPa) which differentiates it from competing products.

The DC HEPA box is even recommended for use as a “police filter” between the filter unit and the vacuum producer in an ATEX environment.

If for any reason the filter unit fails, the DC HEPA box stops the dust from reaching the radial blower or turbo pump. In this way all standard vacuum producers can be used for ATEX applications, provided that the vacuum producer is placed outside an ATEX zone.



Contamination free filter change

Part No	Description
1180	DC HEPA box

+ Accessories (Part No)

42111	Plastic Bag ESD
42896-1	Hepa Filter

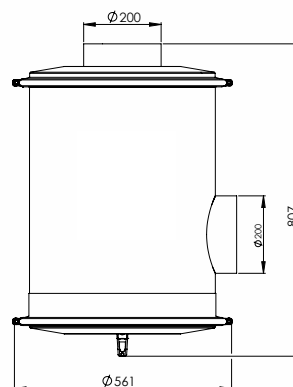

Contamination free

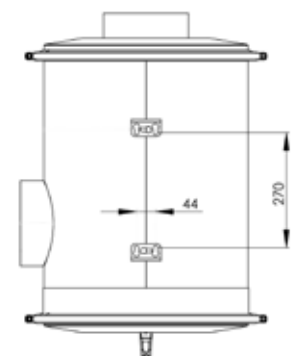

Wall Mounting

📄 Technical data

Inlet/outlet	Ø 200 mm
Height	810 mm
Diameter	577 mm
Weight	86 lbs/39 kg
Filter area	10.2 m ²
Airflow	2500 m ³ /h
Negative pressure	40 kPa
Filter type	HEPA H13 EN1822-1
Mounting	Wall and ceiling

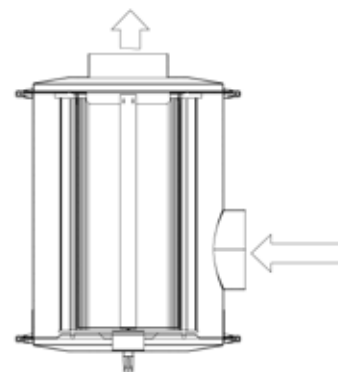

Air flow

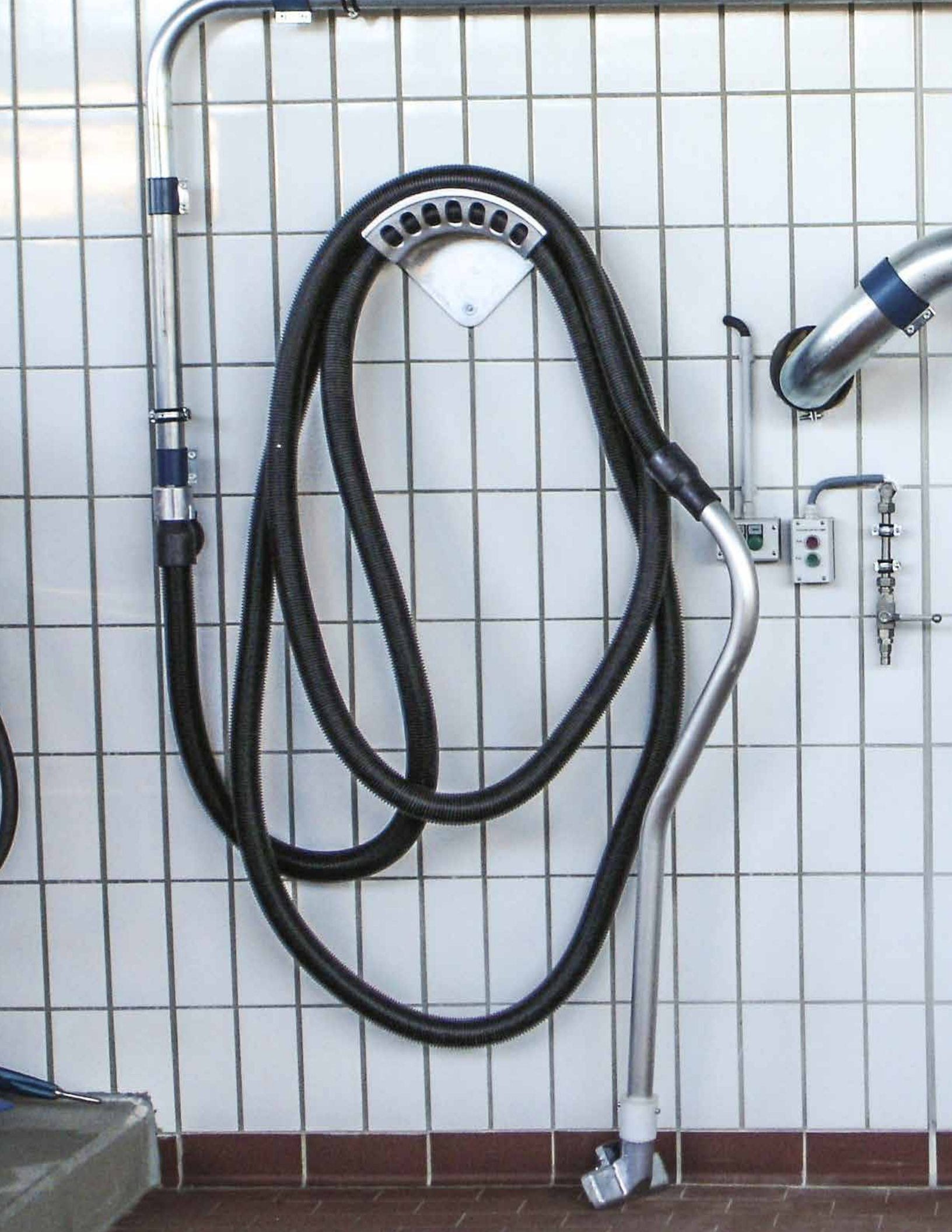

Healthy Business

Dustcontrol

Pre-Separators

When large quantities of material are to be separated, it is advisable to use a pre-separator. The pre-separator can be placed at the workplace or in conjunction with the central unit.



Dustcontrol

Dustcontrol

Dustcontrol

About Pre-Separators

Pre-Separators can be used in all applications where the extracted material is coarse or voluminous. These can be placed in the actual workplace for separate handling or recovery of the extracted material, or centrally.

Pre-Separators separate material from the air flow using the action of a cyclone or with inertial separation. Inertial separators are generally configured as containers with the inlet and outlet in the same wall of the container. When the air flow changes direction abruptly, separation occurs for the particles with higher relative mass.

When pre-separation is used to accommodate higher material volumes it is also important to consider the type of material discharge to be used. Dustcontrol offers a range of different standard options including; screw compaction, airlocks or container collection.

When a Pre-Separator is to be used the following should be considered:

1. Type of dust to be handled.
2. How the unit should be placed and how emptying will be performed.
3. Expected airflow.

Pre-Separators should be used:

- for material recovery
- for material transportation
- to reduce the loading on the ducting system
- to relieve loading on the central filter
- to reduce the risk of filter clogging
- when fluids are to be separated



Cyclone Principle meaning that the inlet is mounted tangentially on the body and the air flow is thus forced against the inside of the cyclone.

This principle is very effective in separating particles down to 1/100 mm.

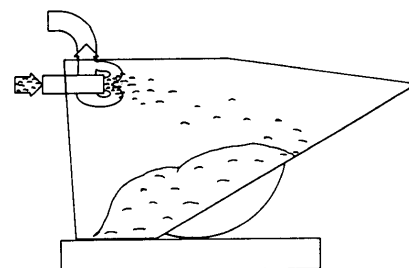

Inertial Principle meaning that the air stream flows into the container and abruptly changes course.

The outlet sits behind the inlet and the particles are thus thrown into the container.

Pre-Separators

Cyclone Pre-Separators



Type of material	Air flow (m ³ /h)	Select Pre-Separator
All types, particularly where a large percentage is fine particulate	100–200	DCF 60, F 2500, DCF 2800
	100–500	DCF Mobil
	200–500	F 3500
	500–700	F 8000
	500–1000	F 11000
	1000–4000	F 20000
	2000–5000	F 30000



Discharge to	Volume	Equipment
Plastic bag	lesser	Discharge cone
Compacted in plastic bag	greater	Auger Compactor
Open Container, Conveyor	lesser	Foot Valves/Auto Foot Valve/ Discharge Valves
	greater	Peristaltic Airlock
Small Container	lesser	With or without plastic bag
Tipping Container	greater	



Inertial Pre-Separators



Material type	Air flow (m ³ /h)	Volume	Select Pre-Separator
Coarse and dense	250-2000	moderate	Tipping Container
	250-2000	large	Large Container

Pre-Separators

DCF Mobile

The DCF Mobile is suitable for the separation of different types of coarse material, liquids and water. It is light and fitted with wheels, so it can be connected to the workplace directly, thereby reducing the loading on the ducting system and minimising the risk of blockage.

The DCF Mobile is the standard model of the mobile pre-separator. For emptying, the snap-on catches on the top cover are released and the material is shovelled or tipped out.

Part No	Type
7010	DCF Mobile Standard
7074	DCF Mobile Plastic Bag
7073	DCF Mobile Liquid Separator
7009	DCF Mobile Water Separator
7097	DCF Mobile Cyclone

Mobile with Plastic bag / 7074



The DCF Mobile complete with plastic bag has the same fittings as the standard model plus plastic bags and a pressure compensating hose in order to obtain the same vacuum outside and inside the plastic bag. This pre-separator is suitable for use when handling materials which need to be collected in a sealed package.

Mobile with Liquid Separator/ 7073



The DCF Mobile Liquid Separator is fitted with an intermediate grill and drain cock. It is suitable for handling chips where cutting fluids and coolants are also collected.

Mobile with Cyclone / 7097



The DCF Mobile Cyclone has a high efficiency cyclone mounted on the top cover. Thanks to the small diameter of the cylinder in relation to its height and to the specially shaped inlet, this separator can separate even smaller and lighter materials such as asbestos fibres. The separated material then falls into the container which is fitted with a plastic bag for dust-free handling.

Mobile with Water Separator / 7009



The DCF Mobile Water Separator is fitted with Ø 50 mm drain cock. This is used where large amounts of water will be separated.



Accessories (Part No)

4714 Collecting bag, 50 pcs for Pre-Separators 7074 and 7097



Technical data

see the following page

Pre-Separators

DCF Mobile



Technical data

DCF Mobile

Container volume	95 l/25.1 gal (US)
Height	900 mm/35.4 in/1650 mm/65 in (with cyclone)
Container diameter	440 mm/17.3 in
Weight	30 kg/66 lb/35 kg/77 lb (with cyclone)
Inlet/Outlet	Ø 76 mm/3"
Air Flow	100–500 m ³ /h 59-294 cfm

Dimensions

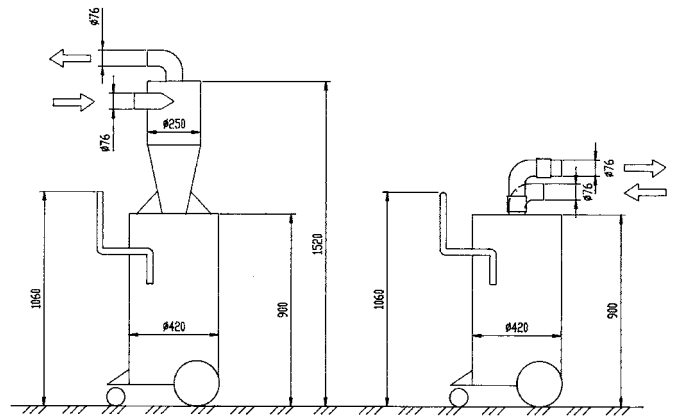

DCF 60

The DCF 60 Pre-Separator can handle large quantities of dust. Due to its large inlet the Pre-Separator is also well suited to separate coarse dirt. Perfect for wood floor grinding.

Part No 7069 DCF 60 with wheel set



Technical data

H x W x D (cm/inch)	106x38x38 / 42"x15"x15"
Weight	10 kg /22 lbs
Inlet	Ø50 mm /2"
Container	60 l /16 US gal

DCF 2800

The DCF 2800 Pre-Separator is often used in combination with the DC 2900 dust extractor to relieve the loading on the filter.

Part No 7372 DCF 2800



Technical data

H x W x D (cm/inch)	100x54x45 / 39"x21"x18"
Weight	10 kg /22 lbs
Inlet/Outlet	Ø50 mm /2"
Cyclone diameter	Ø250 mm /10"
Collection	40 l /10 US gal



Supplied with (Part No)

42702 Plastic bags

Pre-Separators

F 2500, F 3500

The F 2500 and F 3500 are wall mounted cyclone type pre-separators used directly at the work station to relieve loading on the tubing system/filter or for separation of recoverable material. These can also be used as central pre-separators in smaller systems with the DC 3800 and DC 11-Module respectively.

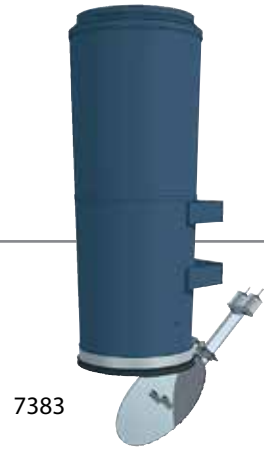

Dimensions, installation examples

Part No	Description
700501	F 2500
7061	F 2500, Fluid separator $\varnothing 76$
7379	F 2500 with Counter Balance Arrangement
706001	F 3500
7157	F 3500 Fluid separator $\varnothing 76$
7156	F 3500 with cone D=160
7383	F 3500 with Counter Balance Arrangement

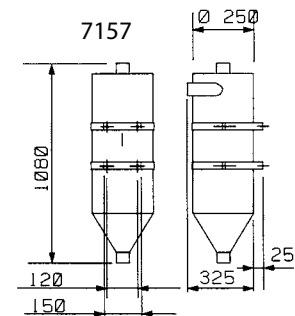
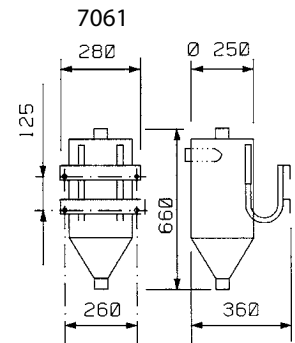
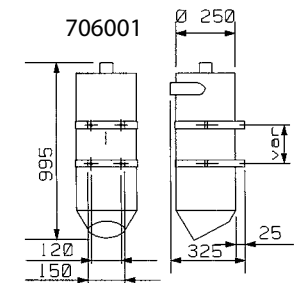
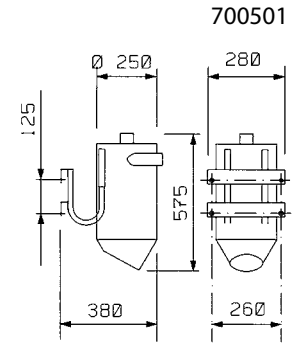
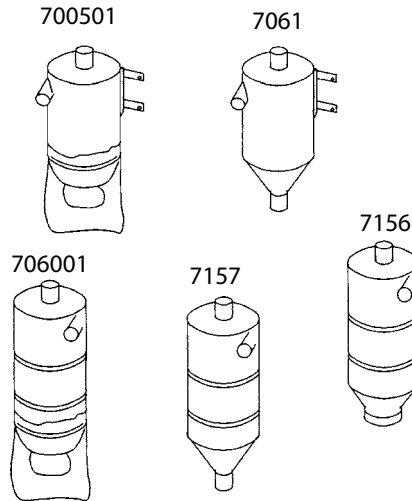

Technical data

	F 2500	F 3500
Weight, kg	5	13
In/outlet, mm	$\varnothing 50$	$\varnothing 76$
Air flow m^3/h	100-200	200-500



Accessories (Part No)

- 42384** Plastic Bag, F 2500, antistatic
- 4314** Plastic Bag, F 3500, 50 pcs
- 42702** IntelliBag 10 pcs/roll
- 706701** Discharge Valve 160 mm - AC
- 70670100** Discharge Valve 160 mm - DC
Installed for discharge to an open container. Controlled discharge can occur with this pneumatically actuated valve. Must be connected to a suitable control panel.
- 7128** Return Valve for Fluid Separator

42384/42702 4314



70601/ 7060100

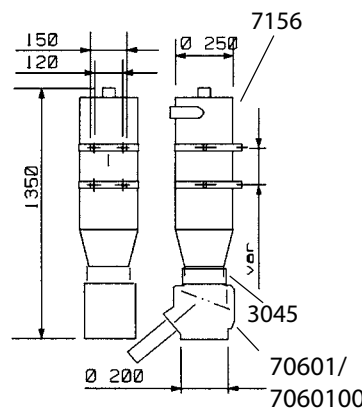
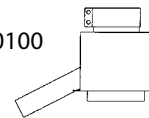

Pre-Separators

F 8000

The F 8000 is a high efficiency cyclone separator for the separation of fine and light dust, e.g. wood dust.

It can be equipped with a 40407 Module Ring to create a larger storage capacity. For alternatives to part no 746100, see discharge options.

Separation can be improved by equipping the Pre-Separator with a vortex tube and by increasing the height with an extra body module.

Part No 7450

F 8000 Complete is delivered with; 7344, 7345, 7461 and 2 x 3037

+ Accessories F 8000 (Part No)

- 3037** Bracket 500 mm (2 pcs required)
- 7290** Widening Chassis
- 7311** Vortex Tube
- 7344** F 8000 Cyclone
- 7345** F 8000 Body Module
- 40407** Module Ring. Used in applications with light dust, i.e. paper.
- 7450** F 8000 Complete
- 7461** Auto Foot Valve 470 mm, AC
- 746100** Auto Foot Valve 470 mm, DC

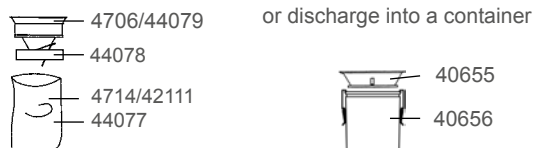
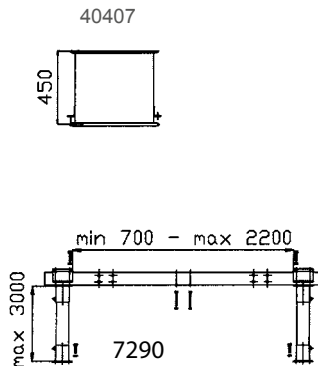

Technical data

F 8000

Weight, kg	~ 15
Inlet, mm	Ø 108
Outlet, mm	Ø 108
Flow m ³ /h	500-700
Body, Ø mm	Ø 300

Dimensions, Installation examples F 8000

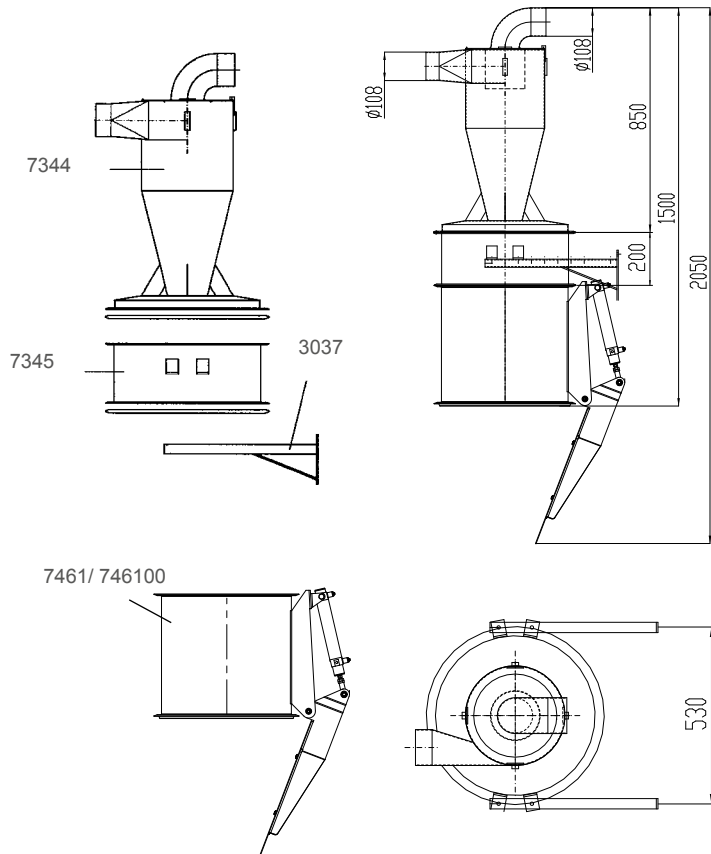

Pre-Separators

F 11000

The F 11000 is a modular cyclone pre-separator that is very flexible and can be configured easily to an exact requirement. Discharge equipment options can be used alternatively to the discharge cone with plastic bag collection.

Separation can be improved by equipping the pre-separator with a vortex tube and by increasing the height with an extra body module.

Part No	Description
7177	F 11000 without Cone
4706	Discharge Cone for bag
42111	Collection Bag, 50 pcs, antistatic
4714	Collection Bag, 50 pcs
5024	Wall Bracket, complete



+ Accessories F 11000 (Part No)

- 40407** Module Ring
Used in applications with light dust, i.e. paper.
- 40655** Discharge Cone for container
- 40656** Steel Container, 40 l
- 44077** Longopac Midi (1x25 m)
- 44078** Discharge Cone
- 44079** Discharge Cone Longopac Midi
- 7179** Floor Stand, complete
- 7290** Widening Chassis
- 7311** Vortex Tube



Technical data

F 11000

Weight, kg	ca 45
Inlet, mm	Ø 108
Outlet, mm	Ø 108
Flow m ³ /h	500-1000
Body, Ø mm	Ø 477

Dimensions, Installation examples F 11000

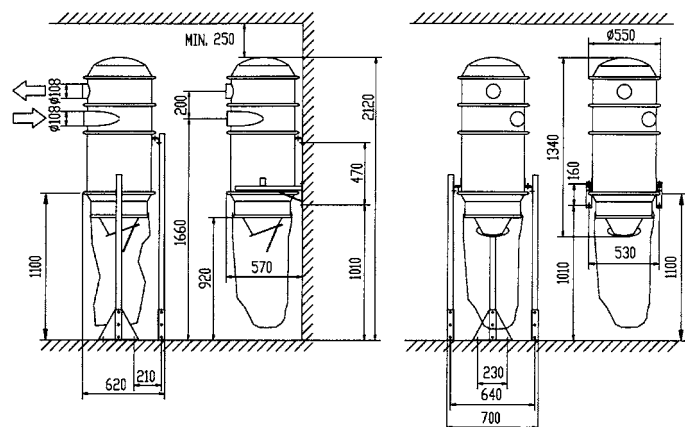
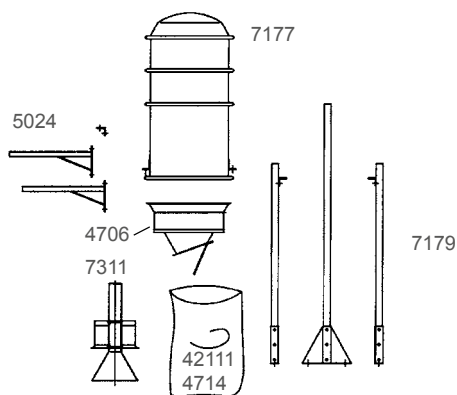

Pre-Separators

F 20000

The F 20000 is a modular cyclone separator for larger systems. The unit must be equipped with the appropriate inlet module and discharge arrangement, e.g.: discharge cone or alternative selection. See chapter 6.

Part No	Description
7185	F 20000 Complete
4706	Discharge Cone
4714	Collection Bag, 50 pcs
42111	Collection Bag, 50 pcs, antistatic
40655	Discharge Cone for container
40656	Steel Container, 40 l



Accessories F 20000 (Part No)

- 40007** Inlet wear plate
- 44077** Longopac Midi (1x25 m)
- 44078** Longopac Holder
- 44079** Discharge Cone Longopac Midi
- 7133** Inlet D = 160x1
- 7134** Inlet D = 250x1
- 7136** Inlet D = 76x3
- 7137** Inlet D = 110x2
- 7138** Inlet D = 110x3
- 7141** Inlet D = 160x2
- 7142** Inlet D = 160x3

7189 Vortex Tube
Used in applications with light dust, e.g. paper, to increase separation efficiency of the separator.

7195 Widening Chassis
For applications where material is to be discharged into a larger receiver such as a tipping container. "With legs >3000 mm a widening chassi should be ordered."

3004 Steel Tube 76 mm, galvanised. Ordered by the meter and delivered in 3 m lengths. Used when leg length required is greater than the 1400 mm legs delivered with the unit.



Technical data

F 20000

Weight, kg	120
Inlet, mm	optional
Outlet, mm	Ø 250
Flow m ³ /h	1000-4000
Body, Ø mm	Ø 596

Dimensions, Installation examples F 20000

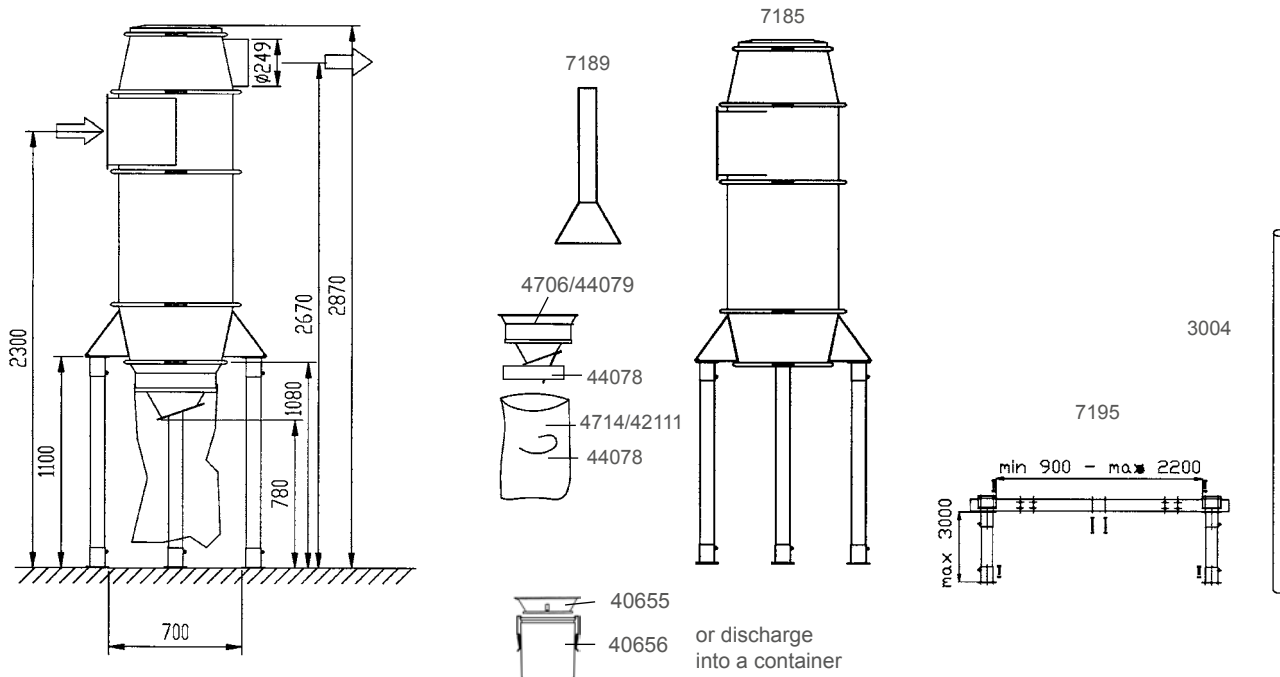

Pre-Separators

F 30000

The F 30000 is a modular cyclone separator for large systems. The configuration of the separator is easily tailored to the specific application. The unit must be equipped with the appropriate inlet module and discharge arrangement, e.g.: discharge cone or alternative selection.

Part No	Description
7166	F 30000
4706	Discharge Cone
4714	Collection Bag, 50 pcs
42111	Collection Bag, 50 pcs, antistatic
40655	Discharge Cone for container
40656	Steel Container, 40 l



F 20000

Technical data

F 30000

Weight, kg	ca 170
Inlet, mm	optional
Outlet, mm	Ø 250
Flow m ³ /h	2000-5000
Body, Ø mm	Ø 1045

Accessories F 30000

- 7133 Inlet D = 160x1
- 7134 Inlet D = 250x1
- 7136 Inlet D = 76x3
- 7137 Inlet D = 110x2
- 7138 Inlet D = 110x3
- 7141 Inlet D = 160x2
- 7142 Inlet D = 160x3

Inlet modules for F 20000 and F 30000

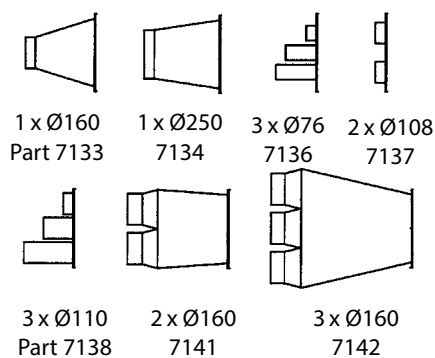

7166

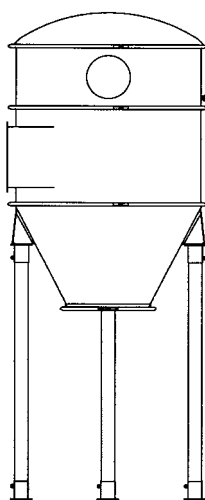

Components F 30000

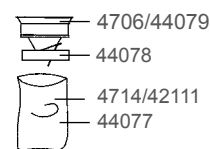

or discharge into a container

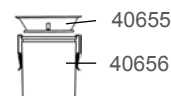

+ More accessories for F 30000 on the following page

Pre-Separators

F 30000

+ Accessories F 30000 (Part No)

3004 Steel Tube 76 mm, galvanised
Ordered by the metre and delivered in 3 m lengths. Used when leg length required is greater than the 1400 mm legs delivered with the unit.

3294 Spiral tubing \varnothing 315
For connection to pressure relief module.

40007 Inlet Wear Plate. This is installed in the inlet module of the separator and increases the resistance to abrasion caused by incoming material in the gas flow.

- 40655** Discharge Cone for container
- 40656** Steel Container
- 42111** Collection Bag, 50 pcs, antistatic
- 44077** Longopac Midi (1x25 m)
- 44078** Longopac Holder
- 44079** Discharge Cone Longopac Midi

4612 Body Module
Increases the height of the cyclone and can increase separation efficiency for some materials.

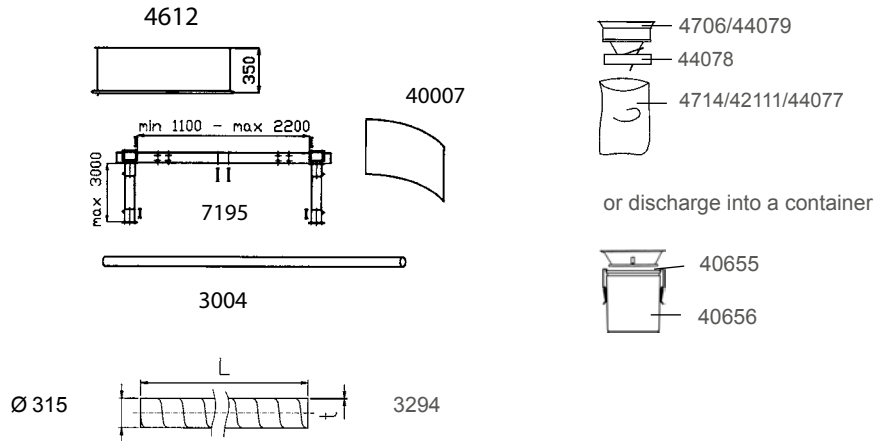

- 4706** Discharge Cone
- 4714** Collection Bag, 50 pcs

7195 Widening Chassis
For applications where material is to be discharged into a larger receiver such as a tipping container. For leg lengths greater than 1400 mm, order part no 3004 steel tube.

Dimensions, Installation examples F 30000

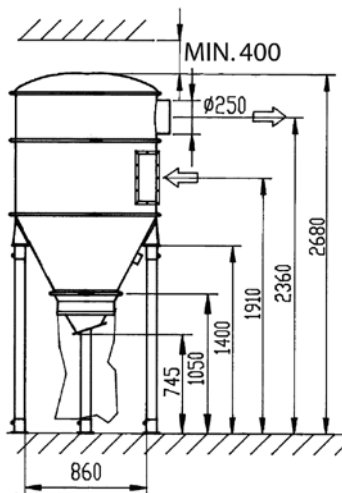

F 30000 with part no 4706 Discharge Cone

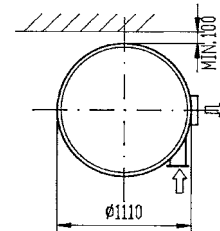
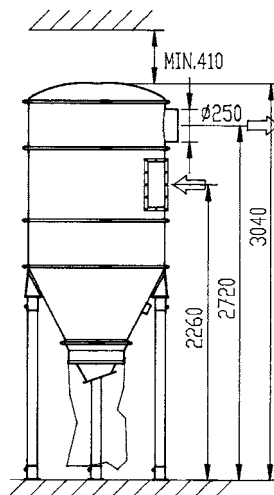

F 30000 with part no 4706 Discharge Cone and 4612 Body Module

Discharge Arrangements Suitable for

F 8000, F 11000, F 20000, F 30000, S 11000, S 32000, S 34000, S 46000

+ Accessories S 11000, S 32000, S 34000 (Part No)

706801 Reduction Cone 400/160 mm
706701 Discharge Valve 160 mm - AC

70670100 Discharge Valve 160 mm - DC
 This automatically controlled, pneumatically actuated valve can discharge collected material from the separator when the system is at rest. It is used for discharge into an open container or conveyor. The material must have good flow characteristics.

7131 Counter Balance for Discharge Cone (Part No 4706)
 The rubber flap on the discharge cone is replaced with the counter balance flap. This unit will close when the system is under operation. When the system is at rest, collected material will be discharged into an open container. **Note:** only for use with suitable materials.

7370 Discharge Valve 250 mm - AC
737000 Discharge Valve 250 mm - DC
7341 Discharge Valve 400 mm - AC

734100 Discharge Valve 400 mm - DC
 This automatically controlled, pneumatically actuated valve can discharge collected material from the separator when the system is at rest. It is used for discharge into an open container or conveyor. The material must have good flow characteristics.

7461 Auto Foot Valve 470 mm - AC

746100 Auto Foot Valve 470 mm - DC
 This is an automatically controlled, pneumatically actuated foot valve that opens when the system is at rest. It is used for the discharge of materials into an open container and should be used only with materials that will flow.

7462 Counter Balance Foot Valve 470 mm. This arrangement replaces the standard cone and functions by closing

automatically when the system is in operation and releasing collected material when the system is at rest. **Note:** only for use with suitable material.

741401 Manually actuated Intermediate Assembly
 In applications where the collected material receiving container is placed under system vacuum, this intermediate part is required to facilitate the easy removal of the waste container. It has a telescopic mating flange that is raised and lowered onto the container flange with two opposing eccentric locking mechanisms.

743200 Pneumatically actuated Intermediate Assembly
 The identical telescopic function and application to part no 741401 but actuated pneumatically rather than manually. The pneumatic cylinders can be controlled manually with a part no 8040 or with an automated control.

Part no 743200 does not include the actuator, this must be determined during the control design and ordered separately.

Discharge Valves

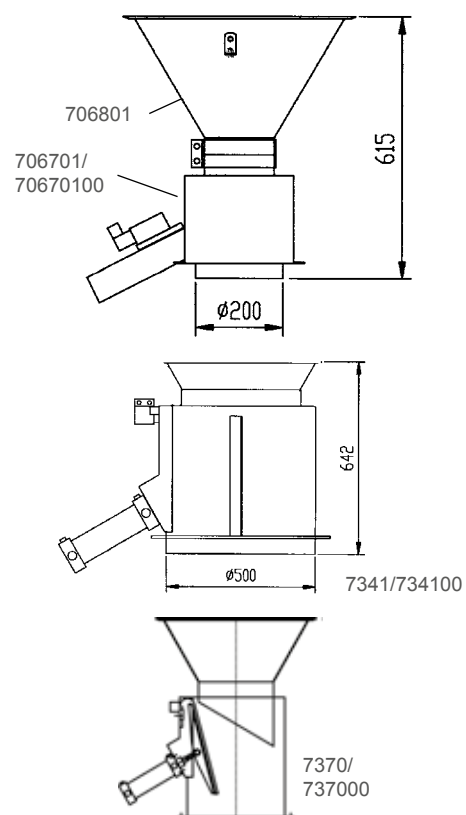

Optional configurations

In certain applications, automatic discharge during operation can be achieved by using a peristaltic airlock. Collected material can be discharged into a Big Bag.

Continuous Discharge Arrangements Suitable for

F 8000, F 11000, F 20000, F 30000, S 11000, S 32000, S 34000, S 46000

Peristaltic Airlock for Discharge of Dust from Filter Cyclone and Pre-Separator

Continuous discharge of material during operation can be achieved by installing two valves in series with an intermediate receiver. The material must be of such a nature that it flows easily.



Technical data

	Ø 160	Ø 250	Ø 400
Volume of receiver	12 l/3.17 gal	110 l/29 gal	190 l/50 gal
Air Consumption/cycle (5 bar/2.5 psi)	5 l/1.3 gal	15 l/3.96 gal	60 l/15.85 gal
Solenoids 24 V DC	2 pcs	4 pcs	4 pcs
Service interval	1 year	1 year	1 year

(Single shift operation)



Accessories (Part No)

- 40407** Storage Module, V=140 l
- 706801** Reduction Cone, 400/160 mm
- 708800** Peristaltic Airlock, 160 mm - AC
- 7342** Peristaltic Airlock, 400 mm - AC
- 734200** Peristaltic Airlock, 400 mm - DC
- 7362** Peristaltic Airlock, 250 mm - AC

736200 Peristaltic Airlock, 250 mm - DC
 This airlock consists of two 400 mm discharge valves and auto shutter valves for pressure compensation of the valves. The airlock is delivered complete with a control solenoid block. The lower discharge valve must be guyed and unweighted to the chassis or legs.

70880000 Peristaltic Airlock, 160 mm - DC
 The Peristaltic Airlock 160 mm is delivered complete with solenoid valves for actuation. A separate control must be selected.

Dimensions, Installation examples

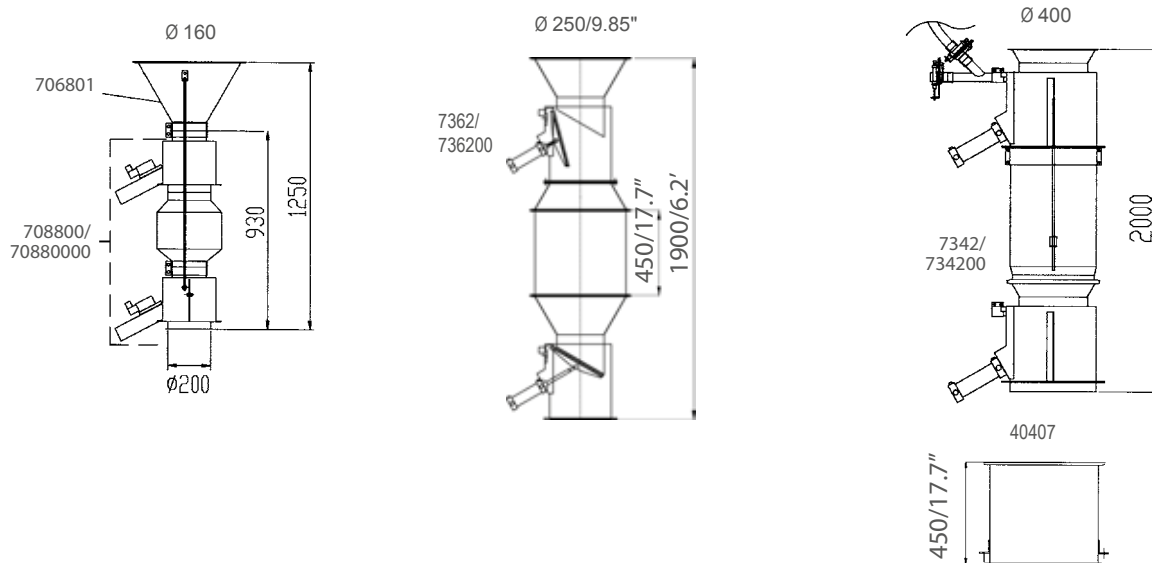

Continuous Discharge Arrangements

Suitable for
F 8000, F 11000, F 20000, F 30000, S 11000, S 32000, S 34000, S 46000

Dimensions, Installation examples

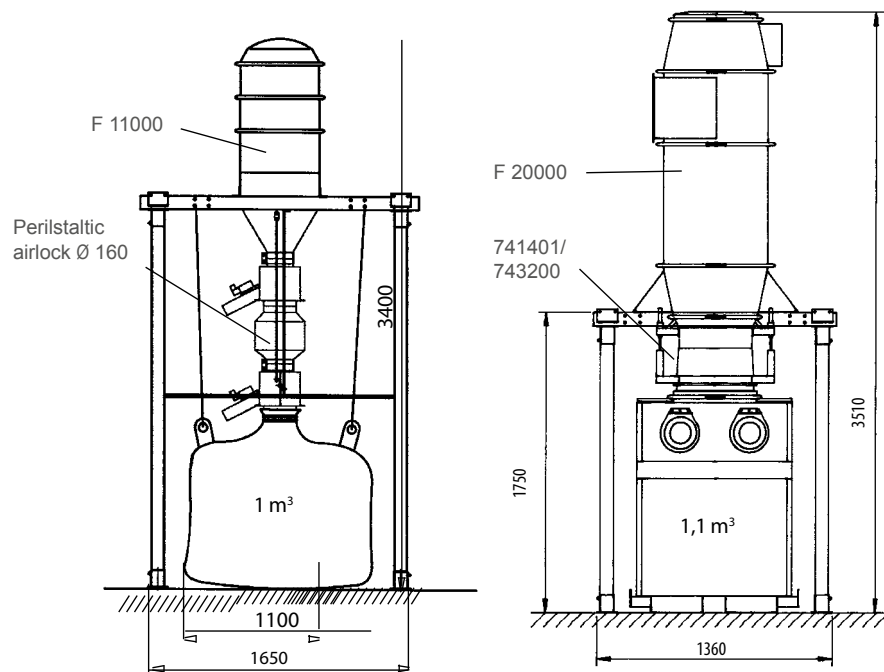

F 20000 with widening chassis and discharge into a 1.1 m³ container.

Auger Compactor

This arrangement is used for material that can be compacted, e.g. paper dust and strips. Collected material is compacted and discharged into a plastic collection bag. The drive motor control should be configured to reverse for several seconds to clear occasional clogs.



Technical data

Flange, outer mm	500x500
Inner mm	425x425
Weight	218 kg
Capacity	2-5 m ³ /h
Motor power	2.2 kW
Voltage	230/400V
Max Op. pressure	40 kPa
Service interval	1500 h

(1st service 300 h)

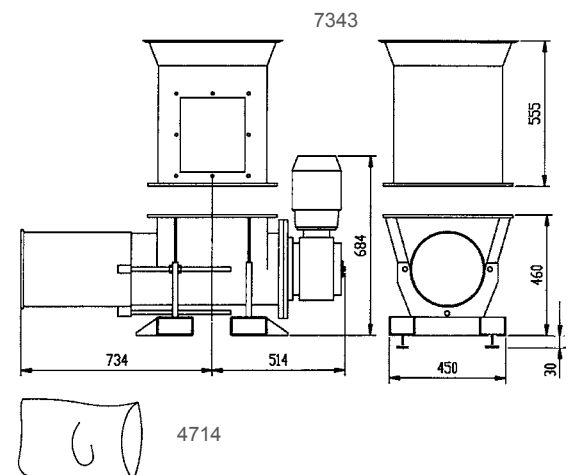

Part No	Description
4714	Collection Bag, 50 pcs
7343	Auger Compactor Connection
7065	Auger Compactor

Small Containers

The steel collection containers are mounted directly under the cyclone by using part no 4749 Adapter. Consider always the weight of the collected material and plan emptying of the container at suitable intervals.

Note: installation of part no 7160 requires lengthened legs on the F 20000 and F 30000.

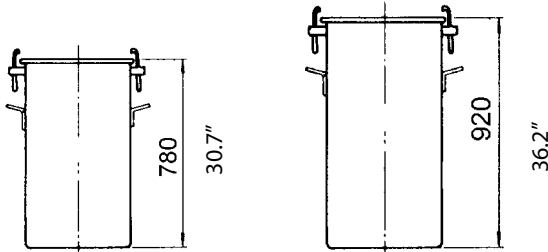
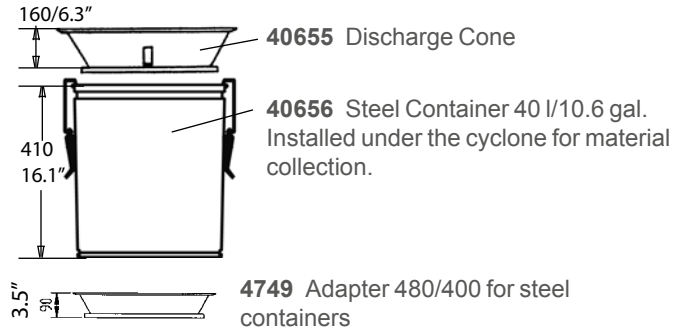

7066 Steel Container 90 l/23.8 gal.

7159 Steel Container 110 l/ 29 gal, with Collection Bag.
7368 Steel Container, 75 l, with Collection Bag.

7160 Steel Container 110 l/ 29 gal. Portable with Collection Bag.

7368 Steel Container, 75 l. Portable with Collection Bag.

4714 Collection Bag, 50 pcs for part no 7159 , 7160 and 7368.
42111 Collection Bag, 50 pcs, antistatic for part no 7159, 7160 and 7368.

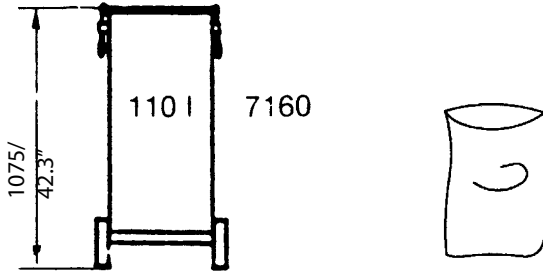

Small Container



Accessories Small Containers (Part No)

- 40655** Discharge Cone for container
- 40656** Steel Container
- 42111** Collection Bag, 50 pcs, antistatic for part no 7159, 7160 and 7368
- 4714** Collection Bag, 50 pcs for part no 7159, 7160 and 7368
- 7066** Steel Container 90 l/23.8 gal.
- 7159** Steel Container 110 l/ 29 gal with Collection Bag
- 7160** Steel Container 110 l/29 gal. Portable with Collection Bag
- 7368** Steel Container, 75 l
- 7433** Adapter 442/11000 Module

Tipping Containers 0,6 m³, 1,1 m³, 2,5 m³

Tipping containers are sealed to the cyclone bottom cone with an intermediate connection and adapter. Material is continuously collected in the container. A widening chassis must be used to install the cyclone to accommodate the width of the container.

Tipping containers can be used as inertial separators by equipping the container with a divider plate and installing inlet/outlet connections on the container's rear wall. Inertial separation is particularly suited to the separation of larger quantities of coarse material.

The divider baffle, 7439, is installed internally in the container between the inlet and outlet. The containers are tip-dump style and should be handled with a forklift truck. These containers can be equipped with casters.



Tipping Container

Part No	Capacity
7196	0.6 m ³ /0.78 yd ³
7197	1.1 m ³ /1.44 yd ³
7198	2.5 m ³ /3.27 yd ³
7439	Divider Baffle



Accessories Large Containers (Part No)

743200 Automatic Intermediate Connection

Secured automatically in the down position by two pneumatic cylinders when the container is present. Can be controlled with a manual pneumatic valve, part no 8040 or by an optional automatic control.

7433 Adapter 442/11000 Module

741401 Manual Intermediate Connection

Secured with two eccentric locks that are locked down when the container is present.

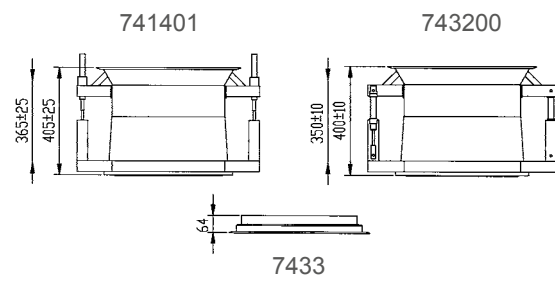
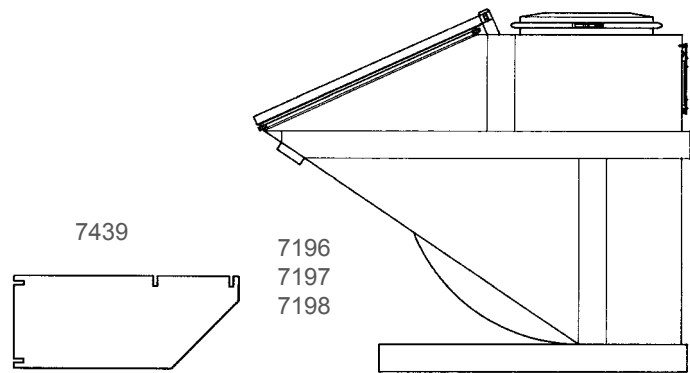

Tipping Containers 0,6 m³, 1,1 m³, 2,5 m³



Technical data

	m ³ /yd ³ (Collection volume)	m ³ /yd ³ (Filling volume)	kg (Volume)	kPa (Max-neg pressure)	A	B	C	E	F	G	H	J	K	L
7196	0.6/0.78	0,3/0.39	240	40	100	1076	X160	300	730	935	1180	200	1250	1590
7197	1.1/1.44	0,6/0.78	350	40	100	1096	X160	300	730	1050	1295	200	1550	1800
7198	2.5/3.27	1,3/1.7	570	40	100	1276	X160	300	730	1225	1470	200	1550	2180



Accessories for Tipping Containers (Part No)

7448 Cyclone Top

To increase separation efficiency, a cyclone top can be installed on the tipping container. The container then functions as a cyclone separator with a large storage volume for collected material. Suitable air-flows are between 400–800 m³/h.

7404 Caster Set (4 pcs),
max. 1600 kg

7422 Caster Set (4 pcs),
max. 2200 kg

7434 Container Guide Rails

These rails should be anchored to the floor using sleeve or wedge anchors (20 required).

7436 Hose Nipple, 76/X160

7437 Hose Nipple, 102/X160

7438 Hose Nipple, 152/X160

Accessories; bottom screen, drain cock and level sensing available by special order.

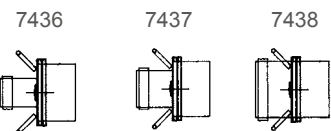
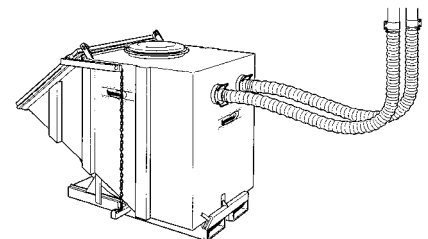
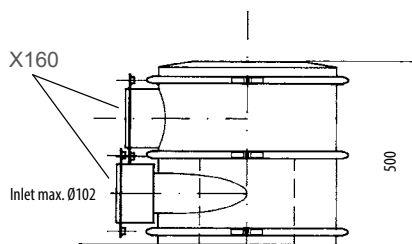
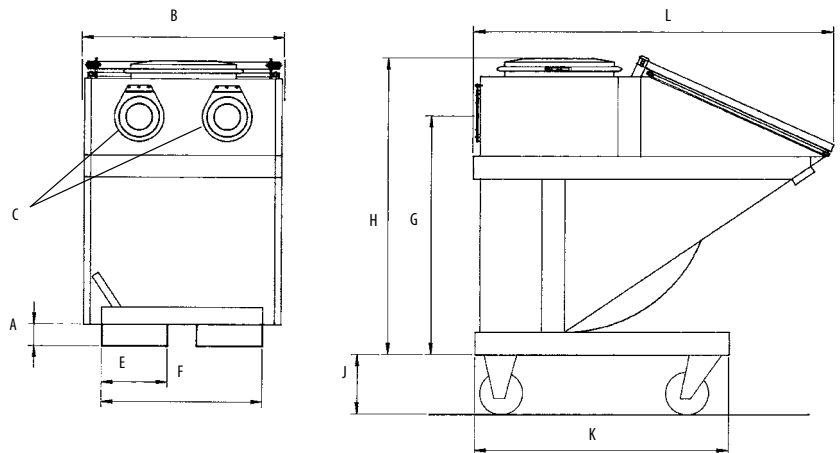

When the container is configured as an inertial separator, two hoses are connected to the rear wall of the container. Material is separated with inertial action as air entering the container changes direction abruptly.



Airflow, m ³ /h	Hose, Ø mm	Type, m ³
250-500	76	0.6; 1.1; 2.5
400-900	102	1.1; 2.5
900-2000	152	2.5

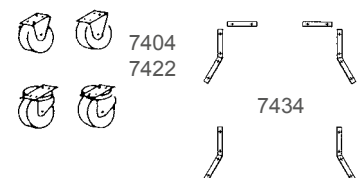

Large Containers

By installing inlet/outlet connections on larger containers (4-20 m³) an efficient inertial separator is built. Separation and containment of extracted waste directly in a closed container is a desirable handling method for a variety of reasons. Among these is that the system remains closed and that the handling of the waste can be done both rationally and economically.

These containers can also be used as discharge arrangements for cyclones – direct connection from the separator mounted over the container.

A vacuum waste container is an integral part of the extraction system and must be designed for the negative pressure.

Different regions and waste handlers will have different handling systems, the illustrations below show several different prevalent variations.

The exact type and dimensions of that type are often determined in cooperation with the contracted waste handler. Dustcontrol can build your bespoke container.

The following factors will have a bearing on the selection of container type:

- 1) Tipping cost.
- 2) Tipping in a pccer truck or removal.
- 3) Distance to tipping site.
- 4) Density and weight of the separated material.
- 5) Permits required for dumping of collected material (degree of hazard classification).
- 6) Time for removal of container and the need for two containers.
- 7) Physical placement of the container, is it accessible for the handling truck?



Lugger Lift

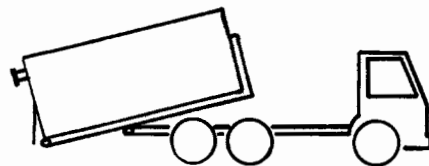

Roll Off Container

+ Accessories for Large Containers (Part No)

- 2010 Suction Hose 152, std
- 2011 Suction Hose 102, std
- 2033 Suction Hose 102 extra abrasion resistant
- 2045 Suction Hose 152 extra abrasion resistant
- 2046 Suction Hose 76 extra abrasion resistant
- 2056 Suction Hose 76 PU
- 3007 Joint Ø 76
- 3031 Joint Ø 108
- 3045 Joint Ø 160
- 3300 Pipe fitting 108/102
- 7404 Wheel Set, 4 wheels
- 7419 HD Hose Clamp 76
- 7420 HD Hose Clamp 102
- 7421 HD Hose Clamp 160
- 7422 Wheel Set 2,5 m³
- 742301 Pipe fitting 160/152
- 7436 Hose fitting 76/X160
- 7437 Hose fitting 102/X160
- 7438 Hose fitting 152/X160
- 7448 Cyclone Top

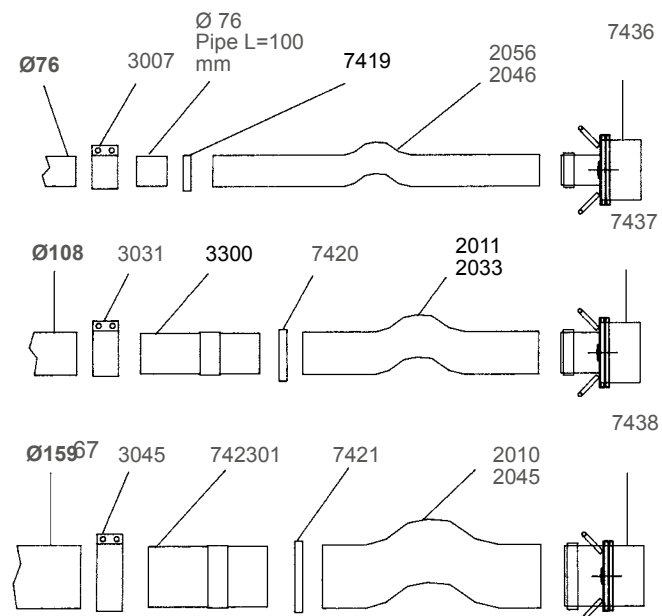

Optional accessories: Bottom grate, drain valve, tip sensor and level sensor, can be specially ordered.



Dustcont

STOLL

1000 kg

Healthy Business

Dustcontrol[®]



Compact Vacuum Systems

Substantial savings can be realised by installing a compact central vacuum system from Dustcontrol. For example, all grinders and finishing tools in an production facility are equipped with suction casings and connected to a central vacuum system. Capture of the dust at source contributes to an improved working environment, higher productivity, shorter clean-up, cleaner process and improved product quality.

About Compact Vacuum Systems

1 Vacuum Producer

The vacuum producer is a direct driven turbo pump. It is highly durable and has minimal service requirements. The characteristic of this type of vacuum producer makes it excellent for use with a VFD. With the frequency converter option the performance capacity will be optimised.

2 Filter Unit

The filter unit separates the larger particles in the cyclone and the finer dust in the pleated conical filter. The filter is cleaned very effectively with reverse pulse. The filter unit separates everything from fine dust to chips and fluids.

3 Control Panel

The electrical function is built into the machine. The unit is started manually with a start button, automatically when any of the extraction points are opened and microswitches are used or by clock control. Filter cleaning is automatic after shutdown of the vacuum. With the DC Green System option you get on-demand control for saving energy. You can also choose if the unit should be a fixed installation or mobile and be delivered with a Euro connection.

4 HEPA Filters

The fine filter separates a large quantity of the fine dust, but has a limited efficiency on the smallest particulate. In order to capture this particulate, the unit should be equipped with a HEPA filter. We always recommend that a HEPA filter be used when the system air is returned to the plant environment. With designated or hazardous dust we recommend the use of a HEPA filter even if the system air is to be vented out of the plant. (Note: Always be aware of and comply with local regulations.).

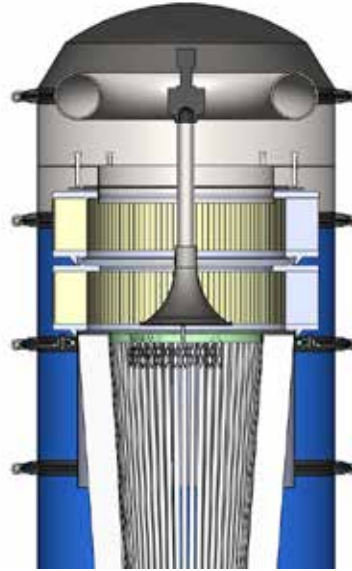

5 Outlet/Exhaust

For fixed installed extraction systems it is always recommended to exhaust the air out of the building if a HEPA is not used. In doing that, all residual particulate and any gases extracted are expelled from the building. With the help of a HEPA filter, almost all the particles can be eliminated. In a large plant, exhausting to atmosphere can sometimes be difficult. In these cases exhaust directly at the unit can be considered. Extra duct work and optional silencing is available to suit the installation.

6 Discharge of Material

Discharge of dust, fluids and heavy material is done under the cyclone. A number of different solutions can be chosen. The most common is plastic bag or container. Containers are available with a variety of volumes.

7 Mobile Unit

The DC 11-Module is designed with a pallet format chassis so it can easily be moved with a fork truck or pallet jack. By choosing to equip the unit with wheels and handle, a mobile unit is created that even with its large size and weight, is possible to move easily by hand on the production floor. There is also the possibility to create a semi-mobile unit where the unit is configured as a portable but docked to an installed tubing system. When it is required elsewhere, un-dock it, and wheel it away.

Compact Vacuum Systems

DC 11-Module

The DC 11-Module is a complete central unit for source extraction and industrial cleaning. The unit can manage just about every kind of dust and chip you can imagine, and when properly equipped, your coolants and emulsions too. With the DC 11-Module, we deliver a complete central unit from the factory, plug and play – easy to install. We tailor it exactly to your specific needs. This is possible due to an options based selection process. The DC 11-Module has been designed to produce more capacity/Hp and service up to six normal extraction points or several cleaning outlets at a time. We've worked hard to get the standard sound level to just 65 dB(A).

Need a HEPA filter? – Just select it as an optional extra. The discharge system can be chosen in accordance with the material to be handled, making it easy for your people to maintain their equipment. The DC 11-Module is also suitable for source extraction and general cleaning in smaller production areas. Note that the unit can connect to many extraction points, as long as the number of users does not exceed the maximum capacity.

For energy saving and reliable remote activation of operation, the DC 11-Module is also available with the DC Green System.



Visit www.dustcontrol.com search **DC Green System** – for further info regarding your energy savings.



Optimised Stand-Alone Unit

The design of a source extraction system is always based on the specific need at each work place. It is then possible to design and install a central unit for several, or many, extraction points. Alternatively, maybe a stand-alone unit for a particular area is the best choice.

The advantage with stand-alone solutions is that you attain cleaner production one step at a time – as production requires it and as budget allows it. The DC 11-Module becomes part of the work cell or production machine and can be part of the flexibility of modern lean manufacturing and fast change-overs from part to part.

The DC 11-Module is developed to fulfil the demands of a local solution.

Compact Vacuum Systems

DC 11-Module



Standard functions

	Without system control 141xx6x, 141xx9x, 141xxAx	With direct start control 141xxfx	With motor controller soft start 141xxGx	With frequency inverter constant speed 141xxLx	DC Green System 141xxNx
Direct driven three phase turbopump - long life time	x	x	x	x	x
Sound absorbent around vacuum producer	x	x	x	x	x
Filter unit with separation of particles in cyclone and fine fraction particles in pleated filter	x	x	x	x	x
Main switch on panel*		x	x		
Soft start for turbopump			x		
Frequency inverter for start/stop and speed control				x	x
Constant rpm set from display				x	
Demand control according to DC Green System					x
Manual start and stop from panel front		x	x	x	
Programmable clock start/stop		x	x		option
Prepared for remote start with micro switches		x	x	x	x
Control for filter cleaning with air pulse		x	x	x	x
Prepared for filter cleaning during operation		x	x	x	x
Solenoid valve for filter cleaning in filter unit	24V DC	24V DC	24V DC	24V DC	24 VDC
Alarm indication		x	x	x	x
Timers adjusted from display		x	x	x	x
Pressure level adjusted from display					x
Thermal protection	x**		x**	x	x
Vacuum valve	x	x	x	x	
Roof hood	x***		x***	x***	x***

*) Please note that when main switch is not included it should always be assembled on the supply on the wall beside the unit.

**) Not for 5.5 kW

***) Only 5.5 kW and 7.5 kW

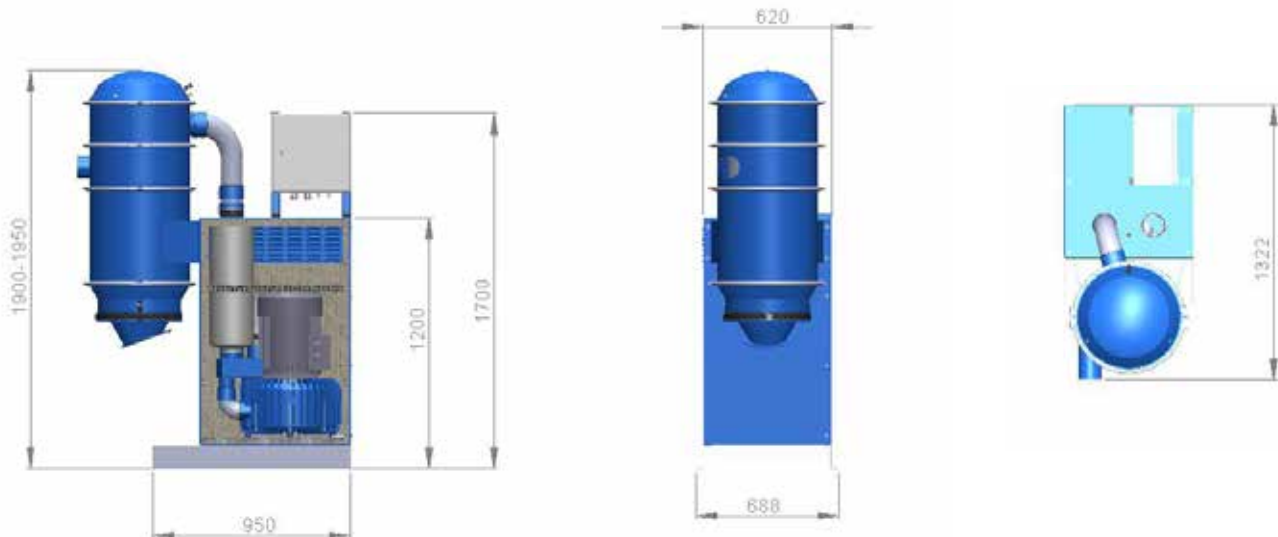

DC 11-Module Standard

Standard filter. Output in plastic bag (Discharge cone 4706), outlet, compressed air filter cleaning.

Part No	DC 11-Module standard
14123G00110	DC 11-Module 5.5 kW, 400V/50 Hz, with Softstart Control
14124L00110	DC 11-Module 7.5 kW, 380-480V, 50/60 Hz, with Frequency Converter constant speed
1412FA00110	DC 11-Module 10 hp, 230/460V/60 Hz, USA/CAN, without Control System
14146G00110	DC 11-Module 11 kW, 400V/50 Hz, with Softstart Control
1414P900110	DC 11-Module P 15 hp, 460V/60 Hz USA/CAN, without Control System
14136G00110	DC 11-Module S11 kW, 400V/50 Hz, with Softstart Control
1413P900110	DC 11-Module S 15 hp, 460V/60 Hz, USA/CAN, without Control System

Please contact your sales representative for further options and combinations.



Air pulse filter cleaning

Air consumption	4 l/s, 4 bar
Hose connection	6 mm



Filter material in pleated polyester All models

Part No	4292
Total filter surface	8.4 m ³
Degree of separation EN 60335-2-69 part 1	> 99.9%

Electric connection for all units is 24V DC.



Technical data

	5.5 kW	7.5 kW	10 hp	11 kW P	15 hp P	11 kW S	15 hp S
Motor	50 Hz	50 Hz	60 Hz	50 Hz	60 Hz	50 Hz	60 Hz
rpm	3000	3000	3600	3000	3600	3000	3600
Inlet/Outlet	Ø108/100	Ø108/100	Ø108/100	Ø108/100	Ø108/100	Ø108/100	Ø108/100
Max dp	22 kPa	22-18 kPa	22 kPa	22 kPa	20 kPa	40 kPa	43 kPa
Nominal pressure	18 kPa	18-17 kPa	18 kPa	18 kPa	18 kPa	30 kPa	32 kPa
Max Q	450 m ³ /h	450-550 m ³ /h	500 m ³ /h/295 cfm	800 m ³ /h	850 m ³ /h/500 cfm	450 m ³ /h	560 m ³ /h/330 cfm
Weight	200 kg	225 kg	225 kg	260 kg	260 kg	250 kg	250 kg
Sound level 1 m	60 dB(A)	63 dB(A)*	63 dB(A)*	63 dB(A)	64 dB(A)	63 dB(A)	64 dB(A)
Sound level with frequency inverter		60-65 dB(A)*		61-67 dB(A)		61-67 dB(A)	

*) Sound level with extra silencer on the outlet 5 dB(A) lower the given figure.

Compact Vacuum Systems

DC 11-Module XL

The DC 11-Module XL provides you with the same plug-and-play approach as its smaller sisters. It is equipped with the renowned S11000X filter unit and for the vacuum provider you can choose between the 15 kW (20 hp) TPR40 or the 18.5 kW (25 hp) TPR43. Discharge is optionally into a bag or 40 l container.



Part No DC 11-Module XL

151100	DC 11-Module XL 15 kW, 400V/50 Hz, bag, without control panel
151110	DC 11-Module XL 15 kW, 400V/50 Hz, bag, with control panel
151120	DC 11-Module XL 15 kW, 400V/50 Hz, bag, Green System
151200	DC 11-Module XL 15 kW, 400V/50 Hz, 40 l, container, without control panel
151210	DC 11-Module XL 15 kW, 400V/50 Hz, 40 l, container, with control panel
151220	DC 11-Module XL 15 kW, 400V/50 Hz, 40 l, container, Green System
152100	DC 11-Module XL 20 hp, 460V/60 Hz, bag, without control panel
152200	DC 11-Module XL 20 hp, 460V/60 Hz, 40 l, container, without control panel
153100	DC 11-Module XL 18,5 kW, 400V/50 Hz, bag, without control panel
153110	DC 11-Module XL 18,5 kW, 400V/50 Hz, bag, with control panel
153120	DC 11-Module XL 18,5 kW, 400V/50 Hz, bag, Green System
153200	DC 11-Module XL 18,5 kW, 400V/50 Hz, 40 l, container, without control panel
153210	DC 11-Module XL 18,5 kW, 400V/50 Hz, 40 l, container, with control panel
153220	DC 11-Module XL 18,5 kW, 400V/50 Hz, 40 l, container, Green System
154100	DC 11-Module XL 25 hp, 460V/60 Hz, bag, without control panel
154200	DC 11-Module XL 25 hp 460V/60 Hz, 40 l, container, without control panel



Technical data

	15 kW	20 hp	18.5 kW	25 hp
Motor, Hz	50	60	50	60
rpm	4000	4000	4300	4300
Inlet/Outlet Ø mm	108/160	108/160	108/160	108/160
Max dp (kPa)	26*	26	28*	28
Nominal pressure, kPa	20	20	20	20
Air flow, max Q m ³ /h	1000	1000	1000	1000
Sound level 1 m, dB(A)	66	66	66	66

* DC Green System max 22 kPa



Filter material in pleated polyester

All models

Part No	4284
Total filter surface	12 m ³
Degree of separation EN 60335-2-69 part 1	> 99.9%

Electric connection for all units is 24V DC.



Compact Vacuum Systems

Options DC 11-Module

Part Numbers	Example			
141236	1	0Q	1	0
Base unit	Filter	Discharge	Design	Options

C 11-Module	Base Unit	Filter	Discharge	Configuration	Special equipment
5.5 kW 400 V 50 Hz without any panel	141236				
5.5 kW 400 V 50 Hz with soft start panel	14123G				
7.5 kW 400 V 50 Hz without any panel	141246				
10 HP 230/460 V 60 Hz without any panel	1412FA				
10 HP 600 V 60 Hz without any panel	1412CA				
7.5 kW 380-480 V 50/60 Hz Frequency inverter Constant speed	14124L				
7.5 kW 380-480V 50/60 Hz Green System	14124N				
11 kW P 400 V 50 Hz without any panel	141466				
15 HP P 460 V 60 Hz without any panel	1414P9				
15 kW P 600 V 60 Hz without any panel	1414CA				
11 kW P 400 V 50 Hz with softstart panel	14146G				
11 kW P 380-480 V 50/60 Hz Frequency inverter Constant speed	14146L				
11 kW P 380-480 V 50/60 Hz Green System	14146N				
11 kW S 400 V 50 Hz without any panel	141366				
15 HP S 460 V 60 Hz without any panel	1413P9				
11 kW S 400 V 50 Hz with softstart panel	14136G				
11 kW S 380-480 V 50/60 Hz Frequency inverter Constant speed	14136L				
Filter Options					
Standard		0			
With HEPA		1			
PTFE		3			
Discharge					
Output in plastic sack (discharge cone 4706)			01		
Container 40 l; steel, blue			0 H		
Container 55 l; steel blue			0 Q		
Container 75 l; with plastic bag and wheel			21		
Design					
Compressed air filter cleaning				1	
Options					
Standard					0
Euro connection*					1

* Not for 11 kW/15 HP

Compact Vacuum Systems

DC 3800 Stationary 3-phase

The DC 3800 Stationary Package is intended for installations in (for example) industrial premises, garage workshops and schools. The dust separator and turbopump are mounted on a common chassis.

The DC 3800 Stationary Package has flow capacity for one work place at a time, for example a 6" cup stone or cleaning with 38 mm attachments. The filter is cleaned manually with a patented reverse pulse mechanism. The unit can be equipped with a vacuum relief valve to allow cooling air to the pump if all outlets are closed. The package is complete with tubing in three metre lengths, bends, branch pipes and connection joints.

Installation is simple and the tubing system is easily adaptable to most sites. Starting and stopping of the central unit occurs automatically. Starting occurs when any of the outlets are opened. The central unit will shut down when all the outlets are closed.



Part No Description

114700	DC 3800 STAT, 2.2 kW, 220/ 380V, Package, EU
117400	DC 3800 STAT, 2.2 kW, 220/ 380 V, EU
117408	DC 3800 STAT, 4 hp, 460V/ 60 Hz, UL,USA
118500	DC 3800 STAT, 2.2 kW, Automatic filter cleaning, 220/ 380 V
118504	DC 3800 STAT, Automatic filter cleaning, 460V/ 60 Hz, UL,USA
4314	Plastic Bag 30 l, 50 pcs

860



Technical data

	50 Hz	60 Hz
Height mm	1400	1400
Width mm	400	400
Length mm	860	860
Weight	50 kg	110.2 lbs
Inlet/outlet	Ø 50 mm	Ø 2"
Flow at open inlet	260 m³/h	188.3 cfm
Negative pressure	20 kPa	21 kPa
Power motor	2.2 kW	4 hp
Filter area, fine filter	1.8 m²	1.8 m²
Degree of separation	> 99.9%	> 99.9%
Collection bag	30 l	30 l
Sound level	< 75 dB(A)	< 75 dB(A)

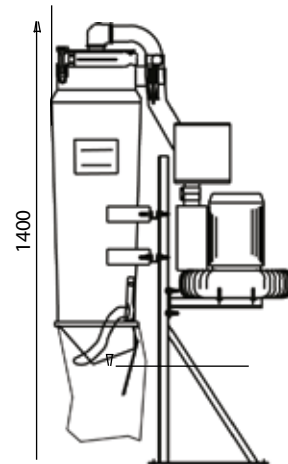



Central unit DC 3800 Stationary

Part No Qty

DC 3800 Stationary 230 /400V /50 Hz /2.2 kW	117400	1
DC 3800 Stationary 230 /460V /60 Hz /4 hp	117408	1
Control systems		
Control Panel 400V /50 Hz /2.2 kW	8117	1
Control Panel 230V /50 Hz /2.2 kW	8119	1
Connection Point		
Flap Valve Ø 50 with micro switch	8433	3
Tubing system		
Pipe Ø 50 (L=3 m)	3071	6
Bend Ø 50, 90°	3310	4
Bend Ø 50, 45°	307311	2
Joint Ø 50	3077	8
Branch pipe 50/50	307411	2
Coupling socket 50/50	2107	2
Hose Ø 50 (L=5 m)	2401	1
Hose clamp 50-65	4219	2
Bracket 300	3008	12
Clamping band Ø 50	3107	12
Ceiling attachment (L=2 m)	9622	1

The two conductor cable for 24 V is not included in the package (electrical and connection schematic are included with the panel).

The package consist of

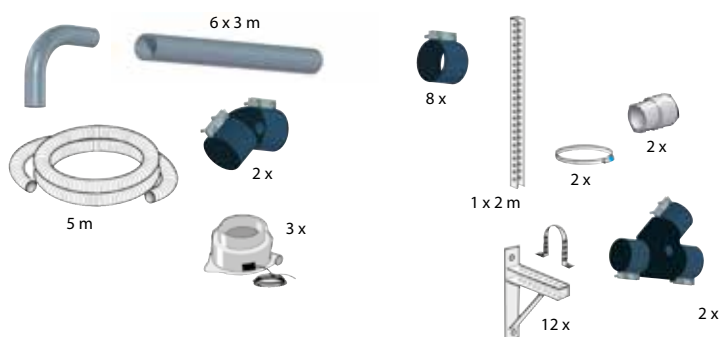

Accessories (Part No)

3195 Silencer 80 mm 300/180. Used for exhaust silencing and also silencing of 50 mm vacuum valve.

42024 HEPA Filter DC 3800/3900

42988 Silencing Cover. Suitable for 2.2 kW model only. The silencing cover will reduce the sound level 4 dB.

8132 Panel for remote start auto filter cleaning

8253 Vacuum Relief Valve 50 mm
The vacuum relief valve is installed on the tubing system (inlet side) on a branch tube. This delivers cooling air to the turbopump and can be adjusted for the desired vacuum level in the system.

8132 Starter DC 3800 Stationary 2.2 kW400V

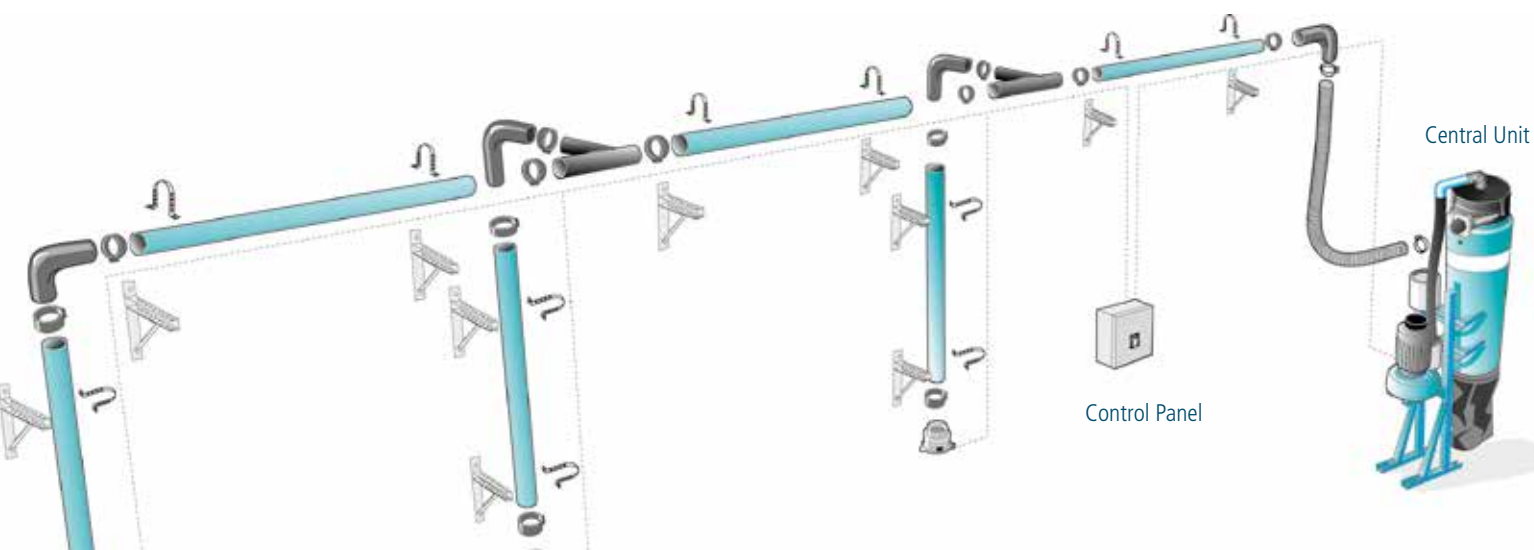
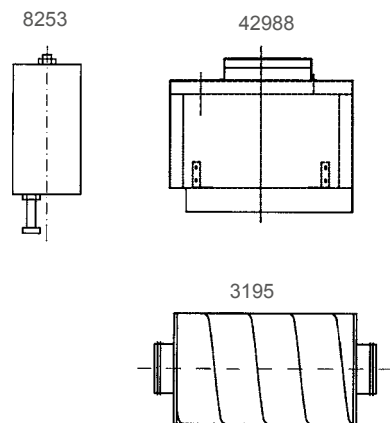

Compact Vacuum Systems

DC Box

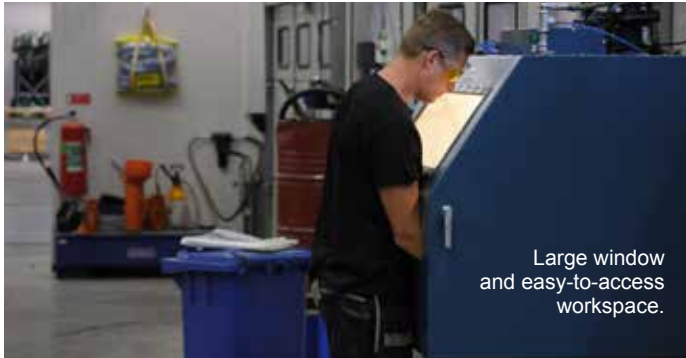

Large window and easy-to-access workspace.



Compressed air connection and blow gun nozzle. Suction hose for easy cleaning inside the cabinet.



Rotatable, sliding workbench.

The DC Box is a specially designed dust extraction cabinet that protects against hazardous dust during decontamination and cleaning before servicing or repairing machines and tools. The DC Box is equipped with a blow gun and a suction hose for vacuum cleaning. Larger particles and debris fall down into a plastic bag attached to the bottom of the cabinet.

The DC Box is easy to work with. Tools and machines are placed onto the rotating worktable and slid in through the side door. These are then cleaned either by vacuuming or using compressed air. The fine dust is vacuumed up and transported away via a tubing system to a complete central unit located either in or outdoors. The size of the central unit and dimensioning of the tubing system is tailored to the needs of the customer. The system can be expanded so that it can also be used as a central extraction system with connections that are easily accessible across the entire worksite.

The DC Box is available in three versions: small, medium and large.

The DC Box Small uses the DC AirCube 500 air cleaner as its vacuum source and it is easy to use in cramped premises where there is no room for tubing and a central dust extractor.

The DC Box Medium is the ideal solution for most users. Equipped with a pre-separator and DC 11-Module 11kW p/15 hp central unit.

DC Box Large. If you want to be able to roll taller equipment directly into the cabinet for decontamination, then the DC Box Large is the solution for you. DC Box Large is customized after your requirements.

Customized after your requirements



DC Box

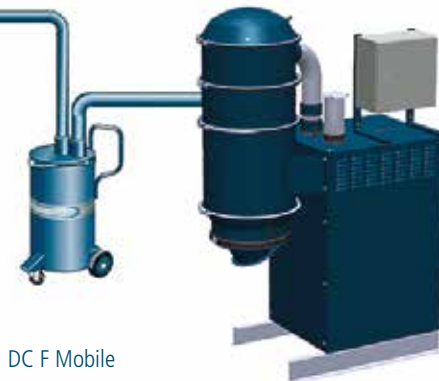

DC F Mobile

DC 11-Module



The DC Box Medium Package is supplied with (Part No)

- 7470 DC Box
- 42014 Trolley
- 7074 DC F Mobile Pre-Separator
- DC 11-Module 11 kW P central unit tubing system

Contact your sales representative for correct dimensioning and a quotation for DC Box Packages.



DC Box Medium
7470 DC Box standard



Technical data DC 11-Module 11 kW P/15hp

H x W x D (cm/inch)	180x100x130 /71"x40"x51"
Weight	260 kg /573 lbs
Inlet/Outlet	Ø180 mm /7"
Filter cleaning compressed air	4 l/s /3 804 gph
Flow	800 m³/h /28 250 ft³/h
Negative pressure, max	22 kPa /88 inwg
Filter area	8.4 m² /90.4ft²
Degree of separation	>99.9%
Sound level	60-63 dB(A)



DC Box Small Complete
with DC AirCube 500, 50 Hz
74701 230V EU, 74702 230V UK



DC Box Large
Customised to your requirements



Technical data DC AirCube 500

H x W x D (mm/inch)	380x340x495 /15"x13"x20"
Weight	13 kg/29 lbs
Inlet/Outlet	Ø380x340x495 mm
Max flow 230/115V	500 m³/h /470 m³/h



Technical data DC Box Medium and Small

H x W x D (cm/inch)	200x80x160 /79"x31"x63"
Weight	160 kg /353 lbs
Inlet/Outlet	Ø76 mm /3"
Hose length	2 m /6.5ft





Healthy Business

Dustcontrol

Tubing System

The tubing system transports the material from the point of collection to the central unit. Dustcontrol has a very comprehensive assortment of tubing fittings and installation hardware. This gives greater flexibility in design and installation of our tubing systems. Our mechanical jointing system makes alterations and additions very easy to implement.

About Tubing System

The tubing system transports the material from the point of collection to the central unit. Dust is generally abrasive, some more than others, therefore the standard material thickness of the tubing system is 1.5 mm. Applications with fume and light dust use reinforced spiral duct. Stainless tubing systems and extra abrasion resistant fittings are available.

Dustcontrol has a very comprehensive assortment of tubing fittings and installation hardware. This gives greater flexibility in design and installation of our tubing systems. Our mechanical jointing system makes alterations and additions very easy to implement.

Bends and branch pipes are designed to withstand high negative pressure. The bends are designed with a radial ridge to spread the impact area of the material thereby reducing wear and minimising the risk of blockage.

An effective tubing system has to meet certain requirements. Constant transport velocity in the tubing at different loads is one requirement. Correct transport velocity is another. When the velocity is too low, the material will cause a blockage. When the velocity is too high, this will lead to unnecessary wear and loss of energy. Dustcontrol's competent staff can dimension a system to your needs.

Tubing System Details

Steel Tubing

Our standard tubing system is of zinc coated carbon steel tubing and is used on 90 % of all Dustcontrol installations. Heavy wall thickness results in long life even in installations where considerable abrasion is present.

Stainless Steel Tubing

Stainless tubing is used with abrasive materials or because of hygienic considerations. When installed in material transportation, long radius bends should be used.

Reinforced Spiro Tubing

Spiro tubing is used most commonly for the connection of the central unit components, vacuum producer, filter unit and pre-separator. Spiro is not generally suitable for application with coarse and abrasive material but is commonly used in extraction systems for vapour, fume and light dust.

Mounting Hardware

Dustcontrol has a complete range of mounting hardware facilitating straightforward installation as well as changes

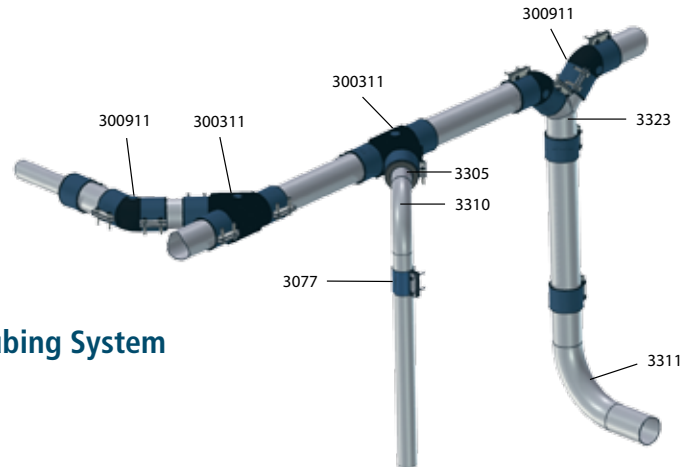

Elastomer Tubing System



Transport of

Transport of	Air Flow m ³ /h	Tube dimension mm	Description
Dust, coarse	(100-260	Ø 50)*	Steel Tubing
and heavy material	300-600	Ø 76	Steel Tubing
20-40 m/s	600-1200	Ø 108	Steel Tubing
	1200-2600	Ø 159	Steel Tubing
Fume, vapour	180-320	Ø 76	Steel Tubing
and clean air	320-550	Ø 100	Reinforced Spiral Tubing
12-20 m/s	370-620	Ø 108	Steel Tubing
	510-850	Ø 125	Reinforced Spiral Tubing
	840-1400	Ø 159 / Ø160	Steel Tubing/ Reinforced Spiral Tubing
	1300-2200	Ø 200	Reinforced Spiral Tubing
	2100-3500	Ø 250	Reinforced Spiral Tubing

*) On most systems, 76 mm should be selected as the smallest tube diameter. Only systems where a small air-flow is desired or installation is more easily facilitated should 50 mm be used.

Tubing System Details

When transporting material in a tubing system turbulent flow will cause noise. Material particles impact the hard tubing walls. Using an elastomer (EPDM- and NBR-rubber) in bends, branch pipes and mounting brackets moderates the sound considerably. Every elastomer bend and branch pipe are designed with a plugged hole that can be used for measuring and inspection.

Cones, branch pipes and bends are manufactured in EPDM- and NBR-rubber. The components are abrasion resistant and sound absorbing.

Steel Tubing System

Dustcontrol pipes are zinc coated carbon steel.
The material density gives the pipes a long life.

Tubing

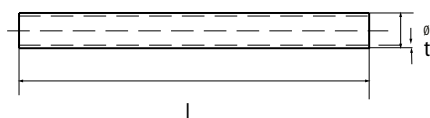

Part No.	Desc	Ø	l (m)	t	m (kg)
3071	Ø 50	50.8	3	1.5	1.8
3340**	Ø 50	50.8	0.135	1.5	1.8
3004*	Ø 76	76	3	1.5	2.6
3341**	Ø 76	76	0.135	1.5	2.6
3039*	Ø 108	108	3	2.0	3.9
3342**	Ø 108	108	0.135	1.5	3.9
3060	Ø 159	159	3	1.5	7.7

*) Full handle of 6 m lengths: Ø 76 - Part No 3278 (total 144 m); Part No 3279 (total 114 m)

**) Tube stub required when mounting a 45 bend directly to a branch pipe (only in polymer system)

Bend 90°

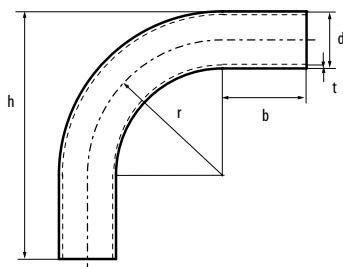

Part No.	Desc	Ø	r	b	h	t	m (kg)
3310	Ø 50	50.8	120	75	220	1.5	0.6
3309	Ø 50	50.8	85	75	185	1.5	0.3
3117	Ø 50	50.8	50	-	115	1.5	0.3
3118	Ø 76	76	65	-	150	1.5	0.6
3311	Ø 76	76	160	180	313	1.5	1.3
3005	Ø 76	76	175	-	213	2.9	1.45
3319	Ø 108	108	160	165	380	2.0	3.0
3061	Ø 159	159	375	-	455	4.5	10.1

Bend 90°, extended

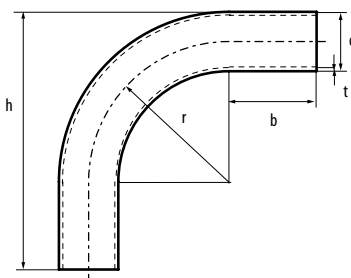

Part No	Desc	Ø	r	b	t	m (kg)
3169	Ø 76	76	175	150	2.9	3.0
3165	Ø 108	108	250	150	3.6	6.5
3161	Ø 159	159	375	150	4.5	15.3

All measurements are in millimetres if nothing else is given.

Steel Tubing System

Our standard tubing system is made of zinc coated carbon steel and is used on 90 % of all Dustcontrol's systems. Heavy wall thickness results in long life even with systems where considerable abrasion is present.

Bend 45°

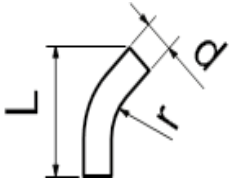

Part No	Desc	Ø	r	l	t
3312	Ø 50	50			
3317	Ø 76	76	160	333	1.5
3009	Ø 76	76	175	78	2.9
3321	Ø 108	108	160	433	2.0
3073	Ø 159	159	375	166.5	4.5

Split pipe

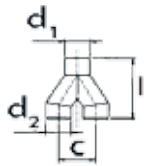

Part No	Desc	Ø ₁	d ₂	c	h	t	m (kg)
3067	Ø 159 /159	159	159	230	458	2.0	6.0

Y-pipe

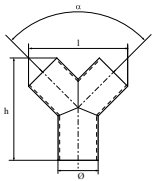

Part No	Desc	Ø	α	l	h	t	m (kg)
3324	Ø 50	50.8	90°	150	175	1.5	0.4
3323	Ø 76	76	90°	190	195	1.5	0.7
3322	Ø 108	108	90°	235	225	2.0	1.4
3066	Ø 159	159	180°	850	485	2.0	6.0

Branch pipe

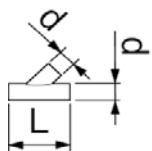

Part No.	Desc.	Ø	α	l	t
3074	Ø 50	51	45°	170	1.5
3003	Ø 76	76	45°	245	1.5
3357	Ø 108	108	45°	267	1.5
3065	Ø 159/76	159/76	30°	390	2.0
3064	Ø 159 /108	159 /108	30°	390	2.0
3063	Ø 159	159	45°	400	2.0
3036	Ø 108/76	108/76	45°	300	1.5

Cone

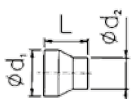

Part No.	Desc.	Ø d ₁	Ø d ₂	l	t	m (kg)
3197	Ø 80 /76	80	76	70	2.0	0,2
3030	Ø 108 /76	108	76	95	1.0	0.15
3078	Ø 76/50	76	50	95	1.0	0.15

For other dimensions: See also polymer-pipe system – Cone.

Steel Tubing System

Our standard tubing system is made of zinc coated carbon steel and is used on 90 % of all Dustcontrol's systems. Heavy wall thickness results in long life even with systems where considerable abrasion is present.

Abrasion resistant bend 90°

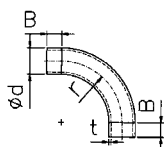

Part No	Desc	\varnothing	r	b	t	m (kg)
3235	\varnothing 76	87	175	50	7.0	5.0
3234	\varnothing 108	121	250	50	5.5	10.6

Joint abrasion resistant bend

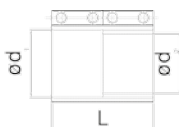

Part No	Desc	$\varnothing d_1$	$\varnothing d_2$	l	m (kg)
3243	\varnothing 76	87	76	130	0.5
3244	\varnothing 108	121	108	130	0.7

Pressure distributor box

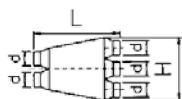

Part No	Desc	$\varnothing d$	b	l	h	m (kg)
3057	3/2	108	110	650	472	10.0
3058	2/2	108	110	550	315	7.0

End cap for steel tubing

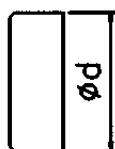

Part No	Desc	$\varnothing d$
3172	\varnothing 50	50.8
3174	\varnothing 76	76
3906	\varnothing 108	108

Joint

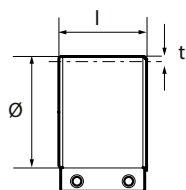

Part No EPDM	Part No NBR	Desc	d	l	t	m (kg)
3077**	3271*	\varnothing 50	50.8	65	4.5	0.2
3007**	3272*	\varnothing 76	76	65	5.0	0.3
3031**	3273*	\varnothing 108	108	65	5.5	0.4
3045**	3274*	\varnothing 159	159	65	6.5	0.5

*) Oil resistant

**) Antistatic

All measurements are in millimetres if nothing else is given.

Stainless Steel Tubing System

Stainless tubing is used with abrasive materials or due to hygienic considerations.

Tubing

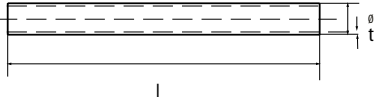

Part No	Desc	Ø	l (m)	t	m (kg/m)
3211	Ø 50	50.8	3	1.0	1.3
3212*	Ø 76	76	3	1.0	1.9
3267	Ø 108	108	3	1.0	5.2
3227	Ø 159	159	3	1.0	4.0

Bend 90°

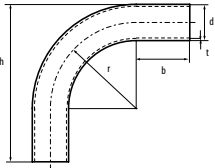

Part No	Desc	Ø	r	b	h	t	m (kg)
3314	Ø 50	50.8	120	75	220	1.5	0.6
3316	Ø 76	76	160	180	313	1.5	1.3
3320	Ø 108	108	160	165	380	2.0	3.0
3262	Ø 159	159	87	90	260	1.0	1.8

Bend 90° extended

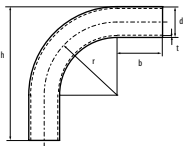

Part No	Desc	Ø	r	b	t	m (kg)
3266	Ø 76	76	460	-	2.0	3.2
3303	Ø 108	108	800	150	2.0	10.0
3314	Ø 150	50	120	220	1.5	0.55

Bend 45°

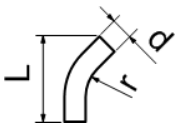

Part No	Desc	Ø	r	l	t
3318	Ø 76	76	160	333	1.5
3315	Ø 108	108	160	433	2.0

Y-tubing

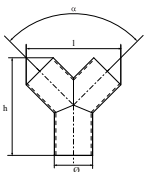

Part No	Desc	Ø	α	l	h	t	m (kg)
3331	Ø 50	50.8	90°	150	175	1.5	0.4
3330	Ø 76	76	90°	190	195	1.5	0.7
3329	Ø 108	108	90°	235	225	2.0	1.4

Stainless Steel Tubing System

Stainless tubing is used with abrasive materials or due to hygienic considerations.

Branch pipe

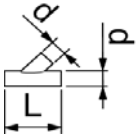

Part No	Desc	$\varnothing d_1$	$\varnothing d_2$	l	α	t
3199	$\varnothing 76/76$	76	76	245	45°	1.5
3358	$\varnothing 108/108$	108	108	267	45°	1.5
3210	$\varnothing 50/50$	50	50	170	45°	1.5

Joint

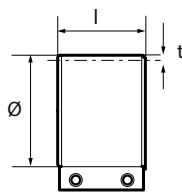

Part No NBR	Desc	d	l	t	m (kg)
307702*	$\varnothing 50$	50.8	65	4.5	0.2
300702*	$\varnothing 76$	76	65	5.0	0.3
303102*	$\varnothing 108$	108	65	5.5	0.4
304502*	$\varnothing 159$	159	65	6.5	0.5

*) Material EPDM/Stainless steel

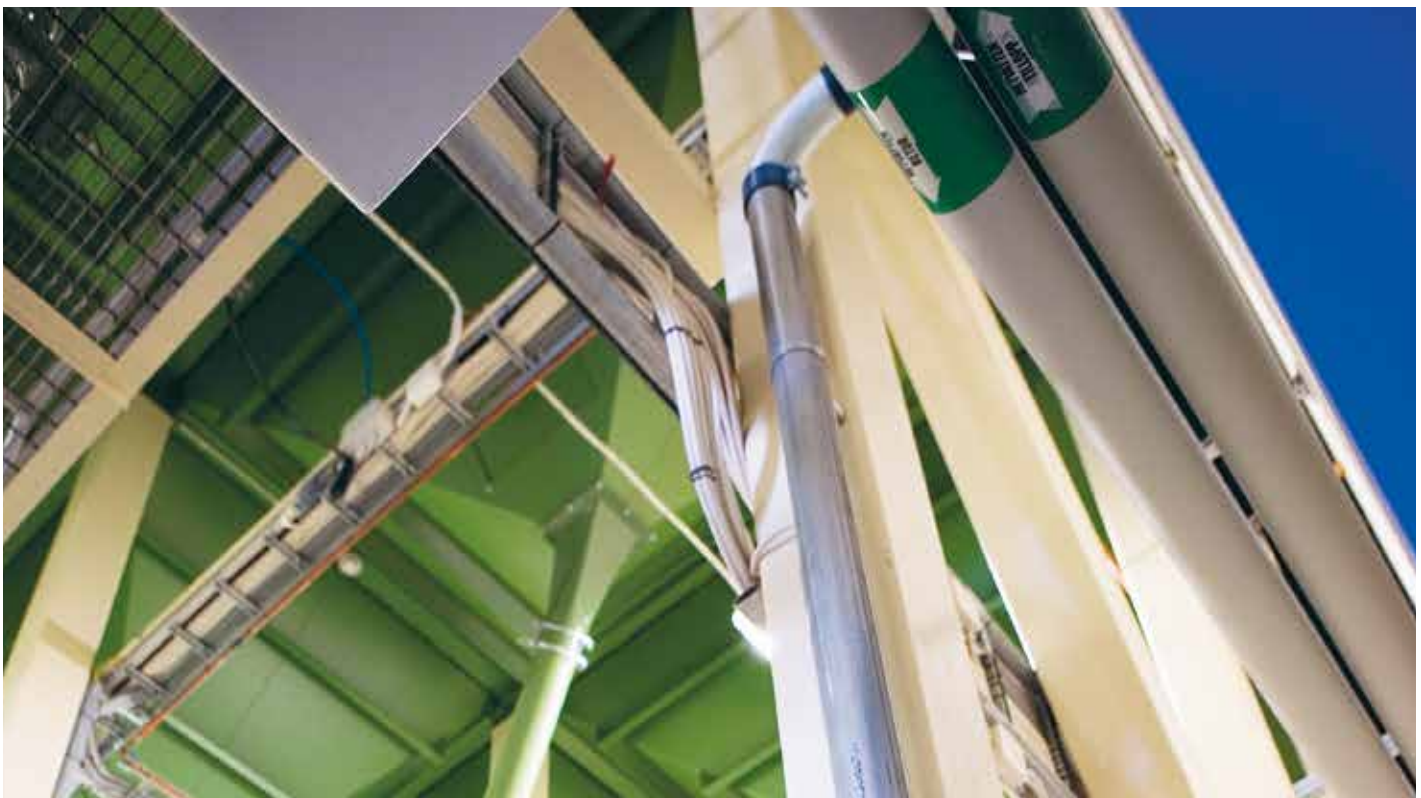

Dustcontrol Steel Tubing System

Polymer Tubing System

An elastomer (EPDM and NBR-rubber) used in bends and, branch pipes and mounting brackets gives to a particularly high wear resistance moderation of the sound level. Dustcontrol's bends are designed with a patented radial ridge to spread the impact area of the material and thereby reducing the wear and minimising the risk of blockage. NBR is especially recommended for use with oil and cutting fluids.

Bend 45° (complete with joints)

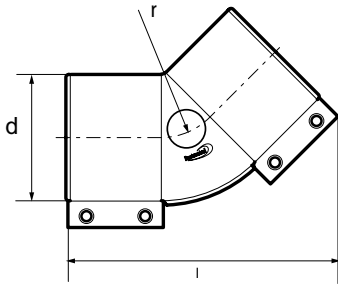

Part No EPDM	Part No NBR	Desc	d	l	r	m (kg/m)
307311**	307312	Ø 50	50.8	150	66	0.5
3343*		Ø 50	50.8	150	66	0.5
300911**	300912	Ø 76	76	170	79	0.6
3344*		Ø 76	76	170	79	0.6
302911**	302912	Ø 108	108	195	94	0.8
3345*		Ø 108	108	195	94	0.8

*) Material EPDM/Stainless steel

***) Antistatic

Cone 90°

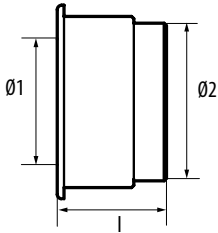

Part No. EPDM	Part No. NBR	Desc.	d ₁	d ₂	l	t
3305**	3325	Ø 76/50	50.8	76	50	0.1
3306**	3326	Ø 108/76	76	108	55	0.3
3307**	3327	Ø 108/100	100	108	35	0.1
3308**	3328	Ø 159/108	108	159	70	0.7

***) Antistatic

Joint

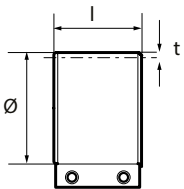

Part No EPDM	Part No NBR	Desc	d	l	t	m (kg)
3077**	3271	Ø 50	50,8	65	4.5	0.2
307702*		Ø 50	50,8	65	4.5	0.2
3007**	3272	Ø 76	76	65	5.0	0.3
300702*		Ø 76	76	65	5.0	0.3
3031**	3273	Ø 108	108	65	5.5	0.4
303102*		Ø 108	108	65	5.5	0.4
3045**	3274	Ø 159	159	65	6.5	0.5
304502*		Ø 159	159	65	6.5	0.5

*) Material EPDM/Stainless steel

***) Antistatic

Polymer Tubing System

An elastomer (EPDM and NBR-rubber) used in bends and, branch pipes and mounting brackets gives to a particularly high wear resistance moderation of the sound level. Dustcontrol's bends are designed with a patented radial ridge to spread the impact area of the material and thereby reducing the wear and minimising the risk of blockage. NBR is especially recommended for use with oil and cutting fluids.

Branch pipe 45° (complete with joints)

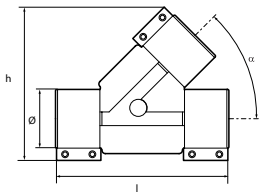

Part No EPDM	Part No NBR	Desc	d	l	h	m (kg)
307411**	307412	Ø 50	50.8	220	150	0.8
3346*		Ø 50	50.8	220	150	0.8
300311**	300312	Ø 76	76	250	200	1.2
3347*		Ø 76	76	250	200	1.2
303511**	303512	Ø 108	108	300	260	1.6
3348*		Ø 108	108	300	260	1.6

*) Material EPDM/Stainless steel

***) Antistatic



Technical data

EDPM

NBR

	EDPM	NBR
Temp °C max/min	140/-60	120/-60
Antistatic	Yes	Yes
Abrasion resistance	Very Good	Good
UV and Ozone resistance	Very Good	Limited
Resistance to fumes	Very Good	Good
Resistance to solvent and oil	Poor	Very good



All measurements are in millimetres if nothing else is given.

Reinforced Spiro Tubing

The reinforced spiro tubing system is used to connect the separator and vacuum pump. It is also used in extraction systems for smoke and light dust.

Spiro Tubing

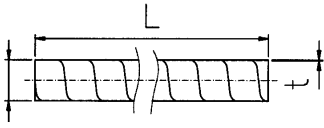

Part No	Desc	d	l	t	m (kg/m)
3013	Ø 100	100	3	0.6	1.8
3123	Ø 125	125	3	0.6	2.2
3042	Ø 160	160	3	0.8	3.7
3095	Ø 200	200	3	0.8	4.7
3090	Ø 250	250	3	0.8	5.9

Bend 90°

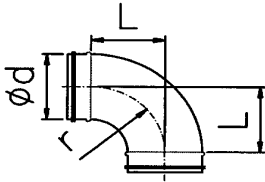

Part No	Desc	d	r	l	m (kg)
3014	Ø 100	100	100	100	0.4
3124	Ø 125	125	125	125	0.6
3043	Ø 160	160	160	160	0.8
3096	Ø 200	200	200	200	1.5
3091	Ø 250	250	250	250	2.4

Bend 45°

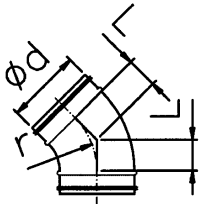

Part No	Desc	d	r	l	m (kg)
3086	Ø 100	100	100	43	0.3
3125	Ø 125	125	125	52	0.4
3089	Ø 160	160	160	66	0.6
3088	Ø 200	200	200	83	0.9
3087	Ø 250	250	250	104	1.3

Bend 30°

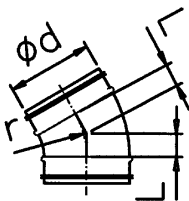

Part No	Desc	d	r	l	m (kg)
3024	Ø 100	100	100	25	0.3
3126	Ø 125	125	125	33	0.3
3025	Ø 160	160	160	43	0.5
3026	Ø 200	200	200	54	0.7
3027	Ø 250	250	250	67	1.4

Reinforced Spiro Tubing

The reinforced spiro tubing system is used to connect the separator and vacuum pump. It is also used in extraction systems for smoke and light dust.

Y-pipe

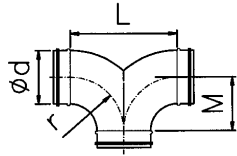

Part No	Desc	d	r	l	M	m (kg)
3127	∅ 125	125	190	375	190	1.5
3128	∅ 160	160	240	480	240	2.5
3129	∅ 200	200	300	600	300	3.8
3130	∅ 250	250	375	750	375	8.6

Branch pipe

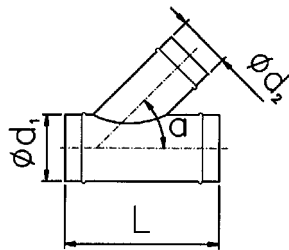

Part No	Desc	d ₁	d ₂	l	α	m (kg)
3131	∅ 100/100	100	100	290	45°	1.3
3132	∅ 125/100	125	100	290	45°	1.4
3148	∅ 125/125	125	125	290	45°	1.6
3133	∅ 160/100	160	100	370	45°	1.6
3134	∅ 160/125	160	125	370	45°	1.9
3149	∅ 160/160	160	160	370	45°	2.5
3135	∅ 200/100	200	100	460	45°	2.2
3136	∅ 200/125	200	125	460	45°	2.3
3137	∅ 200/160	200	160	460	45°	2.9
3150	∅ 200/200	200	200	460	45°	3.5
3138	∅ 250/160	250	160	575	45°	3.4
3139	∅ 250/200	250	200	575	45°	4.0
3151	∅ 250/250	250	250	575	45°	4.6

T-pipe

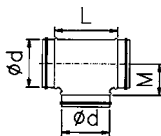

Part No.	Desc.	d	l	M	m (kg)
3051	∅ 160	160	229	105	0.9

Nipple

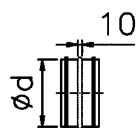

Part No	Desc	d	m (kg)
3015	∅ 100	100	0.1
3144	∅ 125	125	0.2
3044	∅ 160	160	0.2
3099	∅ 200	200	0.3
3094	∅ 250	250	0.5

All measurements are in millimetres if nothing else is given.

Reinforced Spiro Tubing

The reinforced spiro tubing system is used to connect the separator and vacuum pump. It is also used in extraction systems for smoke and light dust.

Cone

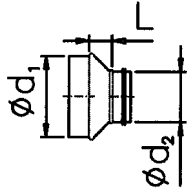

Part No	Desc	d_1	d_2	l	m (kg)
3054	Ø 100 /80	100	80	18	0.2
3141	Ø 125 /100	125	100	22	0.2
3157	Ø 125 /110	125	110	48	0.3
3028	Ø 160 /100	160	100	37	0.3
3142	Ø 160 /125	160	125	26	0.2
3098	Ø 200 /160	200	160	26	0.3
3093	Ø 250 /200	250	200	32	0.6
3122	Ø 250 /160	250	160	53	0.5
3268	Ø 250/ 160	250	160	113	0.6
3269	Ø 250/200	250	200	92	0.6

Socket

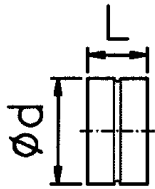

Part No	Desc	d	l	m (kg)
3055	Ø 100	100	90	0.1
3143	Ø 125	125	90	0.2
3056	Ø 160	160	90	0.2
3082	Ø 200	200	90	0.3
3083	Ø 250	250	130	0.5

Clean out cover

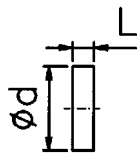

Part No	Desc	d	l	m (kg)
3152	Ø 100	100	40	0.1
3153	Ø 125	125	40	0.1
3154	Ø 160	160	40	0.2
3155	Ø 200	200	40	0.3
3156	Ø 250	250	40	0.5

Reinforced Spiro Tubing

The reinforced spiro tubing system is used to connect the separator and vacuum pump. It is also used in extraction systems for smoke and light dust.

Inline silencer

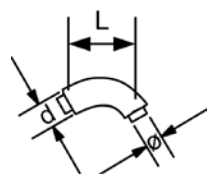
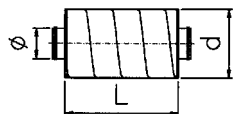

Part No	d_1	d_2	l	m (kg)
3182	160	335	1200	19.8
3183	160	335	600	10.7
3184	160	260	600	6.3
3195	80	180	300	2.2
3350	100	150	250	0.4
4476	100	200	600	4.8
4942	100	200	300	2.6
3228	125	224	300	3.0

Silencers

Absorption dB for mean frequency Hz



Technical data	125	250	500	1k	2k	4k	8k
Part No	dB						
3182	10	18	34	49	53	30	18
3183	8	15	23	31	40	22	16
3184	4	8	21	37	40	22	14
3195	4	8	16	27	34	35	19
3228	2	7	14	21	26	20	12
4476	8	13	25	40	50	40	21
4942	4	8	14	23	27	25	14

All measurements are in millimetres if nothing else is given.

Mounting Hardware

1 Bracket

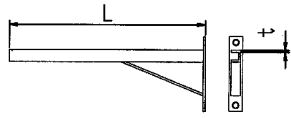

Part No	Desc	L	t	m (kg)
3008	300	300	3	0.85
3037	500	500	3	1.50
3178	1000	1000	3	3.00

2 Clamping band

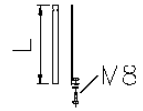

Part No	Desc	d	L	m (kg)
3107	50	51	140	0.10
3021	76	76	210	0.10
3022	110	108	290	0.10
3023	160	159	425	0.15

3 Wall and ceiling attachment

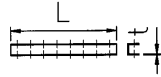

Part No	Desc	L	t	m (kg)
3106	270	270	3	0.40
9622	2000	2000	3	3.00

4 Beam clamp



Part No	Desc	M
3192	M8	M8
3251	M10	M10

5 Threaded rod

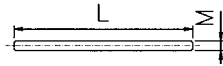

Part No	Desc	L	M	m (kg/m)
3017	HGS8	2000	M8	0.35
3250	M10	1000	M10	0.50

6 Clamping wrapper

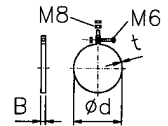

*) 5 pcs

Part No*	d	B	t	m (kg)
3185	50	20	1.25	0.10
3186	76	20	2.0	0.15
3187	110	25	2.0	0.25
3188	160	25	3.0	0.40
3189	200	25	3.0	0.55
3190	250	25	3.0	0.75

7 Tube hanger EPDM, rubber lined

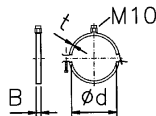

Part No	d	B	t
3245	50	24	1.5
3246	76	24	1.5
3284	101	24	2.0
3247	108	24	1.5
3285	125	24	2.0
3248	160	24	2.0
3249	200	24	3.0
3286	245	30	3.0

8 Pipe strap

Part No	L (m)	b	t	m (kg/m)
3158	25	25	1	0.15

Mounting Hardware

9 Adjusting track

Part No	L	b	h	
3159	300	41	21	
3241	2000	41	21	perforated
3252	3000	41	21	perforated

10 Plate

Part No	a	b	t
3253	52.6	45.5	5.0

10 Spring nut

Part No	M
9601	M8
3289	M10

Two part clamp



Part No	d
3068	Ø 160
3069	Ø 200

Z-attachment

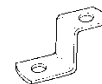

Part No
3011

Tie-wrap, nylon

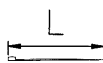

Part No	L
9817	136
9815	360

L-attachment



Part No
3012

Fastener set for mounting

Part No
3198

Duct tape, roll

Part No	L (m)
9076	50

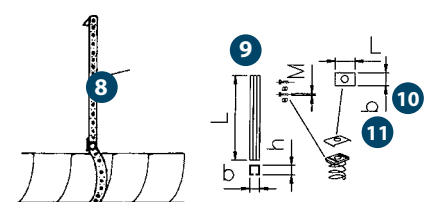
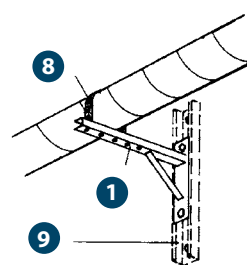
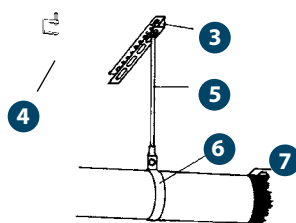
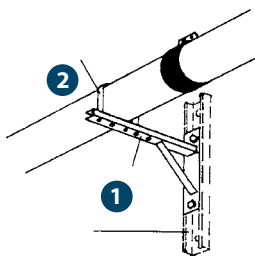

The tubing should be supported on both sides of joints.



Work Station Equipment

An extraction system is sized for only those outlets which are to be used simultaneously. This is in order to maximise efficiency and minimise the size of the central unit. All outlets must have some type of closure, either a valve or shutter. These can be manually actuated, such as flap valves or manual shutter valves, or automatically controlled for actuation only when extraction is required. Swing arms, hose reels and other suspension arrangements help further to increase the flexibility and efficiency of the system.

About Work Station Equipment

An extraction system is sized for only those outlets which are to be used simultaneously. This is in order to maximise efficiency and minimise the size of the central unit. It must be possible to open and close all outlets. This could be via manual shutter and flap valves or automatically on demand. The Flexpipe can be used for fume extraction, high flexibility and small diameter allow it to be placed very close to the fume source.

Overhead suspension arrangements such as swing-arms and hose reels can increase the usefulness of the system, increase ergonomics and minimise potential trip hazards from hose left on the floor.

When large volumes of material are to be introduced into the system, stainless floor funnels can be used from which the material is then extracted.

Manual Flap Valves

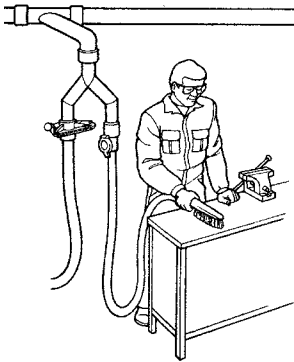

Automatic Flap Valves

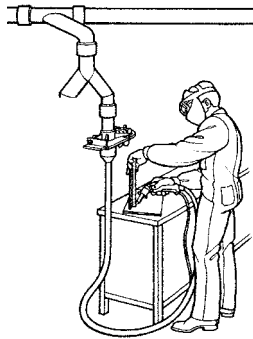

Fume Arms and Suspension Arrangements

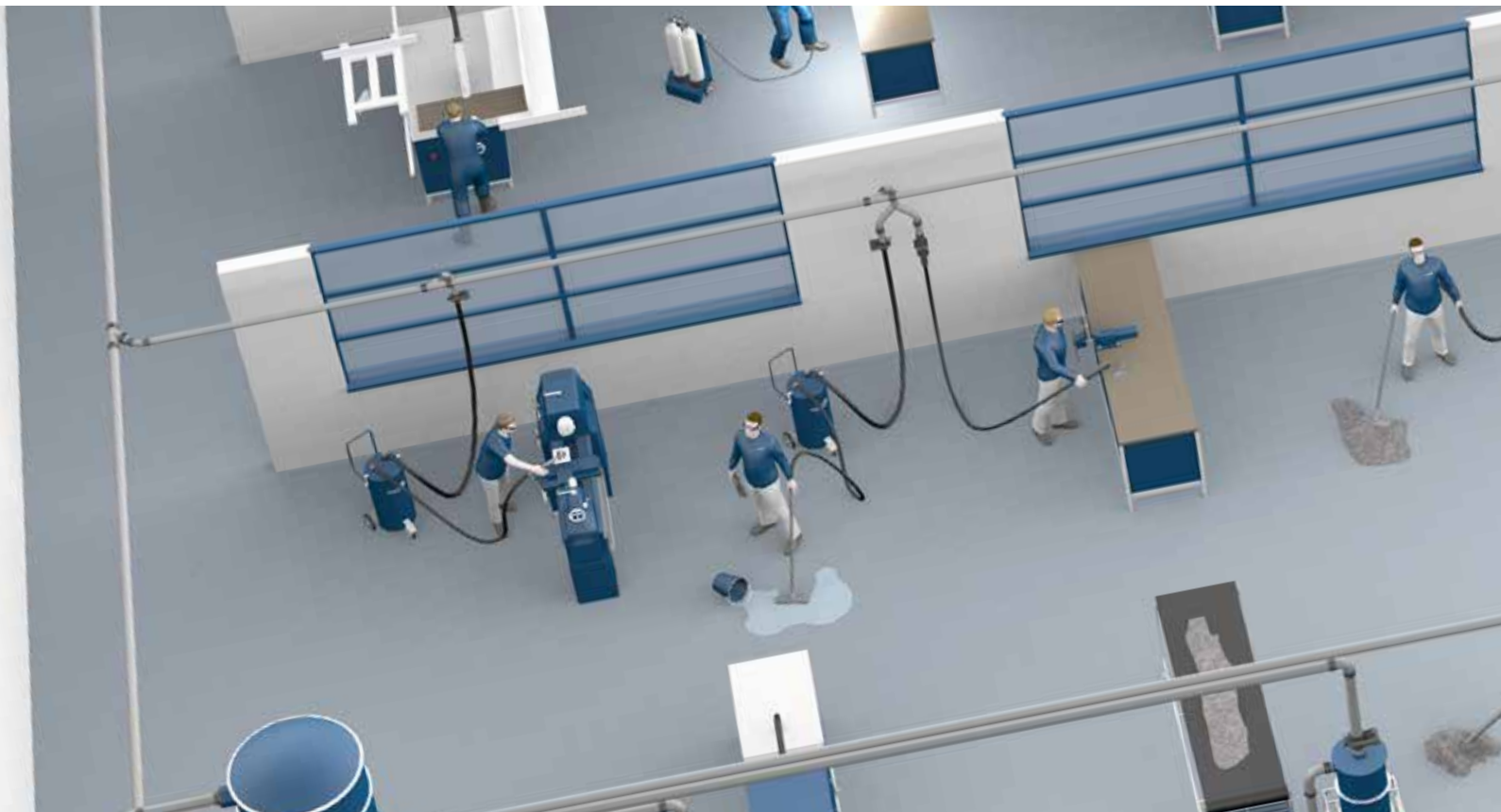
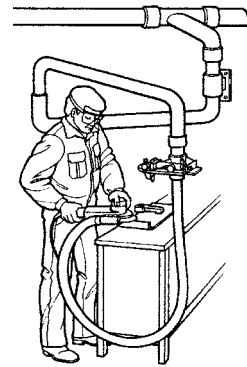

Work Station Equipment

Cutter 108

The Cutter 108 has been developed for cutting soft plastic, paper and cardboard strips and similar materials. The unit is connected to a tubing system and will cut all material in the transport flow into 2–15 cm sized pieces. A rotor with three knives work against one stationary knife.

The knives should be serviced at least twice a year at normal operation 8 hours a day. Depending on amount and type of material, the knives should be sharpened and adjusted every 500–5000 operation hours.

The tubing system before and after the Cutter should consist of straight pipes. Because of safety reasons the inlet and outlet pipes should each be at least one metre long. At installation and service the safety considerations should always be followed.

Part No	Description
7357	Cutter 108
40677	Exchange rotor Cutter 108

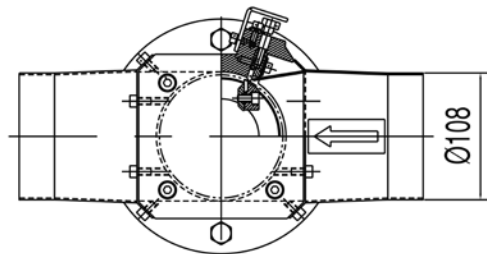
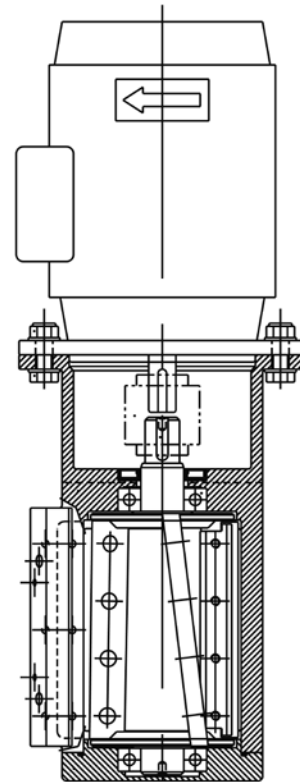

Technical data

	Cutter 108 50 Hz	Cutter 108 60 Hz
Weight	19 kg	19 kg
Inlet/outlet	Ø 108	Ø 108
Motor power	0.75 kW	0.75 kW
Rotation speed	2800 rpm	3400 rpm
Voltage	220-240 / 360-415	254-277 / 440-480

Work Station Equipment

Flap Valves

For ad hoc connection of the suction hose to the tubing system. The spring loaded flap is opened manually and the hose cuff is inserted into the valve body. On systems with on demand start-stop, the flap valve should be equipped with a micro-switch. This will give a start-stop signal for vacuum producer control.



Flap valve 50/76 with micro-switch

Installation Examples

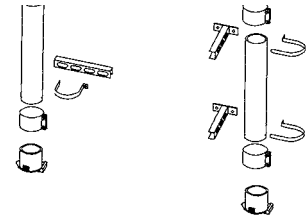

Technical data

d_{max}/D	A	Micro-switch	Part No
38/50 mm	X38	No	3232
38/50 mm	X38	Yes	8454
50/50 mm	X50	No	3070
50/50 mm	X50	Yes	8433
50/76 mm	X50	No	3006
50/76 mm	X50	Yes	8272
76/76 mm	X76	No	3237

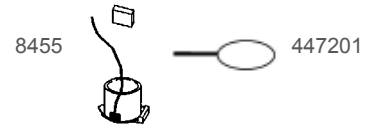

Flap Valves with micro-switch and attached lead

- 8455 Flap valve 50/76 (X50 connection) with micro-switch c/w 3 m lead and terminal box.
- 447201 Handle to open valve.



Work Station Equipment

Wall Outlets

For ad hoc connection of the suction hose. The suction hose must be equipped with a connecting sleeve. Installed in the wall with an installation kit, these provide a finished, flush mounted outlet valve. The valve body with spring loaded flap is installed after the wall is finished.

On systems with on demand start-stop, the wall outlet should be equipped with a micro-switch. This will give a start-stop signal for vacuum producer control.



Wall outlets are available with two finishes; peened aluminum or white enamel.

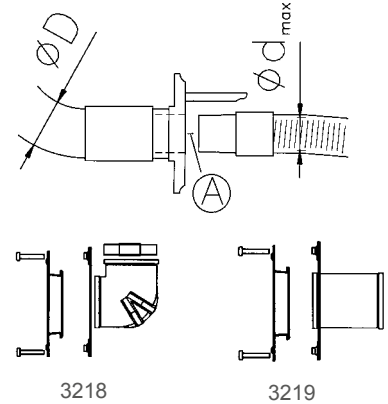

Technical data

d_{max}/D	A	Control	Finish	Part No
38/50 mm	X38	---	peened aluminum	3230
38/50 mm	X38	micro-switch	peened aluminum	8439
38/50 mm	X38	---	white enamel	3231
38/50 mm	X38	micro-switch	white enamel	8453



Accessories (Part No)

- 3218** Installation with 90° joint
- 3219** Installation set with straight joint

Wall Outlets

Dimensions, installation of wall outlets

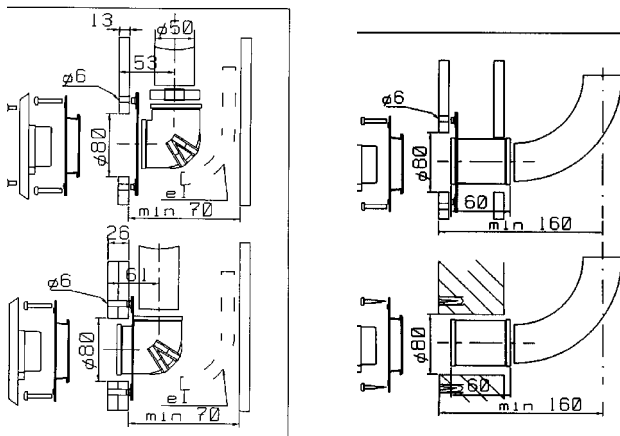

Work Station Equipment

Wall and Floor Outlet, Clean Room

The wall and floor outlet is designed to meet the requirement for clean room applications. The valve body is antistatic and made of pre-stressed polypropylene. The exposed surfaces of the valve are brushed stainless steel.

- The outlet is made for both wall and floor mounting.
- Cover wall mounting plate and spring replacement are possible without removing and replacing the valve body.
- Low profile for mounting even in thin wall partitions.
- Outlet optionally equipped with inductive sensor for auto start-stop.
- Select cleaning accessories Ø 32, 38 or 50 mm.



+ Accessories

Description	Part No. X38/50	Part No. X50/76
Wall mounting plate high	42783	432165
Straight joint	2044	3007
Rubber bend 90°	2043, Ø 50	2180, Ø 76/50
Anchor plate	42264	42950
Cover opener	40201	40201
Connector 62"	42292	-
O-ring 49.5 * 3 shore 50 nitril	40451	-

Part No	Description
322501	Clean room valve without sensor X38/50
84059	Clean room valve with sensor X38/50
3368	Clean room valve without sensor X50/76
3369	Clean room valve with sensor X50/76
40451	O-ring 49,56 * 3 shore 50
42292	Connector Clean room valve 38

Wall mounting

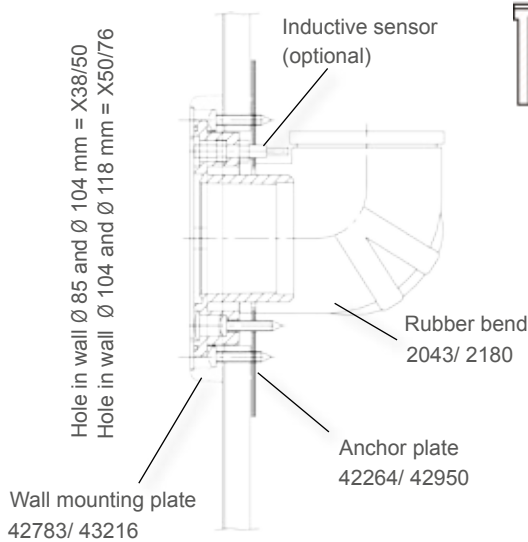

For wooden and raised floors

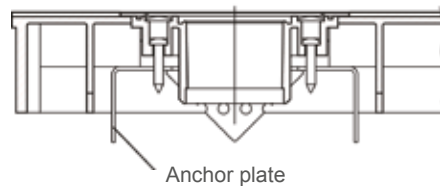

Anchor plate



For poured concrete floor

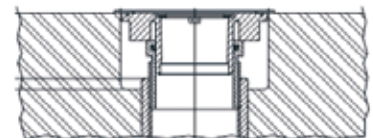
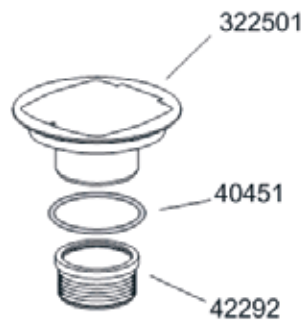

Work Station Equipment

Manual Shutter Valves

Manual shutter valves are used for stationary machine connection or in cases where a permanent hose connection is desired. By pulling the handle the valve opens.

On systems with on demand start-stop, the shutter valve should be equipped with a micro-switch. This will give a start-stop signal for vacuum producer control.



Technical data

D	Control	Part No
Ø 50 mm	---	805201
Ø 50 mm	micro-switch	809101
Ø 76 mm	---	804300
Ø 76 mm	micro-switch	809200
Ø 108 mm	---	808300
Ø 160 mm	---	8254
Ø 200 mm*/	---	8017
Ø 250 mm*/	---	8016

* / Note! Shutter Valve Ø 200 and Ø 250 only for clean air.

Automatic Shutter Valves

The shutter valve has a stainless steel gate actuated by a pneumatic cylinder. For applications on work stations and in the tubing system.

With intermittent start-stop, a pressure switch is installed using a "T" fitting in the compressed air supply. This provides an electrical start-stop signal to the vacuum producer. For valve position sensing, cylinder switches are optionally available. When a shutter needs to be electrically controlled, use an automatic shutter valve, as above, in combination with a solenoid valve as shown here.



Technical data

D	Part No
Ø 50 mm	805308
Ø 76 mm	804408
Ø 108 mm	808404
Ø 108 mm	808408 **/
Ø 160 mm	825404
Ø 200 mm*/	807500
Ø 250 mm*/	807800

Solenoid Valve Part No	V
8026	24 V DC
8088	24 V AC
8054	230 V

* / Note! Shutter Valve Ø 200 and Ø 250 only for clean air and to single step fans (10 kPa max).
 **/ For demanding environments.

Electric Shutter Valves

Electrically driven shutter valves can be built for special applications. Note that the speed of the gate will be much slower for an electrical shutter than for a standard shutter.



Technical data

Description	V	Part No
76 EL	230	804411
108 EL	230	808407
160 EL	230	825407

Work Station Equipment

Accessories Shutter Valve Auto and Electric

+ Accessories Shutter Valve Auto and Electric (Part No)

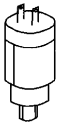

8047 Pressure Switch
 Installed on pneumatic cylinders to supply electrical signals for start-stop control of vacuum producer. Gives signal when valve is opened.

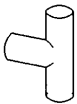

8152 T Fitting
 Required for installation of the 8047 Pressure Switch.

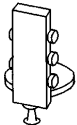

8040 Manual Switch
 For manual actuation of auto shutters.

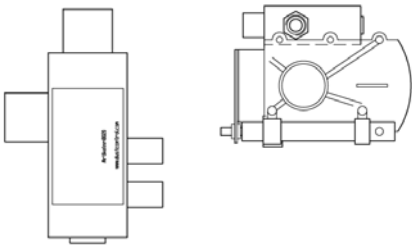

8020 Flow Valve
 Actuates an auto shutter when installed in compressed air supply to a pneumatic tool. Controls on demand extraction. 8020 should be supported by compressed air according to PNEUROP 6611 CLASS 3. CA supply must be clean and dry, 90 PSI recommended.

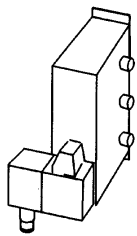

8026 Solenoid 24 V DC
8054 Solenoid 230 V AC
8088 Solenoid 24 V AC
 A separate solenoid is used for example, on stationary machines and in connection with a manual switch. The solenoid is connected pneumatically to the auto shutter. Generally installed in control panel of the subject machine.

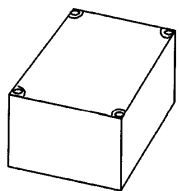

8196 Auto-start 230 V AC
 Auto-start control is used for on demand extraction for electric tools (max 8 amps on subject tool). The auto-start current sensor closes a relay to give solenoid actuation of an auto shutter.



Work Station Equipment

+ Accessories Shutter Valve Auto and Electric (Part No)

8168 Welding Auto-start with current sensor Used for automatic control of extraction in induction welding applications. Striking an arc will cause the current sensor to close a relay. In turn the relay causes solenoid actuation of an auto shutter. This control must be supplied with 24 V AC, 0,5 A.

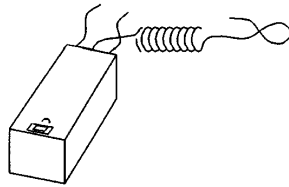

8029 Transformer 230/24 V AC 4 A Supply transformer for 8168 Welding Auto-start.

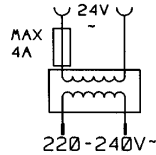

Vacuum Relief Valve

The vacuum relief valve bleeds in air at the pre-set relief level and can be installed at the outermost point on a tubing system. The valve will introduce transport air into the system when the pressure in the system exceeds the setting (12-29 kPa) of the vacuum relief valve.

Part No	Description
8253	Vacuum Relief Valve $\phi 50$
8001	Vacuum Relief Valve $\phi 76$
8002	Vacuum Relief Valve $\phi 108$

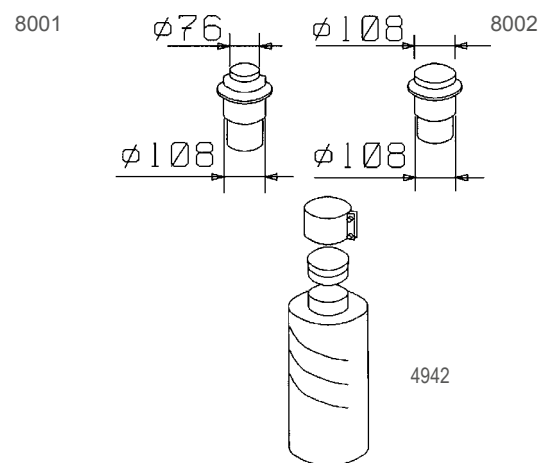

+ Accessories (Part No)

- 4942** Silencer $\phi 100$ 300/200
- 42005** Tool Cage for vacuum valve

Work Station Equipment

Fume Extraction Arm

Extraction arm for welding fume etc. This articulated arm is easily adjusted to the correct working position. The hood is equipped with a 24 V 50 W halogen work lamp and dual switches for lamp and Electric Shutter Valve control. The 76 mm Extraction arm should always be installed with 1 m of 76 mm hose between the arm and tubing system.

Part No 590102 Ø 76

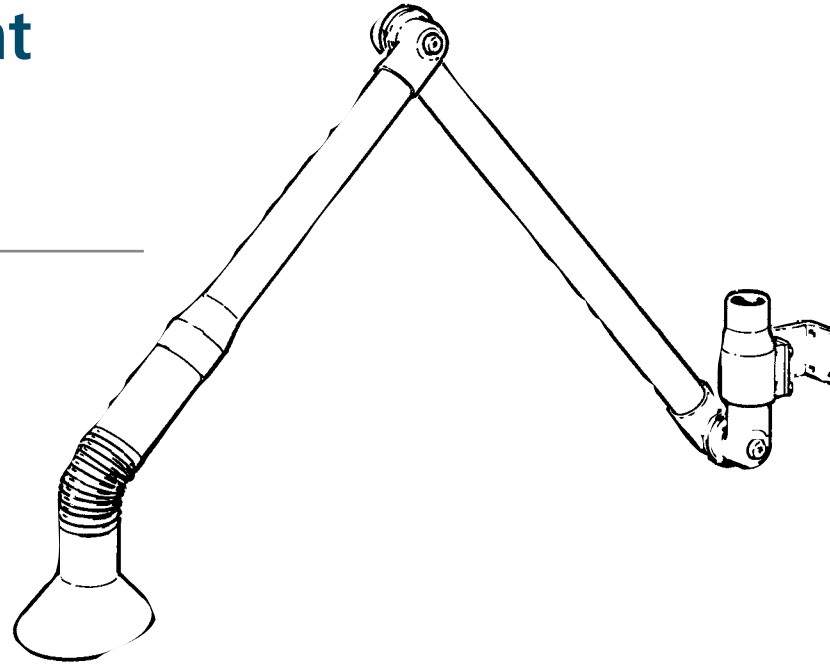

Accessories (Part No)

804411 Shutter Valve 76 Electric 230 V



Technical data

Description	Q_{nom}	Δp_{nom}
Ø 76	400 m ³ /h	3 kPa

In high pressure systems, the extraction arms may require a restrictive plate to compensate pressure for suitable air flow.



Work Station Equipment

Flexpipe

Dustcontrol's Flexpipe is a type of extraction arm for source extraction of welding fume, chemical vapors, wood, dust, etc. The flexpipe is a flexible hose that can be placed in practically any orientation desired.

The diameter of the Flexpipe is small and it can be used very close to the source without disturbing work. The extraction is very effective.

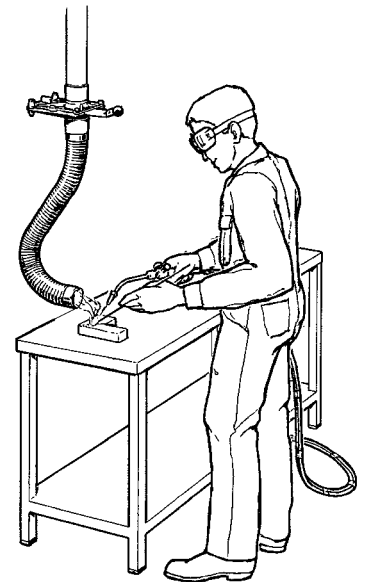

Mounting alternatives

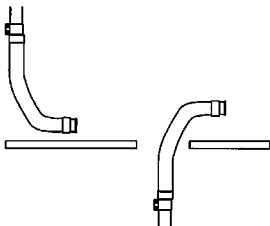

Technical data

Part No	7330	7308	7331	7332
Inner Diameter	Ø 50	Ø 50	Ø 76	Ø 76
Tubing System				
Connection	joint Ø 50	joint Ø 50	joint Ø 76	joint Ø 76
Length	700 mm	1 m	700 mm	1 m
Air Flow	80–200 m ³ /h	80–200 m ³ /h	200–450 m ³ /h	200–450 m ³ /h

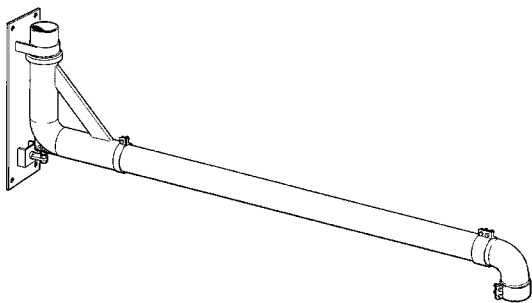

Swingarm for Flexpipe

The Flexpipe reach can be increased with a swingarm installation. The swingarm length is easily adjusted by either cutting the horizontal tube or by replacing it with a longer tube from the standard tubing system, max. 3 m for Ø 50 and max. 4 m for Ø 76. The swingarm may be equipped with suction hose but should not be loaded with anymore than the weight of the hose itself.

Dimensions

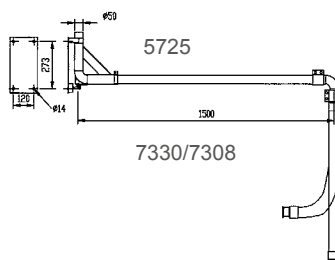
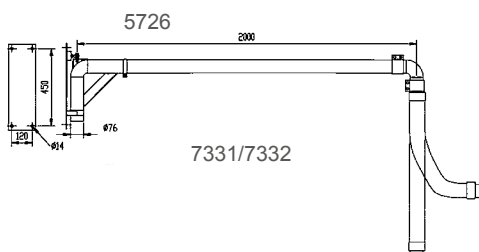

Part No	Description
5725	Ø 50
5726	Ø 76

Work Station Equipment

Swingarms

Swingarms are used to increase the working envelope without increasing hose lengths. Optionally, tools can be suspended from the swingarm.

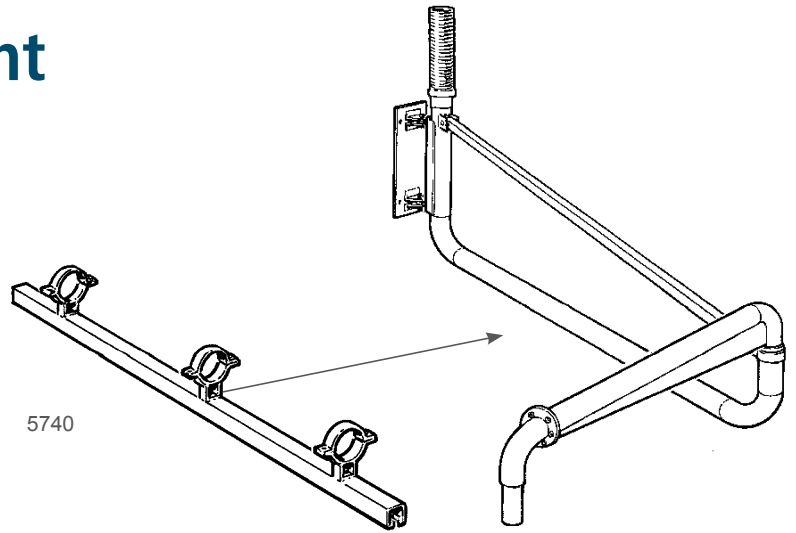

Part No	Description
5720	2.5 m
5721	3.5 m
5722	4.5 m
5723	6 m
5724	8 m

Dimensions

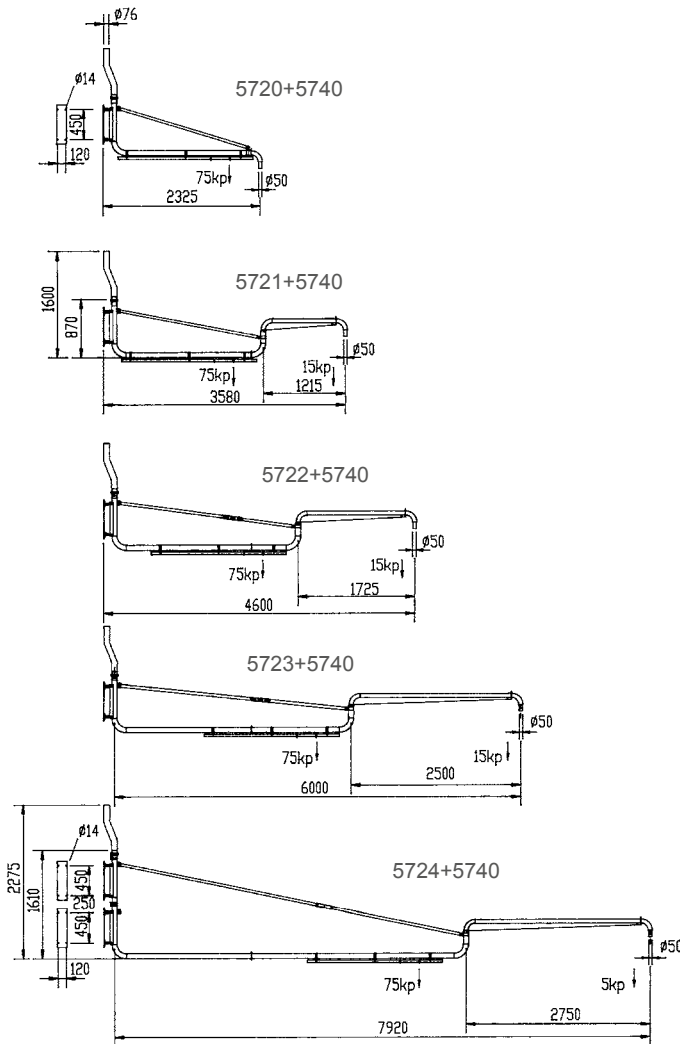

Accessories (Part No)

5740 Linear Suspension Track
The suspension track is installed on the inner link of the swingarm.

Mounting alternatives

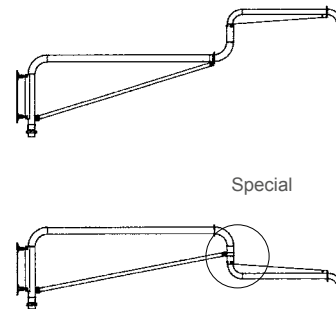

Work Station Equipment

Hose Reels

The DC Hose Reel 38/50 is the second generation of our spring operated hose reels and is a complete redesign. Due to its smooth operation the DC Hose Reel 38/50 is very user friendly. Simply pull down the hose and it locks in the desired position. Pull it again and the hose rewinds to the starting position.

The sealed drum guarantees smooth operation and protects the hose from every day wear and tear. The DC Hose Reel 38/50 can be installed either on the ceiling (part no 7503, 7506) or on the wall (part no 7504, 7505).

The DC Hose Reel 38/50 is more sturdy, has a long reach and a wide radius of action due to the extended hose. The sealed drum is not pivotal and mounted in a fixed position instead.



7505 Hose Reel

Part No Description

7503	Hose Reel 38 mm, complete, ceiling
7504	Hose Reel 38 mm, complete, wall
7505	Hose Reel 50 mm, complete, wall
7506	Hose Reel 50 mm, complete, ceiling

7504/7505 Wall

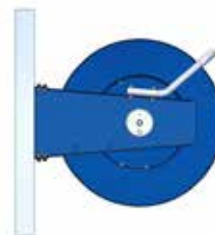

Hose guide installed outwards.

7503/7506 Ceiling



Hose guide installed upwards.



Accessories (Part No)

4942	Silencer Ø 100 300/200
42005	Tool Cage for vaccumvalve
7507	Wall Bracket Hose Reel, turnable



Technical data

Dimension	38 mm	50 mm
Hose part no /length, antistatic	2013/8 m/26 ft., Ø 50 mm/2 in. + 2012/2 m/6 ft., Ø 38mm/1.5 in.	2013/10 m Ø 50 mm/2 in.
Connection diameter	Ø 50 mm/2 in.	Ø 50 mm/2 in.
Compressed air supply	min 5 bar (75 psi)	min 5 bar (75 psi)
Recommended air flow	100-150 m³/h	150-320 m³/h

For specific information about the hoses – see Material properties hoses.

Work Station Equipment

Tool Holder with Flow Control

Dustcontrol's tool holder with flow control has been developed for hand-held tools that are connected to a source extraction system. The suction flow shuts automatically when the user puts the tool into the holder and opens when it is removed. This function reduces the energy consumption while making the working process more efficient. In its standard configuration, the tool holder can be used for brush nozzles and grinding tools with discs with a diameter up to 180 mm.



Technical data

Dimensions (HxWxL) 210 x 210 x 210 mm/8,3 x 8,3x 8,3 in.

Weight 3 kg / 7 lb

Connection Ø Pneumatic tubing 6 mm / 1/4 in.

A



A Holder for hand-held tools

B

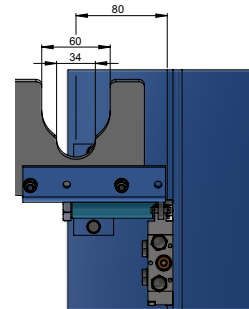

B Spring-loaded 5/2-valve (controls the shutter valve within the extraction system)

Part No 432193 Tool Holder

FilterSaver

The FilterSaver distributes the jet pulse evenly over the whole filter area, facilitating better removal of dust stuck to the filter. By removing more dust the pressure drop over the filter is reduced. A reduced pressure drop also increases the service life of the filter, reduces the energy consumption and increases the suction of the system.

Part No	Description
43925	FilterSaver for filter part no 4284
43926	FilterSaver for filter for part no 4292



Filter cleaning with FilterSaver

Control Systems

Motor starters and System Control Panels control the operation of the system, both operation of the vacuum producers and cleaning of the filter. A variety of other control functions can be installed as required. Even with a rather basic control system, intelligent features can be included to clear coarse material in the main tubing runs or control vacuum production and therefore energy consumption according to actual requirements.

About Control Systems

The control system is used for the starting and stopping of the vacuum producer, turbo pump or high pressure fan. They also control filter cleaning and give condition indications. In the system control cabinets, additional functions can be built in by selecting options.

All Control systems must be installed by a certified electrician. The control panels conform to electrical protection class IP 54 (IC529). Manufacturing standards conform to EN 60204 (IEC204-1), VDE0113A2/381, DIN 57113A2.

Main fuses and working disconnects are not included in the control cabinets.

System Control Cabinets



System control cabinets are always delivered with

- Main switch
- All condition indications and manoeuvres on display
- PLC-control
- Motor circuit breaker
- Function for start and stop of pump/fan with soft start
- Pulse control for filter cleaning
- Start from external signal, prepared for intermittent run (10 min stop delay)
- Manual start on display
- Timers for filter cleaning and intermittent run can be altered on display
- Connection of thermal protection (pumps of 11 kW and more)
- Condition indications and alarms on display
- Start on demand for lag pumps/fans (panels for 2 and 3 vacuum producers)
- Signal for shutter valve shutting at start (fans)
- 5.5 kW and above



Dimensions (base configurations)

Measure	Height	Width	Depth
1 pump/fan 2.2–11 kW	600	380	210
1 pump/fan 15–22 kW	700	500	250
1 pump/fan 30–37 kW	800	600	250
2 pump/fan 2.2–11 kW	800	600	250
2 pump/fan 15–22 kW	760	760	300
2 pump/fan 30–37 kW	1000	800	300
3 pump/fan 2.2–11 kW	1000	800	300
3 pump/fan 15–22 kW	1200	800	300
3 pump/fan 30–37 kW	1200	1000	300

Control Systems

DC Green System

Dustcontrol's patented DC Green System is a system for the control of vacuum producers that helps to save energy. The DC Green System together with our vacuum producers (turbo pumps), can offer you an energy saving with existing or new Dustcontrol vacuum producers of between 40 and 90 percent.

Depending on the number of open outlets, the rpm of the vacuum producer is optimised by the DC Green System, generating just as much vacuum as needed. By using an on-demand control with a frequency converter, the maximum performance is also increased compared to a normal system. When no outlets are open, the vacuum producer automatically switches to a saving mode. This eliminates the need for electrical microswitches at each work station.

Depending on individual cases and the current market price of electricity; payback time for the purchase of the DC Green System is generally between 1-5 years. In summary, lower energy consumption contributes to economic savings, less environmental impact and an increased life span of the equipment.

Your Dustcontrol representative can calculate the estimated saving in your case.



- ✓ Lower power consumption
- ✓ No micro-switches
- ✓ Higher peak performance
- ✓ Optimum suction performance at all times
- ✓ Increased lifetime of the vacuum system
- ✓ Efficient filter cleaning during running
- ✓ Decreased sound level



Control Systems

DC Green System

Why not reduce your carbon footprint and at the same time cut your costs by choosing the DC Green System™

Traditional Vacuum System

Part of total working hours

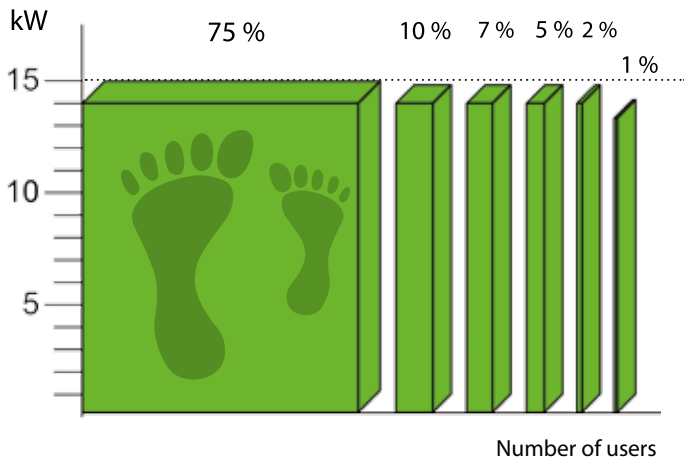

With a 15 kW vacuum producer and a traditional vacuum system, the rpm is almost constant, no matter if the entire plant is using the system or if one employee is using the system.

Dustcontrol Green System™

Part of total working hours

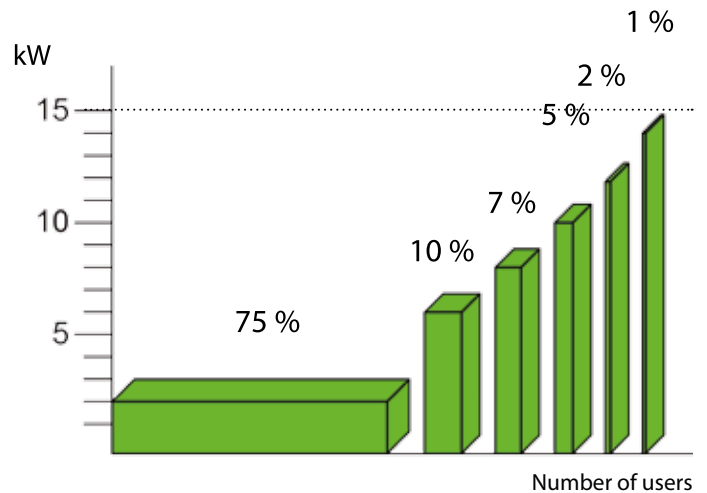

With a 15 kW vacuum producer with DC Green System the rpm and energy use is matched with the number of people using the system at the same time.

Visit www.dustcontrol.com search **DC Green System** – for further info regarding your energy savings.

DC Green System

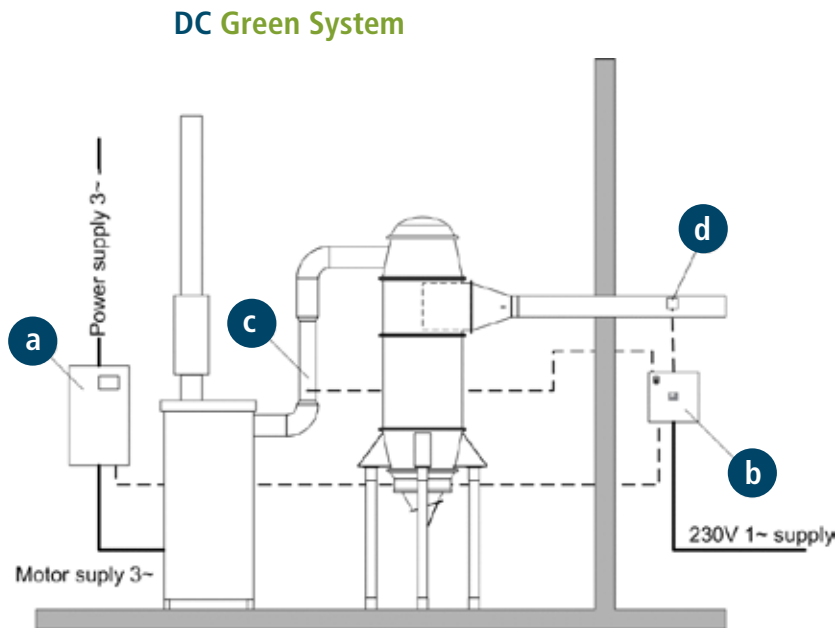

DC Green System = Package consisting of

- a** 3 phase frequency converter for the pump
- b** 230V control panel with operator's display, PLC and necessary control connections
- c** flow sensor
- d** pressure sensor

Your Energy Savings with the DC Green System

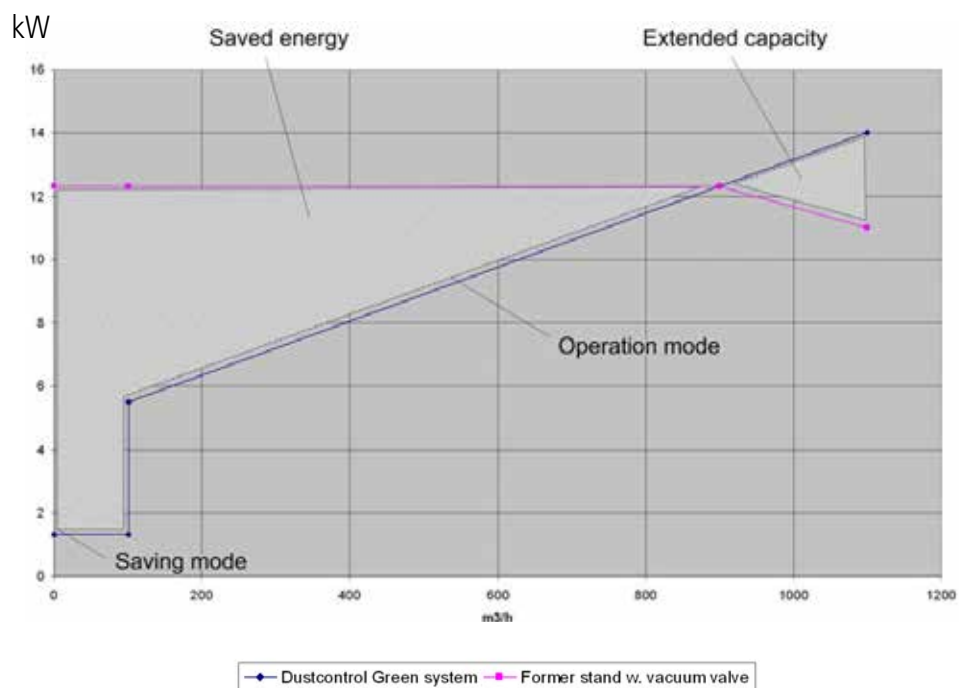



Dustcontrol

Dustcontrol
www.dustcontrol.com



Mobile Dust Extractors

As a true professional, you place high requirements on your equipment. Dustcontrol have been involved with air cleaning for more than 40 years, and we supply dust extractors and air cleaners for all types of jobs. No matter what you choose, you can be sure of getting a truly professional machine that is built with your work and your health in mind.



Dustcontrol

DF 200

Dustcontrol

MAX MIN

POWER

FILTER

AirCube 500

Dustcontrol CE
Modello: AirCube 500
Potenza: 1000 W
Suggerimento di aspirazione: 1000 W
Suggerimento di aspirazione: 1000 W
Suggerimento di aspirazione: 1000 W
Suggerimento di aspirazione: 1000 W

Dust Extractor selection advice

1 Capacity/Weight

Check the capacity of the unit in relation to its weight and portability. The motor power does not determine capacity, but rather airflow and vacuum generation (cfm/m³/h x inwg/kPa) available to the operator (normally at 40–80 inwg/10–20 kPa). (The lower the unit weight for comparable capacity, the easier the unit will be to move and use.)

2 Material Handling

Dust, bulky materials, chips and strips can be collected and transported with vacuum. When the material volume is large, efficient handling saves time and money. Ergonomic handling of the unit and the collected material is also important. The system design should minimise the possibility of dust contamination during collection bag and filter changes. The dust collected in the system should be contained during these activities.

3 Sound Level

Even in environments where the sound level is not considered harmful, remember that each additional source increases the overall level. Compare the sound level rating of the unit with measurements from the subject environment. To have a zero net gain, the sound level of the unit should be at least 5 dB(A) below the ambient level.

4 Filtration

Choose the filtration system so the unit does not lose capacity after some minutes of use. Dustcontrol dust extractors separate the dust in three inter-related steps:

1. Separation of coarse material in the cyclone

– A good quality cyclone has the right characteristics relative to the capacity of the vacuum producer. Generally, the longer the cyclone, the better.

2. Fine filtration – The fine filter protects the HEPA filter and has a lower replacement cost. To extend the life of the HEPA filter, Dustcontrol recommends that you replace the fine filter frequently. A conical pleated filter cartridge achieves the highest air to cloth ratio of any filter design on the market. The machine should also have a filter condition indicator and an effective filter cleaning system. For some applications, you may require a PTFE-coated fine filter.

3. HEPA filtration – Do not compromise your health, very close to 100 % filter efficiency is achievable. When the air is exhausted back into the working environment, a HEPA H13 filter is highly recommended. If elimination of hazardous dust is the target, then why release respirable dust back into the working environment?

5 Suction Casings

Dustcontrol developed the source extraction concept 40 years ago! Source extraction is the most effective method for maintaining a clean working environment. A Dustcontrol suction casing captures dust or fume directly at the point of generation. Practically all popular hand power tools can be equipped with a suction casing. Recently, some machine manufacturers have integrated their own suction casings.

With Dustcontrol's connecting sleeves, part nos. 2109 (1"/25mm), 2132 (1.25"/32mm) or 2114 (1.5"/38mm), they can connect to Dustcontrol dust extractors. Enjoy dust-free operation of your hand held tools by upgrading to a Dustcontrol dust extractor.

6 Applications

Concrete Dust

Tough applications, such as concrete grinding, demand a lot from a dust extractor and filter. Since there are high volumes of very fine particulate, you may need a PTFE filter. A pre-separator is also recommended for large floor grinding machines. The DC 3900 Twin and the DC 5900 with PTFE filters are the most suitable dust extractors for this type of work.

Fluids

All Dustcontrol's dust extractors can be used for vacuuming non-flammable liquids in small quantities. However, Dustcontrol also offers a dedicated liquid extractor for larger quantities such as concrete coring.

Metal Chip/Swarf

A steel container is preferred when vacuuming sharp items such as metal chips. All dust extractors can be ordered with a steel container.

Hazardous Materials

Special precautions must be taken when dealing with hazardous materials such as silica dust and PCB (health hazardous chemicals). First, a machine with at least a HEPA H13 filter is a must. Second, suction casings are needed for your tools to avoid hazardous dust becoming airborne. Third, an additional air-cleaner is required to clean the air in your working environment. Finally, protect yourself with mask, eye-wear, and protective clothing.

Potentially Explosive Environments – ATEX

Not only liquids and gases can be explosive. Also very fine dust particles mixed with air can be explosive. A tiny spark from a static discharge or a mechanical spark can set off an explosion inside a dust extractor. European Standard Directive 2014/34/EU stipulates certain arrangements, configurations and measures for design of a dust extraction or vacuum cleaning system intended for use with an explosive dust. Dustcontrol can design your system for compliance and foremost, safe operation with respect to these engineering guidelines.

7 The Right Size

Two things determine the most suitable dust extractor required for a given application:

First, the size of the suction casing/nozzle, combined with the type of operation, determines the required airflow. In turn this influences the choice of a suitable dust extractor, taking into account the filter area and the dimension of the inlet.

Second, the longer the hose and tubing-runs, the greater the pressure drop in the system will be. Greater pressure generation is required from the dust extractor when handling large quantities of material (heavy cleaning, suction lance etc.)

Classification of Dust Extractors and HEPA Filters

Dust extractors are used to improve the working environment, and to reduce levels of hazardous dust in the air to a minimum. This places great demands on the ability of the dust extractor to separate fine dust. We use a fine filter in our mobile dust extractors, which separates most of the dust. But in order to capture close to 100% of the finest and most dangerous particles, we always complete the design with a HEPA H13 filter.

Here at Dustcontrol, we use conical pleated filters in all of our dust extraction units. A pleated filter has a very large area in relation to its physical size. The dust extractors can therefore be compact in relation to the large filter area they contain.

Only original Dustcontrol filters are tested and approved for use in our machines. The use of other types of filters could lead to the leaking of hazardous dust and/or machine breakdown. Dustcontrol's warranty only applies to machines equipped with original Dustcontrol spare parts. The filters are certified in accordance with current European requirements for dust extraction. This ensures that, with correct handling, optimum filtration will be achieved. Follow the instructions when handling filters, so that they can be replaced without exposure to hazardous dust.

To ensure that the filters comply with the requirements of relevant regulations for health and safety at work, a number of different testing standards are used. These are described below:

Test methods

The test methods used in current standards for dust extractors and filters are always based on particle counting. By injecting particles before the filter and by using a particle counter to determine the concentration before and after the filter, the penetration can be calculated (a penetration of 0.1% is equal to a degree of separation of 99.9%). The test is carried out in several

stages by individually examining the filter media, the complete filter cartridge and, in some cases, also the complete unit.

HEPA filters — High Efficiency Particulate Air Filters

When classifying HEPA filters, Dustcontrol uses the strict HEPA standard (EN 1822-1). It is divided into different levels (E10 to H14) depending on filtration efficiency. Dustcontrol applies level H13, which can separate up to 99.95% of the particles between 0.15 and 0.30 µm in size. This particle size is used because it is the hardest to separate – both larger and smaller particles are easier to capture in a filter.

Dust extractors

In IEC-60335-2-69 (EN-60335-2-69), the standard for testing wet and dry extractors, dust extractors are classified into three categories – **L for low, M for medium and H for high** – where the H category is the most stringent. (Please note: do not confuse this “H” with that in HEPA H13). The category required for a specific application is decided on the basis of the permitted maximum concentration for that type of dust (MAK) in the working environment or by local regulations.

The test according to EN-60335-2-69 comprises two parts:

1. A test of the filter system – in our case, a fine filter and a HEPA H13 filter. To achieve category H, a degree of separation of 99.995% is required, where 90% of the test particles must be smaller than 1.0 µm. Our fine filters comply with category M, and our HEPA H13 filters with category H.



2. A test of the “assembled unit” – in our case, a complete dust extractor. Here, 99.995% efficiency is also required, however 10% of the particles must be smaller than 1.0 µm, 22% smaller than 2.0 µm, and 75% smaller than 5.0 µm.



The filter systems in all Dustcontrol dust extractors are built to comply with the stringent IEC machine classification H.



Classification of our dust extractors

NAME	CLASSIFICATION	STANDARD	EFFICIENCY	PARTICLE SIZE	EXAMPLE	MAK (Maximum Workplace Concentration)
	L= 		> 99%			> 1.0 mg/m ³
	M= 		> 99,9%			> 0.1 mg/m ³
IEC* standard	H= 	IEC 60335-2-69	>99.995%	0.1 - 5.0 µm**	H=99.995%	< 0.1 mg/m ³ and carcinogenic substances including asbestos

* IEC: International Electrotechnical Commission ** Part 1: 90 % < 1.0 µm Part 2: 10 % < 1.0 µm
22 % < 2.0 µm
75 % < 5.0 µm

Classification of our HEPA filters

NAME	CLASSIFICATION	STANDARD	EFFICIENCY	PARTICLE SIZE	EXAMPLE
	E10		85%	MPPS** between 0.15–0.30 µm	
	E11		95%		
	E12		99.5%		
HEPA*	H13	EN 1822-1	99.95%		HEPA H13 = 99.95 %

* High Efficiency Particle Air filter, ** Most Penetrating Particle Size



Single-Phase Dust Extractors

DC 1800



This machine is particularly suitable for general cleaning and source extraction from handheld power tools (with suction casings up to \varnothing 125mm/5") and small table saws.

The DC 1800 is equipped with a container. A plastic bag can be used inside the container to facilitate the emptying of dust and other material.

Part No DC 1800 50/60 Hz

101800	230V /50 Hz, EU
101801	230V /50 Hz Auto start*, EU
101808	230V /50 Hz, CH
101810	115V /50 Hz, UK
101820	230V /50 Hz, UK
101830	115V /60 Hz, US/CAN

*) DC 1800 Autostart. Plug the handheld power tool into the power socket on the unit. Set the selector switch to the AUTO position. The dust extractor will start automatically when the power tool is started.



Supplied with (Part No)

Suction hose (\varnothing 38mm), 5 m (2111)
 Suction hose, antistatic (\varnothing 38/1.5"), 5 m/16 ft (2012)
 UK/US/CAN models
 Connecting sleeve (2115)
 Coupling socket (2108)
 Floor nozzle B370/W17" (7235)
 Suction pipe, steel, \varnothing 38mm/1.5" (7257)
 Plastic bag (42291)
 Bag support frame (42369)
 Fine filter, cellulose (42029)
 HEPA H13 filter (42027)



Technical data

H x W x L (cm/inch)	74x38x38 /29"x15"x15"
Weight	14 kg /31 lbs
Hose length	5 m /16 ft \varnothing 38 mm /1.5"
Container	20 l /5.2 US gal
Flow at open inlet	190 m ³ /h /114cfm
Negative pressure, max 115/230V	21/24 kPa / 84/96 inwg
Power consumption 115/230V	1285/1340 W
Sound level	68 dB(A)

DC 1800 XL

The DC 1800 XL is especially suited for parquet grinding and other working operations that produce light dust. Suitable for general cleaning and source extraction from handheld power tools (with up to 5" suction casings) and small table saws. It is slim, lightweight and ideal for those that need a highly portable machine that is powerful enough for source extraction. Equipped with a steel container and a plastic bag used inside the container.

Part No DC 1800 XL

101880	XL, 230V /50 Hz, EU
101881	XL, 230V /50 Hz, Auto start*, EU
101884	XL, 230V /50 Hz, UK
101885	XL, 115V /60 Hz, USA
101887	XL, 115V /60 Hz, CAN
101888	XL, 230V /50 Hz, CH



Technical data

H x W x L (cm/inch)	116x38x38 /46"x15"x15"
Weight	19 kg /42 lbs
Hose length	5 m /16 ft \varnothing 38 mm /1.5"
Container	55 l /14,3 US gal
Flow at open inlet	190 m ³ /h /114cfm
Negative pressure, max 115/230V	21/24 kPa / 84/96 inwg
Power consumption 115/230V	1285/1340 W
Sound level	68 dB(A)

Single-Phase Dust Extractors

DC 2900c



The DC 2900c is our most popular dust extractor. It is suitable for vacuum cleaning and source extraction from handheld power tools (with suction casings up to Ø 125mm/5") and small table saws. The DC 2900c has a sturdy steel chassis with large wheels, but is still light and portable.

Part No DC 2900c, 50/60 Hz

120000	230V /50 Hz, EU
120003	230V /50 Hz, UK
120008	230V /50 Hz, CH
120013	115V /50 Hz, UK
120015	115V /60 Hz, US/CAN
120100	230V /50 Hz, Auto start*, EU
120103	230V /50 Hz, Auto start, UK*

*) DC 2900 Autostart. Plug the handheld power tool into the power socket on the unit. Set the selector switch to the AUTO position. The dust extractor will start automatically when the power tool is started.



Supplied with (Part No)

Suction hose (Ø38mm/1.5"), 5 m/16 ft (2111)
 Antistatic suction hose (Ø38/1.5"), 5 m/16 ft (2012)
 UK/US/CAN models
 Connecting sleeve (2115)
 Coupling socket (2108)
 Floor nozzle B370/W17" (7235)
 Chrome suction pipe Ø38mm/1.5" (7257)
 Plastic bag (42702)
 Fine filter, cellulose (42029)
 HEPA H13 filter (42027)

Technical data

H x W x L (cm/inch)	111x44x55 /43"x17"x21"
Weight	14 kg /30.8 lbs
Hose length	5 m /16 ft Ø38 mm /1.5"
Collector	20 l /5.3 US gal
Flow at open inlet	190 m³/h /114 cfm
Negative pressure, max 115/230V	21/24 kPa /84/96 inwg
Power consumption 115/230V	1285/1340 W
Sound level	68 dB(A)

DC 2900a

Collection in a container makes the DC 2900a ideal to use for sharp material such as metal chips.

Part No DC 2900a, 50/60 Hz

121000	230V /50 Hz, EU
121003	230V /50 Hz, UK
121008	230V /50 Hz, CH
121013	115V /50 Hz, UK
121015	115V /60 Hz, US/CAN
121100	230V /50 Hz, Auto start*, EU

121000-3 DC 2800H ENT 230V/50Hz

Based on the DC 2900a. The machine has a switch allowing the user to choose the level of air flow at which a warning signal shall be given.



Supplied with (Part No)

Suction hose (Ø38 mm/1.5"), 5 m/16 ft, antistatic (2012)
 Floor nozzle B370 /W17" (7235)
 Chrome suction pipe Ø38 mm/1.5" (7257)
 Fine filter, polyester (42028)
 HEPA H13 filter (42027)

Technical data

H x W x L (cm/inch)	111x44x55/ 43"x17"x21"
Weight	19 kg /42 lbs
Hose length	5 m /16 ft Ø38 mm /1.5"
Container	40 l /10.56 US gal
Flow at open inlet	190 m³/h /114 cfm
Negative pressure, max 115/230V	21/24 kPa / 84/96 inwg
Power consumption 115/230V	1285/1340 W
Sound level	68 dB(A)

Single-Phase Dust Extractors

DC Tromb 400

1-phase



The DC Tromb 400 is designed to meet modern safety requirements and work in conjunction with tools that have become ever more efficient and that therefore produce more dust than they have previously.

The maximum air flow is as high as 400 m³/h/ 247 cfm which is more than enough capacity for equipment such as floor grinders with a working width of 500 mm /19" and large electric cut off saws. It is easy to transport around construction sites, move in stairwells and lift into tight spaces. The wheels are puncture-proof and won't leave marks on the floor. The front wheels are lockable to enable working on uneven ground.

The DC Tromb can be supplied with three different collection variants: container, bag or Longopac.



DC Tromb 400a



DC Tromb 400c

Part No DC Tromb 400

162000	a	230V /50Hz, EU
162001	a	115V /60Hz, UK
162002	a	115V /60Hz, US/CAN
162008	a	230V /50Hz, CH
161500	c	230V /50Hz, EU
161501	c	115V /60Hz, UK
161503	c	230V /50Hz, UK
161502	c	115V /60Hz US/CAN
161508	c	230V /50Hz, CH
161530	L	230V /50Hz, EU
161531	L	115V /60Hz, UK
161532	L	115V /60 Hz, US/CAN
161538	L	230V /50Hz, CH



Single-Phase Dust Extractors

DC Tromb 400



Supplied with (Part No)

Connecting sleeve (2129)
 Coupling socket (2008)
 Suction hose, antistatic Ø50mm/ 2", 5 m/16 ft (2013)
 Suction hose Ø50 mm /2" 5 m /16 ft (2401) on models
 161500 and 161508
 Floor nozzle (7238)
 Suction pipe Ø50 mm /2" (7265)

Discharge:

"a" model (40 l /10 US gal container 40070)
 "c" model (10 x plastic bags 43619)
 "L" model (Longopac 20 m /65 ft 432177)
 Fine filter, polyester (44017)
 HEPA H13 filter (44016)



Technical data

H x W x L (cm/inch)	139x56x70 /54"x22"x27"
Weight	a/ 50 kg /110 lbs c/ 46 kg /101 lbs L/ 48 kg /106 lbs
Inlet	Ø 76 mm /3"
Collection	40 l/10 US gal / 20 l/ 5 US gal longopac
Flow at open inlet 115/230V	330/393 m ³ /h /188 cfm
Max flow 115/230V	360/420 m ³ /h / 212 cfm
Negative pressure, max 115/230V	21/25 kPa /84/100 inwg
Power consumption 115/230V	2100/2680/3000 W
Sound level	70 dB(A)



DC Tromb 400L



Single-Phase Dust Extractors

DC 3800 Wood Shavings Extractor



The DC 3800 Wood Shavings Extractor is designed especially to be connected to the carpentry equipment. It is suitable for source extraction on most saws where continuous operation and a high degree of separation is required. The DC 3800 Wood Shavings Extractor is a robust mobile machine that is easy to move around.

As with all of Dustcontrol's mobile dust extractors, the DC Wood Shavings Extractor is very easy to service.

Part No DC 3800 Wood Shavings Extractor
118400 230V /50 Hz, EU



Technical data

H x W x D (cm/inch)	138x60x70 /54"x23"x27"
Weight	37 kg /81 lbs
Hose length	7.5 m /22ft Ø50 mm/ 2"
Container	90 l /23 US gal
Flow at open inlet	320 m ³ /h /188 cfm
Negative pressure	24 kPa /96 inwg
Power consumption	2600 W
Sound level	70 dB(A)



Supplied with (Part No)

Connecting sleeve (2129)
Suction hose Ø50 mm/2", 7.5 m/ 22 ft
antistatic (2013)
Floor nozzle B 500 mm / W 19.7" (7238)
Chrome suction pipe Ø50 mm/2" (7265)
Plastic bag (4714)
Fine filter, polyester (42025)
HEPA H13 filter (42024)





Three-Phase Dust Extractors

DC 3900a Turbo DC 3900c Turbo

3-phase 

The DC 3900c Turbo is a medium-sized dust extractor with a tall cyclone and a three-phase motor that enables it to handle large quantities of debris.

This dust extractor is suitable for long hoses (up to 20 m / 65 ft), heavy cleaning (38 mm / 1.5" accessories) and for source extraction from power tools such as grinders, hammers and saws. Suitable casings are those for sanding, grinding and diamond discs up to 9" (230 mm) as well as rubber bellows for chisel hammers, drills and jackhammers (part no 6078 & 6130).



Part No DC 3900a/c Turbo

133000	c 400V/ 50 Hz, EU
133002	c 460V/ 60 Hz, US/CAN
133100	a 400V/ 50 Hz, EU

Supplied with (Part No)

Hose set, 7 m / 23 ft, 5 m / 16 ft (Ø50 mm / 2") and 2 m / 6.5 ft (Ø38 mm / 1.5"), (2125)
 Floor nozzle B450 (7236)
 Suction pipe, Ø50 mm / 2" (7257)
 Plastic bags (43619)
 Fine filter, polyester (42025)
 HEPA H13 filter (42024)

Technical data

H x W x D (cm/inch)	145x60x97 / 57"x23"x38"
Weight	62 kg / 137 lbs
Hose length	5 m / 16 ft (Ø50mm / 2")
Collection	40 l / 10 US gal
Flow at open inlet	260 m³/h / 188 cfm
Negative pressure	30 kPa / 124 inwg
Power consumption	2.2 kW / 4 hp
Sound level	75 dB(A)

DC 5900a 4 kW/10hp

3-phase 

All DC 5900s are powerful and reliable mobile dust extractors. They are built on a robust and sturdy steel chassis for maximum durability, for example on construction sites. With a direct-driven, three-phase turbopump, the DC 5900 is suitable for continuous operation, conveying heavy material away, source extraction and cleaning.

The DC 5900 provides sufficient air flow for several users at the same time and it can also be used as a semi-mobile central unit in a tubing system. It is suitable for source extraction for grinding discs up to approx. 800 mm / 31" in diameter.



Part No DC 5900a

119302	400V/ 50 Hz/ 4kW
119309	460V/ 60 Hz/ 10hp, US
119310	600V/ 60 Hz/ 10hp, CAN

Supplied with (Part No)

Coupling socket (2107)
 Coupling socket (2008)
 Suction hose, antistatic, Ø50 mm / 2", 7.5 m / 22 ft, (2013)
 Floor nozzle B 500 mm / W 19.7" (7238)
 Suction pipe Ø50 / 2" (7265)
 Fine filter, polyester (429204)
 HEPA H13 filter (42869)
 Container 75 l / 19 US gal (7368)

Technical data

H x W x D (cm/inch)	194x78x116 / 76"x30"x45"
Weight	176 kg / 388 lbs
Container	75 l / 19 US gal
Flow at open inlet	470 m³/h / 353 cfm
Negative pressure	28 kPa / 132 inwg
Power consumption	4 kW / 10 hp
Sound level	75 dB(A)

Three-Phase Dust Extractors

DC 5900c 4 kW/10hp



All DC 5900s are powerful and reliable mobile dust extractors. They are built on a robust and sturdy steel chassis for maximum durability, for example on construction sites. With a direct-driven, three-phase turbopump, the DC 5900 is suitable for continuous operation, conveying heavy material away, source extraction and cleaning.

The DC 5900 provides sufficient air flow for several users at the same time and it can also be used as a semi-mobile central unit in a tubing system. It is suitable for source extraction for grinding discs up to approx. 800 mm/ 31" in diameter.



Part No DC 5900c

119300	400V/ 50Hz/ 4 kW
119307	460V/ 60 Hz/ 10hp, US
119308	600V/ 60 Hz/ 10hp, CAN

Supplied with (Part No)

Coupling socket (2107)
Coupling socket (2008)
Suction hose Ø50 mm/ 2", 7.5 m/ 22 ft (2401)
Floor nozzle B, 500 mm / W 19.7" (7238)
Suction pipe, Ø50 /2" (7265)
Plastic bags, 10 pcs (46145)
Fine filter, polyester (429204)
HEPA H13 filter (42869)

Technical data

H x W x D (cm/inch)	192x76x100 /75"x30"x39"
Weight	176 kg /388 lbs
Collector	60 l /15 US gal
Flow at open inlet	470 m ³ /h /353 cfm
Negative pressure	28 kPa /132 inwg
Power consumption	4 kW /10 hp
Sound level	75 dB(A)

DC 5900a 7.5kW DC 5900c 7.5kW



The DC 5900 7.5 kW is equipped with a frequency converter, which makes it suitable for use where only 16A is available. The machine is a powerful dust extractor with a large air flow, ideal for applications such as floor grinding.

Part No DC 5900a/c 7.5kW

119303	c 400V/ 50 Hz/ 7.5 kW, EU
119318	a 400V/ 50 Hz/ 7.5 kW, EU



Supplied with (Part No)

Coupling socket (2129)
Coupling socket 76/50 (2008) and 50/50 (2107)
Suction hose Ø50 mm/ 2", 7.5 m/ 22 ft (2401)
Suction hose, antistatic Ø50 mm, 7.5 m (2013) on model 119318
Floor nozzle, B500/50 (7238)
Suction pipe, Ø50 (7265)
Fine filter, polyester (429204)

Technical data

H x W x D (cm/inch)	194x78x116 /76"x30"x45"
Weight	210 kg /463 lbs
Collection	60 l /16 US gal
Flow at open inlet	630 m ³ /h /371 cfm
Negative pressure	28 kPa /112 inwg
Power consumption	7.5 kW
Sound level	75 dB(A)

Three-Phase Dust Extractors

DC 5900c 9.2kW S DC 5900a 9.2kW S



The machine is primarily intended to be used for pneumatic conveying or the removal of very heavy material in conjunction with a pre-separator. The extra-large suction capacity can also be utilised for regular source extraction and cleaning in situations where extra long hoses up to 50 m are required. To prevent overheating during intensive use, the pump has been equipped with a cold air intake.

The reverse pulse filter cleaning system provides extra-long filter life and ensures no loss of suction.



Supplied with (Part No)

Fine filter, polyester (429204)
HEPA H13 filter (42807)

Technical data

H x W x D (cm/inch)	194x78x116 /76"x30"x45"
Weight	200 kg /440 lbs
Collection	Container/Bag
Flow at open inlet	500 m ³ /h /294 cfm
Negative pressure	40 kPa /160 inwg
Power consumption	9.2 kW /15hp
Sound level	75 dB(A)

Part No DC 5900c/a 9.2 kW S

119340 c 400V /50Hz, 60 l bag
119341 a 400V /50Hz, 75 l container

DC 5900c 9.2kW P /15hp DC 5900a 9.2kW P /15hp



The DC 5900 9.2 kW P generates an extremely large airflow and is therefore optimised for many extraction points. It is generally used in semi-mobile extraction systems where the machine is conveniently positioned in a central location and connected to a tubing system. Maximum efficiency is achieved and maintained with up to four simultaneous users.



Supplied with (Part No)

Fine filter, polyester (429204)
HEPA H13 filter (42807)

Technical data

H x W x D (cm/inch)	194x78x116 /76"x30"x45"
Weight	210 kg /463 lbs
Collection	Container/bag/Longopac
Flow at open inlet	800 m ³ /h /471 cfm
Negative pressure	28 kPa /112 inwg
Power consumption	9.2 kW /15hp
Sound level	75 dB(A)

Part No DC 5900c/a 9.2kW P /15hp

119301 c 400V /9.2 kW /50Hz, 60 l bag
119305 a 400V /9.2 kW /50Hz, 75 l container
119314 c 460V /15hp /60Hz, 60 l bag, US/CAN
119315 a 460V /15hp /60Hz, 75 l container, US/CAN
119316 c 600V /15hp /60Hz, 60 l bag, US/CAN
119317 a 600V /15hp /60Hz, 75 l container, US/CAN

I-Line – Quiet and Powerful

In some industrial applications, a portable dust extractor is preferred over a stationary system. In some of these industrial settings, sound can be a detriment or health hazard, a quiet unit is often desirable. Dustcontrol's I-line are as portable indoor vacuum units since the vacuum producer is highly sound insulated.

The i-line dust extractors can be "docked" to a permanent or temporary tubing system. Ideally these units are used for source extraction with handheld power tools, but can also

be used for heavy cleaning, such as metal chips. The vacuum producer is a turbo pump directly driven by a three-phase motor, providing reliability, long life and minimal service requirements. The characteristics of the turbo pump are well suited for heavy cleaning and material transport – the greater the resistance, the more vacuum generated.

DC 3800i

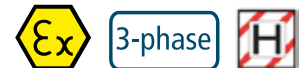

The DC 3800i combines central system performance with the flexibility of a portable machine. It is used with Ø 1.5"/38 mm accessories for heavier applications such as lathes and milling machines that generate large volumes of particles and chips. It is suitable for welding, metal chip, aluminum chips, swarf, material transport and cleaning.



Supplied with (Part No)

- 13556A05K0:** Suction hose 7 m (5 m Ø 50 and 2 m Ø 38, standard) (2125)
- 117206:** Antistatic hose set total 23' / 7 m (Ø 1.5" x 6' + Ø 2" x 17' / Ø 38 mm x 2 m + Ø 50 mm x 5 m) (2126 + 2107 + 2114)
- Aluminium floor tool B 450, Ø1.5"/38 mm (7236)
- Suction pipe, Ø1.5"/38 mm (7257)
- Chrome steel flat nozzle, Ø1.5"/38 mm, L=16"/400 mm (7213)
- Suction brush Ø1.5"/Ø38 (7278)
- Hand pipe Ø1.5"Ø38 (7035)
- Container 10.5 gal/40 l (40070)
- Fine filter, polyester (42025)

Part No	DC 3800i
13556A05K0	230/ 400 V /50 Hz, 2,2 kW
117206	230/ 460 V /60 Hz, 4,0 hp, USA/CAN

Capacity

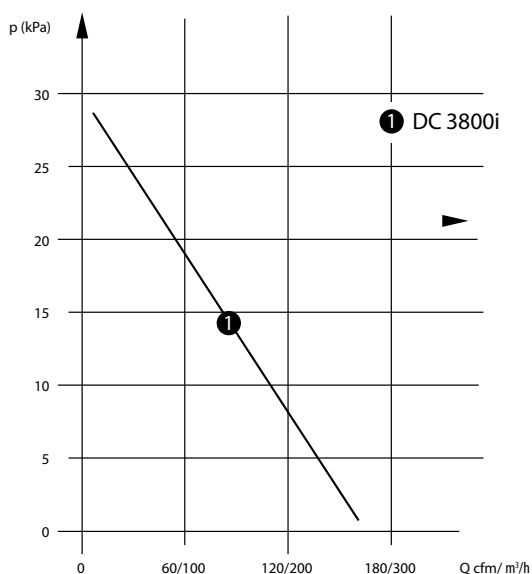

Technical data

HxWxL, in/cm	59x27x44/ 147x66x110
Weight, lbs/kg	190/86
Inlet, (nom)	Ø 2"/50 mm
Hose length max rec	15'-90' (Ø 2")/ 5-30 m (50 mm)
Max vacuum, inwg/kPa	120/30
Max Q, cfm/ m³/h	156 /260
Motor Nameplate	2.2 kW/4 hp
Fine Filter area, ft²/m²	19.5/1.8
Filter efficiency (EN 60335-2-69, Class M)	99,9 %
Collection container volume	10.5 gal/ 40 l
Sound level	60 dB(A)



EX-Line

The EX-line is specially designed for industries where there is a risk of explosion and also high demands for clean production, such as the wood, food production and electronics industries.

The machines fulfil the requirements of the ATEX Zone 22 directive 1999/92 ATEX 137. Cleaning accessories from Dustcontrol are also available to meet these regulations. Zone 22 is an area where an explosive environment, created by combustible airborne substances, does not

occur in normal operation or only occurs short-term. These machines are equipped with steel containers, earth-bonded parts and antistatic accessories. The machines for non-conducting material are enclosed to IP54 standard. For conductive material, IP65 standard is required. The machines are virtually maintenance free and can extract dust in a vast range of applications such as source extraction when using power tools for grinding, cutting and drilling applications as well as general cleaning.

DC 1800 H EX

DC 2800 H EX



DC 1800 H EX



DC 2800 H EX

The DC 1800 and 2800 H EX are suitable for general cleaning and source extraction. The DC 1800 H EX is small and lightweight and as such, suitable for those that need a highly portable machine that still is powerful enough for source extraction. The DC 1800 and 2800 H EX are equipped with a steel container. The machines are equipped with a brushless motor (for spark-free operation) and certified to IP54 standard (non conductive dust).

Technical data

Weight	18 kg/40 lb
Flow at open inlet, 115V	210 m ³ /h /124 ft ³ /m
Flow at open inlet, 230V	185 m ³ /h /109 ft ³ /m
Neg. Pressure max, 115V	30 kPa
Neg. Pressure max, 230V	25 kPa
Power consumption, 115V	1500 W
Power consumption, 230V	1300 W
Sound level	70 dB(A)
Container DC 1800	15 l/3.9 US gal
Container DC 2800	40 l/10.56 US gal

Part No DC 1800 H EX

114000	230V, 50/60 Hz, EU
114001	230V, 50/60 Hz, UK
114002	115V, 50/60 Hz, UK
114003	115V, 50/60 Hz, US/CAN

Supplied with (Part No)

Suction hose ATEX, Ø 38, 5 m/ 20 in. (2027)
 Floor nozzle (7235E)
 Suction pipe Ø 38 (7257)
 Fine filter, polyester (42028)
 HEPA H13 filter (42027)

DC 1800 DC 2800^{H EX} Stainless Steel



Dustcontrol's DC 1800/2800 EX are valued both for its easy handling and capacity when being used to reduce the risks of potential dust explosions in ATEX zone 22 (non-conductive dust).

However, there are areas with high hygienic demands (e.g. the food processing industry), which surpass the abilities of our standard DC 1800/2800 EX.

Suitable for operation in environments with potentially combustible dust (non-conductive); stainless steel design enables the use of alkaline wash solutions; high resistance to acids.



DC 1800^{EX} Stainless Steel



DC 2800^{EX} Stainless Steel



Supplied with (Part No)

- Suction hose, antistatic 38 ATEX (2027)
- Suction hose ATEX, Ø 38, 5 m/ 20 in (2007)
- Floor nozzle 370 A-38, ESD-certified (7235E)
- Suction pipe Ø38 Steel (7257)
- Fine filter, polyester (42028)
- HEPA H13 filter (42027)

Part No DC 2800 H EX Stainless Steel

114104	115V, 60 Hz, USA/CAN
114105	230V, 50 Hz, EU



Technical data

Weight	18/19 kg / 40/42 lb
Flow at open inlet, 115V	210 m ³ /h /124 ft ³ /m
Flow at open inlet, 230V	185 m ³ /h /109 ft ³ /m
Neg. Pressure max, 115V	30 kPa
Neg. Pressure max, 230V	25 kPa
Power consumption, 115V	1500 W
Power consumption, 230V	1300 W
Sound level	70 dB(A)

EX-Line

DC 3800 H Turbo EX



The DC 3800 H Turbo EX is a medium sized dust extractor with a high cyclone and a three-phase turbo motor. Thanks to the high cyclone, big filters and powerful motor package, it can handle large amounts of particles. Since it is equipped with a powerful three-phase turbo pump it is suitable for long hoses (up to 20 metres) and heavy cleaning (38mm accessories). It is certified to IP65 standard (conductive dust), ATEX Zone 22.



Supplied with (Part No)

Suction hose ATEX 7.4 m
2 m (2027) Ø 38, 5.4 m (2028) Ø 50
Floor nozzle (7236e)
Suction pipe Ø 50 (7257)
Fine filter, antistatic (4202501)
HEPA H13 filter, polyester (42024)
Cable length 7 m
Connector CEE plug 5 pol 16 A IP67

Technical data

Weight	70 kg
Flow at open inlet	260 m³/h
Negative pressure, max	28 kPa
Power consumption	2.2 kW /4 hp
Sound level	<70 dB(A)
Container	40 l

Part No	DC 3800H Turbo EX
13756A0GD0	400V /50Hz, Conductive dust / Non-conductive, IP65
114030	460V /60 Hz, 4 hp, Conductive dust, IP65

DC 5800 H Turbo EX



The DC 5800 H Turbo EX is designed for big hand held power tools and heavy cleaning. The unit is of robust and sturdy design for maximum dependability, coupled with a direct driven turbo pump for continuous operation. It is certified to IP65 standard (conductive dust).



Supplied with (Part No)

Suction hose ATEX, Ø 50 (2028)
Floor nozzle (7238e)
Suction pipe Ø 50 (7265)
Fine filter, antistatic (429206)
HEPA H13 filter (42869)

Technical data

Weight	ca 170 kg
Flow at open inlet	470 m³/h
Negative pressure, max	28 kPa
Power consumption	4 kW /10 hp
Sound level	75 dB(A)
Container	40 l

Part No	DC 5800H Turbo EX
119312	4 kW 400V /50 Hz
119313	10 hp 460V /60 Hz

EX-Line

Guide to the right EX-machine

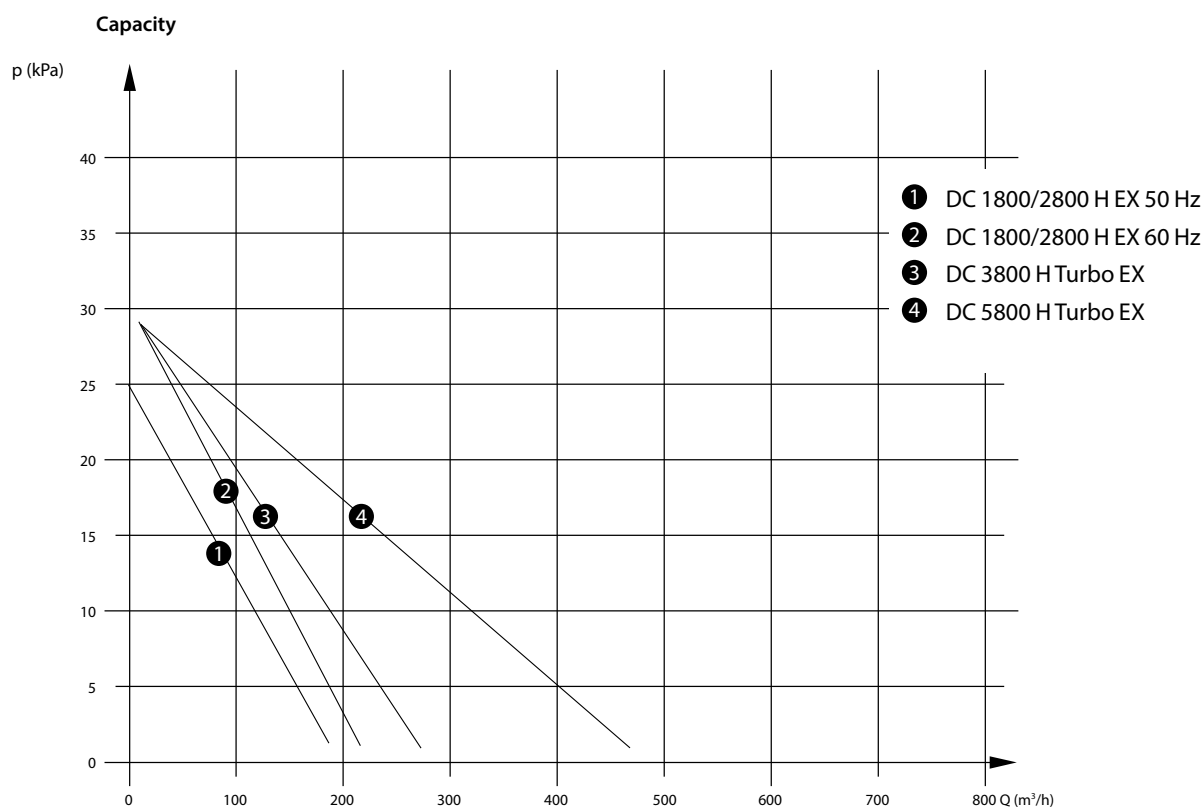

Technical data

	DC 1800 H EX	DC 2800 H EX	DC 3800 H Turbo EX	DC 5800 H Turbo EX
HxWxL (mm/in.)	830x402x382 / 33x16x15	1110x440x550	1400x600x970	1920x760x1000
Weight	18 kg / 40 lb	22 kg	70 kg	ca 170 kg
Inlet	X 50 mm / 2 in.	X 50 mm	X 50 mm	X 76 mm
Hose length (Ø 50)	5 m / 20 in. (Ø 38)	5 m (Ø 38)	5–20 m	5–30 m
Flow at open inlet	210/185 m³/h * / 124/109 ft³/m	210/185 m³/h *	260 m³/h	470 m³/h
Negative pressure, max	30/25 kPa	30/25 kPa *	28 kPa	28 kPa
Power consumption	1500/1300 W	1500/1300 W *	2.2 kW	4 kW
Filter area, fine filter	1.5 m² / 16 ft.²	1.5 m²	1.8 m²	8.4 m²
Degree of separation fine filter				
EN 60335-2-69, Class M	99 %	99 %	99 %	99 %
Filter area microfilter	0.85 m² / 9 ft.²	0.85 m²	1.5 m²	2.7 m²
Degree of separation				
Microfilter EN 1822-1	HEPA H13	HEPA H13	HEPA H13	HEPA H13
EN 60335-2-69, Class H	99.995 %	99.995 %	99.995 %	99.995 %
Container	20 l	40 l	40 l	40 l
Sound level (115/230 V)	70 dB(A)	70 dB(A)	< 70 dB(A)	75 dB(A)

*115V / 230V

Compressed Air Driven Dust Extractors

DC 1800 TR^{EX} DC 2800 TR^{EX}



The DC 1800/2800 TR EX removes dust in three stages. The first separation occurs in the unit's cyclone, which is a very efficient separation of all the coarser dust. The finer dust is separated in the unit's filter cartridges, and then the HEPA filter takes care the rest of the dust. Filter cleaning with pulse provides long filter life and constant capacity. Vacuum is created in the ejector. The ejector is maintenance free.

Part No 101890 DC 1800 TR EX



Supplied with (Part No)

Fine filter cellulose (42029)
Plastic bags (42384)
HEPA H13 filter (42027)



Technical data

HxWxL, in/cm	32x15x15/ 82.5x38x38
Weight, lbs/kg	22/10
Inlet, (nom)	Ø 2" /50 mm
Hose I max rec'd (Ø 2" /50 mm)	15' /5 m
Max Q, cfm /m ³ /h	102/170
CA consumption at 90psi /7 bar	5.3 gal/s /20 l/s
Air Connection	½" ball valve
Max vacuum, inwg/kPa	64/16
Fine Filter area, ft ² /m ²	16/1.5
Filtration efficiency	
- EN 60335-2-69, Class M	99 %
HEPA Filter area, ft ² /m ²	9.1/0.85
HEPA Filter efficiency	
- EN 60335-2-69, Class H	99.995 %
- EN 1822-1	HEPA H13
Collection bin volume	5.3 gal /20 l
Sound level	68 dB(A)

DC 2800 TR^{EX}



Description see DC 1800 TR EX above.

Part No 121090 DC 2800 TR EX



Supplied with (Part No)

Fine filter cellulose (42029)
Plastic bags, 5 pcs (42385)
HEPA H13 filter (42027)



Technical data

HxWxL, in/cm	47x17x22/ 119.5x44x55
Weight, lbs/kg	42/19
Inlet, (nom)	Ø 2" /50 mm
Hose I max rec'd (Ø 2" /50 mm)	15' /5 m
Max Q, cfm /m ³ /h	102/170
CA consumption at 90psi/7bar	5.3 gal/s /20 l/s
Air Connection	½" ball valve
Max vacuum, inwg/kPa	64 /16
Fine Filter area, ft ² /m ²	16 /1.5
Filtration efficiency	
- EN 60335-2-69, Class M	99%
HEPA Filter area, ft ² /m ²	9.1/0.85
HEPA Filter efficiency	
- EN 60335-2-69, Class H	99.995 %
- EN 1822-1	HEPA H13
Collection bin volume	10.5 gal/40 l
Sound level	68 dB(A)

Compressed Air Driven Dust Extractors

DC 3800 TR S EX



The DC 3800 TR S EX is a compressed air driven extractor for use in areas where electrical power is not available or practical. The DC 3800TR S EX is a machine with large suction capacity and robust construction while still being compact and easy to maneuver. It is ideal for source extraction on most types of hand-held tools and for industrial cleaning (38 mm and 50 mm system). The DC 3800 TR S EX is supplied with a HEPA filter.

Part No 117100 DC 3800 TR S EX



Supplied with (Part No)

Fine filter, antistatic (4202501)
HEPA H13 filter (42024)



Technical data

HxWxL, in/cm	55x24x36/ 139x60x92
Weight, lbs/kg	84/38
Inlet, (nom)	Ø 2"/50 mm
Hose l max rec'd (Ø 2" /50 mm)	15'-50'/5-15m
Max Q, ft ³ / m ³ /h	14126/400
CA consumption at 90psi/6 bar	63.5cfm/20 l/s
Air Connection	1" ball valve
Max vacuum, inwg/kPa	80/20
Fine Filter area, ft ² /m ²	19.3/1.8
Filtration efficiency	
- EN 60335-2-69, Class M	99 %
HEPA Filter area, ft ² /m ²	16/1.5
HEPA Filter efficiency	
- EN 60335-2-69, Class H	99.995 %
- EN 1822-1	HEPA H13
Collection bin volume	10.5 gal/40 l
Sound level	75 dB(A)

DC 5800 TR

The DC 5800 TR is a machine driven by compressed air for use in areas where electricity is not available or not permitted. The DC 5800 TR has a very robust design and extra high extraction power, which makes it ideal for source extraction on bigger machinery and in mines. It is also ideal for source extraction from most types of hand held power tools.

Part No 119390 DC 5800 TR



Supplied with (Part No)

Plastic bags, 5 pcs (46145)
Fine filter, polyester (429204)



Technical data

HxWxL, in/cm	71x30x40/ 180x76x100
Weight, lbs/kg	330/150
Inlet, (nom)	Ø 3"/76 mm
Hose l max rec'd	15'-50'/5-10m
Max Q, cfm /m ³ /h	300/500
CA consumption at 90psi /6bar	90 cfm/3.6m ³ /m
Air Connection	1" ball valve
Max vacuum, inwg/kPa	84/21
Fine Filter area, ft ² /m ²	53.8/5
Filtration efficiency	
- EN 60335-2-69, Class M	99 %
Collection bag volume	15.5 gal/60 l
Sound level	75 dB(A)



Accessories

HEPA Filter area, ft² /m² 16/1.5
HEPA Filter efficiency
- EN 60335-2-69, Class H 99.995 %
- EN 1822-1 HEPA H13



“All Dustcontrol machines are able to vacuum small amounts of liquid, but for those of you who deal with larger quantities of water, we have developed a range of professional wet-vacs that can handle the toughest environments.”

Wet-Vacs

DC 50W DC 75W

eco 1-phase



DC 50 Wet-Vac

DC 75 Wet-Vac

When drilling in concrete, large quantities of water are required, which becomes very dirty. Using a wet-vac to effectively extract the water prevents both the workplace from becoming wet and dirty, and the sewerage system from silting up. The slurry solids are collected in a filter bag for easy handling and disposal.

Dustcontrol's wet-vacs are easy to disassemble for cleaning and decontamination. This is an important benefit on units that require frequent cleaning. Robust construction helps these units resist the knocks from everyday use.

Part No	Wet-Vacs
118600	DC 50W, 230V, 50 Hz, EU
118700	DC 75W, 230V, 50 Hz, EU



DC 50W Supplied with (Part No)

Coupling socket (2108)
 Connecting sleeve (2114)
 Suction hose Ø38 mm /1.5", 5 m /16ft, antistatic (2012)
 Floor nozzle B370mm /W14"(7236)
 Suction pipe Ø38, aluminium (7258)
 Filter bag (42190)



DC 50W Technical data

H x W x D (cm/inch)	87x63x54/ 34"x25"x21"
Weight	34 kg /75 lbs
Hose length	5 m /16 ft Ø38 mm /1.5"
Flow at open inlet	190 m ³ /h
Negative pressure 230V	24 kPa
Vacuum motor, single-phase 230V	1285 W
Pump, single-phase	550 W
Sound level	75 dB(A)



DC 75W Supplied with (Part No)

Coupling socket (2108)
 Connecting sleeve (2115)
 Suction hose Ø38 mm/1.5", 5 m /16ft, antistatic (2012)
 Floor nozzle B370mm /W14"(7236)
 Suction pipe Ø38, aluminium (7258)
 Filter bag (42190)



DC 75W Technical data

H x W x D (cm/inch)	98x63x55/ 38"x25"x21"
Weight	37 kg /81 lbs
Hose length	5 m /16 ft Ø38 mm /1.5"
Flow at open inlet	190 m ³ /h
Negative pressure 230V	24 kPa
Vacuum motor, single-phase 230V	1400 W
Pump, single-phase	550 W
Sound level	75 dB(A)

Air Cleaner

DC AirCube 500



The DC AirCube 500 has been developed for ease of use and durability. The fan unit is a radial blower with specially designed to build up high pressure across its entire flow range. This means that the unit generates a large amount of airflow during the entire lifetime of the filter. An exhaust hose can be used to create negative pressure in a sealed room. The fan has two speed settings, which means that the unit can be run economically, for example during the night.

Part No	DC AirCube 500
112500	230V, 50 Hz, EU
112501	230V, 50 Hz, UK
112503	115V, 50 Hz, UK
112508	230V, 50 Hz, CH
112505	115V, 60 Hz, US/CAN



Technical data

H x W x D (cm/inch)	38x34x50 /15"x13"x20"
Weight	13 kg /28,6 lbs
Inlet/Outlet Ø	38x34 cm /Ø125 1.5x1.3 inch /Ø5"
Power consumption, fan	145/210 W
Flow at open inlet, max	470/500 m ³ /h 276/353 cfm
Pre-filter area	0,18 m ² /1.9 ft ²
HEPA filter area	4.2 m ² /45 ft ²
Filter class	H13
Sound level	45-65 dB (A)



Accessories (Part No)

- Hose 125 (2420)
- Funnel connection (42753)
- Hose clamp (4138)
- HEPA H13 filter (42692)
- Pre-filter (42690)

Dustcontrol's high-efficiency air cleaner – the DC AirCube – is equipped with a HEPA H13 filter to separate dust and particles down to 0.3 microns. The DC AirCube contributes to a healthier working environment.



Dust class H (degree of permeability $\leq 0.005\%$) for particles as small as 0.1 μm and carcinogenic particles. According to IEC/EU 60335-2-69

Air Cleaner

DC AirCube 1200



The DC AirCube 1200 is a highly efficient and robust air cleaner with the ability to clean the air even in large rooms, at a rate of up to 1,060 m³/h /647 cfm. The encapsulated fan housing contains a radial blower type fan that builds up high pressure across its entire flow range, which provides effective air cleaning for the entire lifetime of the filter. The speed of the fan is also continuously variable in order to save energy. The DC AirCube 1200 is equipped with both a HEPA H13 filter that captures the smallest particles and a light that indicates when it is time to replace the filter.



Part No	DC AirCube 1200
111000	230V, 50 Hz EU
111001	230V, 50 Hz UK
111002	115V, 50 Hz UK
111008	230V, 50 Hz CH
111003	115V, 60 Hz US/CAN

+ Accessories (Part No)

Hose kit (42657)
Bend 90° (42660)
HEPA H13 filter (42940)
Pre-filter (42918)

Technical data

H x W x D (cm/inch)	86x43x55/ 34"x17"x21"
Weight	23 kg /51 lbs
Inlet/Outlet Ø	25/31.5 cm 0.98/1.24 inch
Power consumption, fan	375/385 W
Flow at open inlet, max	1660 m ³ /h /977 cfm
Pre-filter area	0.40 m ² /4.3 ft ²
HEPA filter area	5 m ² /54 ft ²
Filter class	H13
Sound level	60-68 dB (A)

DC AirCube 2000



With a capacity of approximately 1.800 m³/h /1059 cfm the DC AirCube 2000 is the Dustcontrol's most powerful cleaner.

The DC AirCube 2000 has a robust, stainless-steel chassis and an encapsulated fan with variable speed setting. With its ergonomic design, it is easy to carry and transport. It can also be operated when positioned horizontally.

The DC AirCube 2000 has a HEPA H13 filter with an area totalling 10m²/107ft². An integrated light indicates when it is time to replace the filter.



Part No	DC AirCube 2000
102000	230V, 50 Hz, EU
102002	230V, 50 Hz, UK
102003	115V, 50 Hz, UK
102008	230V, 50 Hz, CH
102004	115V, 60 Hz, US/CAN

+ Accessories (Part No)

Hose kit (42657)
Bend 90° (42660)
HEPA H13 filter (42896)
Pre-filter (42917)

Technical data

H x W x D (cm/inch)	102x56x70 /40"x22"x27"
Weight	30 kg /66lbs
Inlet/Outlet Ø	315/315 mm 12.4/12.4 inch
Power consumption, fan	360 /505 W
Flow at open inlet, max	1800 m ³ /h /1059 cfm
Pre-filter area	0.5 m ² /5.4 ft ²
HEPA filter area	10 m ² / 107 ft ²
Filter class	H13
Sound level	60-68 dB (A)

Guide to the right machine

Pressure generation and airflow of our machines

kPa vs m³/h

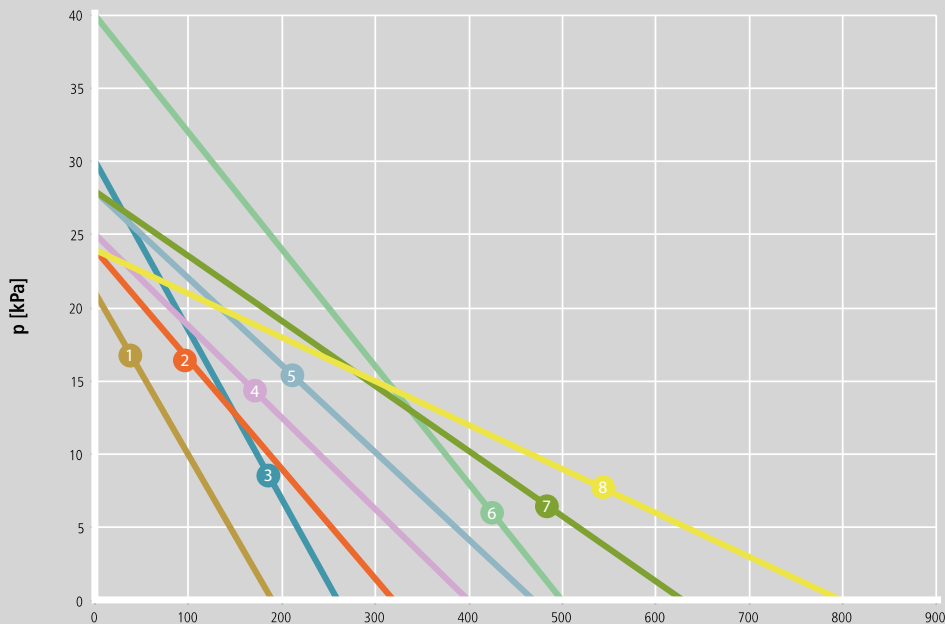

kPa vs m³/h

- 1 DC 2800H Asbest & DC 1800 & DC 2900
- 2 DC 3900, DC 3900 Twin & DC 3800 Wood Shavings Extractor
- 3 DC 3900 Turbo & DC 3900 Twin Turbo
- 4 DC Tromb 4000
- 5 DC 5900 4kW, DC 5900 PTFE
- 6 DC 5900 9.2kW S
- 7 DC 5900 7.5kW
- 8 DC 5900 9.2kW P

cfm vs inwg

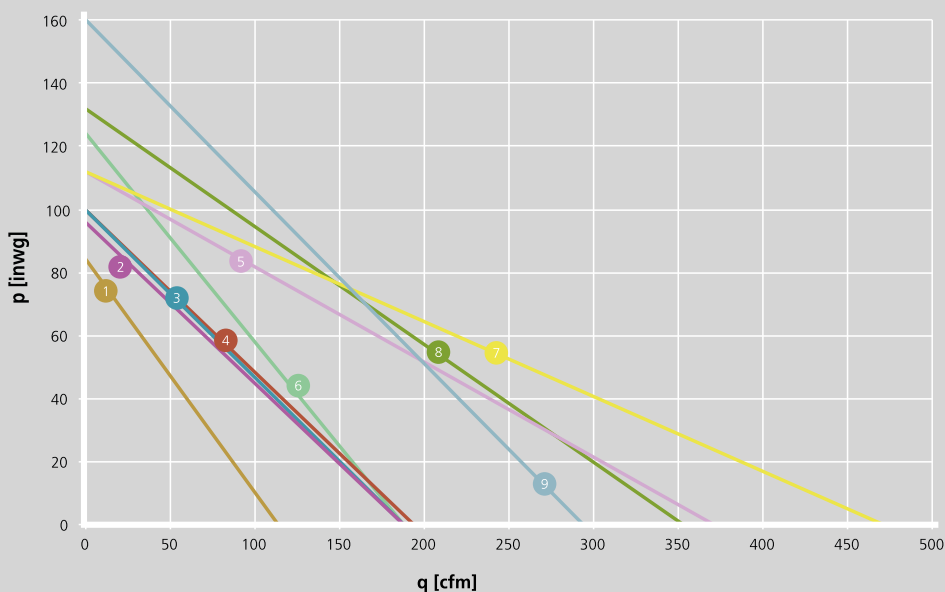

cfm vs inwg

- 1 DC 1800, DC 2900a, DC 2900c, DC 2800H Asbest
- 2 DC 3800 Wood Shavings Extractor
- 3 DC 3900a, DC 3900c, DC 3900L, DC 3900L
- 4 DC Tromb 400a, DC Tromb 400c, DC Tromb 400L
- 5 DC 5900c 7.5 kW, DC 5900L 7,5 kW
- 6 DC 3900c Turbo, DC 3900c Twin Turbo
- 7 DC 5900c 9.2 kW P
- 8 DC 5900c PTFE, DC 5900a 4 kW, DC 5900c 4 kW, DC 5900L 4 kW
- 9 DC 5900c 9.2 kW S

Healthy Business

Dustcontrol

®

Accessories and Consumables

To achieve optimal performance from your vacuum system or mobile dust extractor all elements of the solution have to be in balance. The accessories are at least as important as the vac producer to provide best results. On top of our standard program presented here, we can and have produced various tailor made solutions to solve our customers' specific needs.



About Suction Hoses

Hoses need to have different characteristics depending on their intended use. Dustcontrol supplies hoses that are:

- wear-resistant, lightweight and flexible
- unaffected by extremes of temperature
- crushproof
- antistatic

When using long suction hoses that are coupled together, the hose closest to the suction casing should be the one with the smallest diameter and it should be no longer than 9,8 ft /3 m. Coupling should be carried out using external couplings that are easy to use.

Antistatic accessories – ESD certification

ESD-accessories are certified according to Swedish National Testing and Research Institute (SP) according to SP-Method 2472.

Measured values to ground connection should be less than 10⁶ Ohm as stated by clause 11 in CENELEC TR 50404:2003, and the measured resistances should be less than 10⁹ Ohm as stated according to sub-clause 7.4.3 a, in EN 60079-0:2009 and 4.2 in CENELEC TR 50404:2003.

To order an antistatic (ESD) version, add E to the end of part no.



Our selection of Suction Hoses

Product	Part No	Dimension Ø	Standard length ft /m	Colour	Material	Temp °F /°C max/min	Anti-static/ESD	Abrasion resistance	UV and ozone resistance	Resistance to welding fumes	Resistance to solvent and oil
Suction hoses, standard	2001	3"/76 mm	32 /10	Blue	PE	140/-22/+60/-30	No	2	2	3	3
	2401	2"/50 mm	16,32,49 /5,10,15	Blue	PE	140/-22/+60/-30	No	2	2	3	3
	2111	1.5"/38 mm	16,32,49 /5,10,15	Blue	PE	140/-22/+60/-30	No	2	2	3	3
	2112	1.25"/32 mm	16,32,49 /5,10,15	Blue	PE	140/-22/+60/-30	No	2	2	3	3
	2113	1"/25 mm	16,32,49 /5,10,15	Blue	PE	140/-22/+60/-30	No	2	2	3	3
Suction hoses, heat-resistant	2004	2"/50 mm	16,32,49 /5,10,15	Grey	PP(EPDM)	194/-40/+90/-40	No	3	2	1	4
	2003	1.5"/38 mm	16,32,49 /5,10,15	Grey	PP(EPDM)	194/-40/+90/-40	No	3	2	1	4
Suction hoses, antistatic	2024*	3"/76 mm	32 /10	Black	PE	140/-4/+60/-20	Yes	2	2	3	3
	2013*	2"/50 mm	16,32,49 /5,10,15	Black	PE	140/-4/+60/-20	Yes	2	2	3	3
	2012*	1.5"/38 mm	16,32,49 /5,10,15	Black	PE	140/-4/+60/-20	Yes	2	2	3	3
	2005*	1.25"/32 mm	16,32,49 /5,10,15	Black	PE	140/-4/+60/-20	Yes	2	2	3	3
	2025*	1"/25 mm	16,32,49 /5,10,15	Black	PE	140/-4/+60/-20	Yes	2	2	3	3
	2027E*	1.5"/38 mm	16,32,49 /5,10,15	Black	PE	140/-4/+60/-20	Yes	2	2	3	3
	2028E*	2"/50 mm	16,32,49 /5,10,15	Black	PE	140/-4/+60/-20	Yes	2	2	3	3
Suction hoses, PU extra abrasion-resistant	2056	3"/76 mm	16 & 32 /5 & 10	Transparent	PU	194/-40/+90/-40	Yes**	1	1	3	1
	2054	2"/50 mm	16 & 32 /5 & 10		PU	194/-40/+90/-40	Yes**	1	1	3	1
	2055	1.5"/38 mm	16 & 32 /5 & 10		PU	194/-40/+90/-40	Yes**	1	1	3	1
Super D superelastic	2038	1.5"/38 mm	49 /15	Black/white	PVC	185/-23/+85/-5	No	2	2	2	4
	2039	2"/50 mm	49 /15	Black/white	PVC	185/-23/+85/-5	No	2	2	2	4

* To order an antistatic (ESD) version, add the letter E to the end of the part no.

** The wire helix must be bared and left in contact with conductive material for static discharge.



Suction Hoses – antistatic

- Better flexibility
- Smoother on the inside for improved air flow
- The conductivity is as good as the previous hose
- Longer life time
- Heat tolerance < 60 degree C

Resistance Scale

- 1 Excellent
- 2 Good
- 3 Limited
- 4 Poor

Suction Hoses

Metal Hose

Diameter (in/mm)	Part No.	Type	Temp °F max / Temp °C max	Material
2/50	2150	Flexible	572/+300	Steel
2/50	2151	Rigid	572/+300	Steel
1.5/38	2138	Flexible	572/+300	Steel
1.5/38	2139	Rigid	572/+300	Steel

Ventilation Hose

Diameter (in/mm)	Description	Part No
5/125	Ventilation hose 4.9"/125 mm	2420
10/250	Ventilation hose 10"/250 mm	2032
1.5/38	Flexible	2138
1.5/38	Rigid	2139

Compressed Air Hose

Diameter	Description	Part No
Ø _{in} 3/4"	Compressed air hose 3/4	2124
Ø _{in} 1/2"	Compressed air hose 1/2	2123
Ø _{in} 3/8"	Compressed air hose 3/8	2122
Ø _{out} 5 mm	Compressed air hose 5	2406
Ø _{out} 6 mm	Compressed air hose 6	8482
Ø _{out} 8 mm	Compressed air hose 8	8183

Hose Clamp

Description	d _{min} / d _{max}	Part No
Hose clamp	0.3"-0.6"/8-14 mm	4027
Hose clamp	0.4"-0.7"/11-17 mm	4028
Hose clamp	0.6"-0.9"/15-24 mm	4146
Hose clamp	1"-1.5"/26-38 mm	4197
Hose clamp	1.7"-2.2"/44-56 mm	4075
Hose clamp	2"-2.6"/50-65 mm	4219
Hose clamp	2.3"-3"/58-75 mm	4002
Hose clamp	2.7"-3.3"/68-85 mm	3002
Hose clamp	3"-3.7"/77-95 mm	4090
Hose clamp	3.4"-4.4"/87-112 mm	4310
Hose clamp	4.1"-5.4"/104-138 mm	4138
Hose clamp	5.1"-6.5"/130-165 mm	4040
Hose clamp	5.9"-7.1"/150-180 mm	4137
Hose clamp	7.9"-9.1"/200-231 mm	4464
Hose clamp	8.9"-10.1"/226-256 mm	4102

Suction Hoses

Rubber Suction hose

Diameter (in/mm)	Part No Standard	Part No extra abrasion resistant
6/152	2045	-
4/102	2011	-
3/76	See PU-suction hose	2046



Technical data

	2011	2046	2045
Material gauge (in/mm)	0.33/8.5	0.31/8	0.37/9.5
Min radius (in/mm)	11.81/300	8.27/210	18.9/480
Weight (lbs/yd /kg/m)	9.15/4.15	6.55/2.97	15.54/7.05
Temp max (°F /°C)	140/+60	140/+60	140/+60
min (°F /°C)	-13/-25	-13/-25	-13/-25
Internal tube	PVC	PVC	PVC
Insert	Steel helix	Steel helix	Steel helix copper wire
External tube	Polyester	Polyester	Polyester

Hose hanger

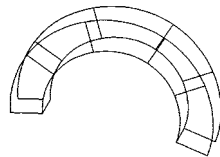

∅ designates the inside of the hose

Description	Part No
Hose hanger, white enamel	4473
Hose hanger, stainless	7214

Couplings for rubber suction hose/extra abrasion resistant

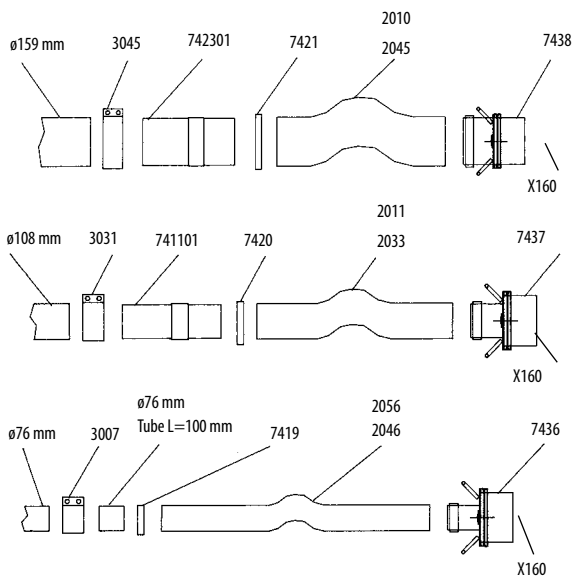

Part No	Description
3007	Joint ∅ 3"/76 mm
3031	Joint ∅ 4.3"/108 mm
3045	Joint ∅ 6.3"/160 mm
741101	Pipe connection 4.3"/4"/108/102 mm
7419	Hose clamp 3"/76 mm
7420	Hose clamp 4"/102 mm
7421	Hose clamp 6.3"/160 mm
742301	Pipe connection 6.3"/6"/159/152 mm
7436	Hose connector 3"/X6.3"/76/X160 mm
7437	Hose connector 4"/X6.3"/102/X160 mm
7438	Hose connector 6"/X6.3"/152/X160 mm

Suction Hoses

Turnable Hose Connectors

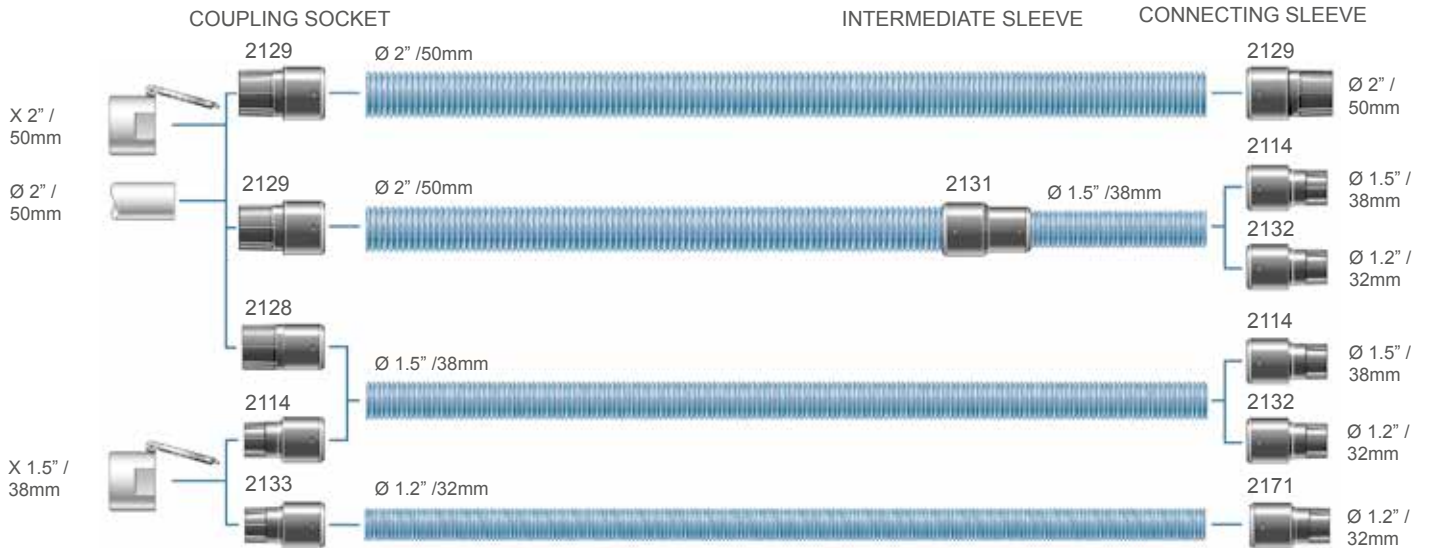

Part No	Description
2114*	Connecting sleeve, turnable Ø 1.5"/1.5" /38/38
2128*	Coupling socket, turnable Ø 2"/1.5" /50/38
2129*	Coupling socket, turnable Ø 2"/2" /50/50
2131*	Intermediate sleeve, turnable Ø 2"/1.5" /50/38
2132*	Connecting sleeve, turnable Ø 1.2"/1.5" /32/38
2133*	Coupling socket, turnable Ø 1.5"/1.2" /38/32
2171*	Coupling socket, turnable Ø 1.2"/1.2" /32/32



*To order an antistatic (ESD) version, add E to the end of part no.



Suction Hoses

Non-Turnable Hose Connectors

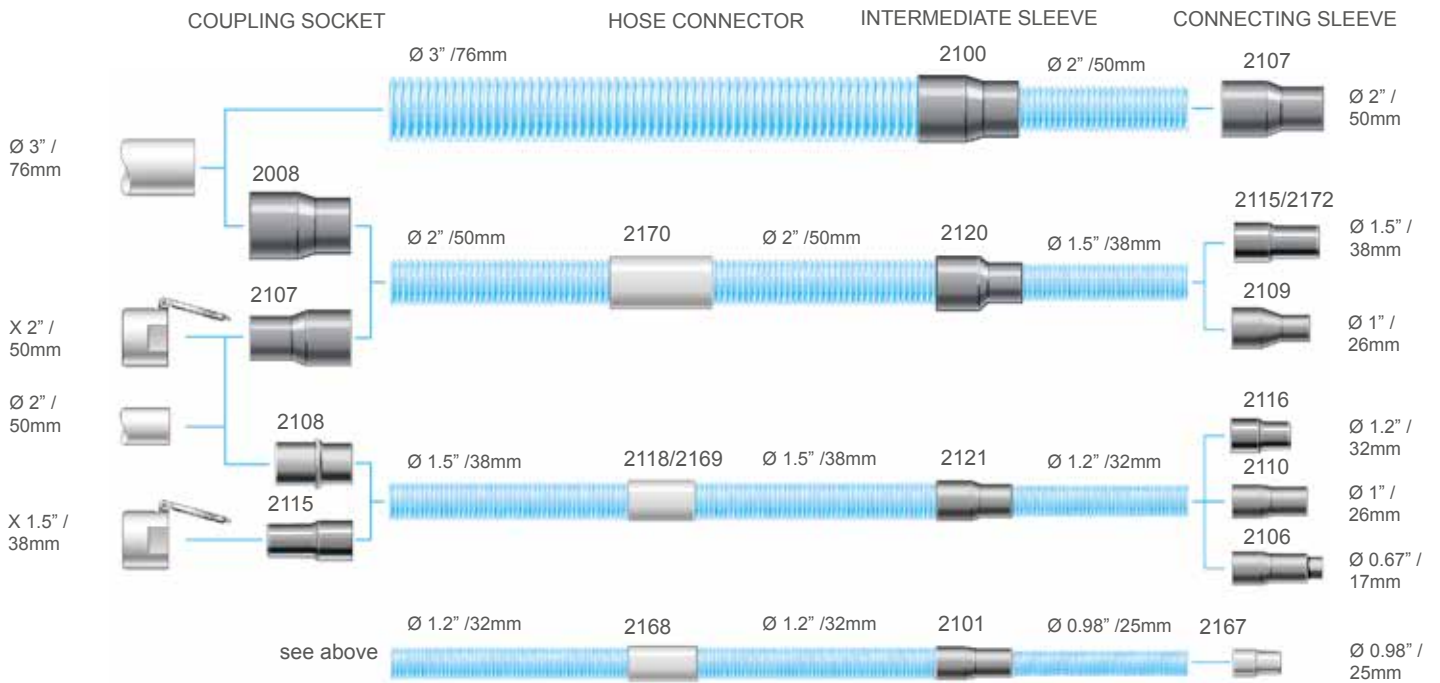

Part No Description

2008* Coupling socket $\text{Ø } 3''/2'' / 76/50$
 2100* Intermediate sleeve $\text{Ø } 3''/2'' / 76/50$
 2101* Intermediate sleeve $\text{Ø } 1.2''/0.98'' / 32/25$
 2106* Connecting sleeve $\text{Ø } 0.67''/1.2'' / 17/32$
 2107* Coupling socket $\text{Ø } 2''/2'' / 50/50$
 2108* Coupling socket $\text{Ø } 2''/1.5'' / 50/38$
 2109* Connecting sleeve $\text{Ø } 1''/1.5'' / 26/38$

2116 Connecting sleeve $\text{Ø } 1.2''/1.2'' / 32/32$
 2118 Hose connector $\text{Ø } 1.5'' / 38$
 2120* Intermediate sleeve $\text{Ø } 2''/1.5'' / 50/38$
 2121* Intermediate sleeve $\text{Ø } 1.5''/1.2'' / 38/32$
 2156* Coupling Nipple 75/72.5. 2156 is used to connect the 76mm hose to flap valve, 76/76 art. 3237

2167* Connecting sleeve $\text{Ø } 0.98''/0.98'' / 25/25$
 2168* Hose connector $\text{Ø } 1.2'' / 32$
 2169* Hose connector $\text{Ø } 1.5'' / 38$
 2170* Hose connector $\text{Ø } 2'' / 50$



*To order an antistatic (ESD) version, add E to the end of part no.



Suction Hoses

Turnable Connectors for PU section hoses

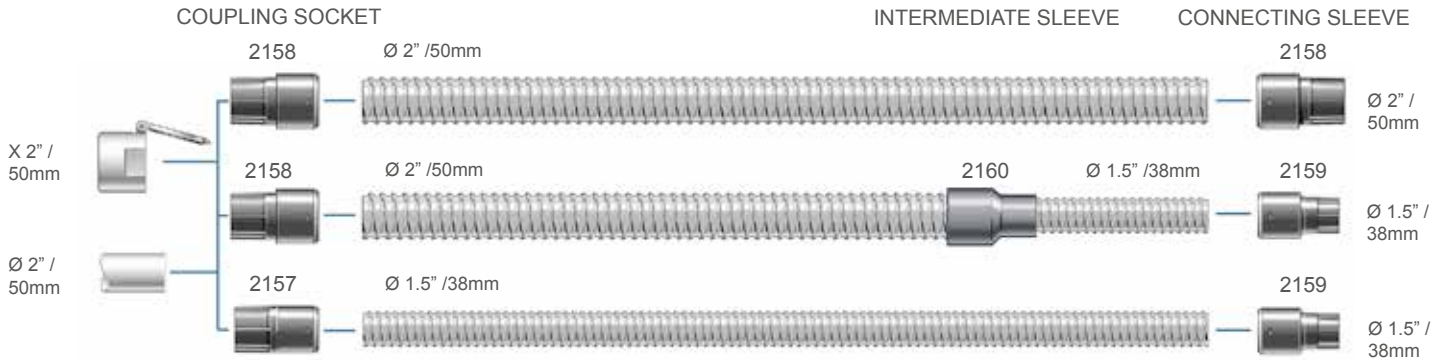

Non-Turnable Connectors for PU Suction Hoses

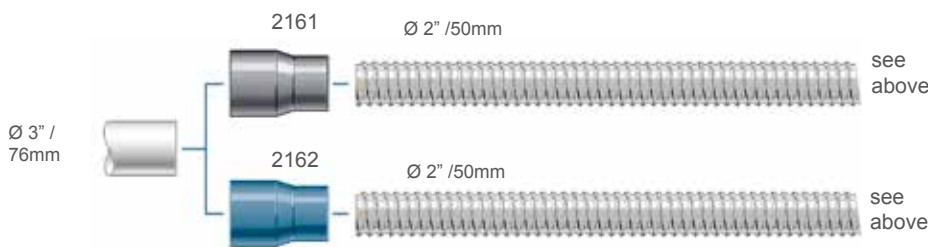

Part No	Description
2157*	Coupling socket Ø2"/1.5" 50/38 PU, turnable
2158*	Coupling socket Ø2"/2" 50/50 PU, turnable
2159*	Connecting sleeve Ø1.5"/1.5" 38/38 PU, turnable
2160*	Intermediate sleeve Ø 2"/1.5" 50/38mm PU, turnable
2161*	Coupling socket Ø3"/2" 76/50mm PU, EPDM
2162*	Coupling socket Ø3"/2" 76/50mm PU, Nitrile

Suction Hose Quick Coupler

Part No 2166

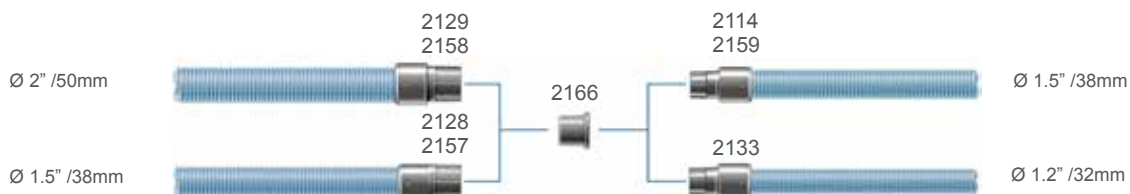

Part No 42497

Multi-Connection for Handheld Power Tools with Integrated Suction Casings

The multi-connection fits onto suction casings with an outlet diameter of 0,98-1,37 inch /25-35 mm. Cut off a section at the required diameter (it is pre-marked with: 25, 27, 29, 31, 33, 35 mm) and slip the multi-connection over the tubing. Connection sleeves 2114 or 2115 then fit onto the other end to connect the hose.

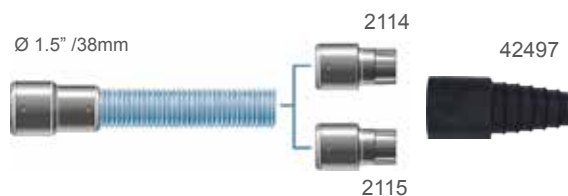

Part No	Description
42497*	Multi-connection for handheld power tools with integrated suction casings
2114*	Coupling socket Ø1.5"/1.5" 38/38mm, turnable
2115*	Coupling socket Ø1.5"/1.5" 38/38mm



*To order an antistatic (ESD) version, add E to the end of part no.

Suction Hoses

Hose Sets

Part No	Description
2125	Hose set Ø 50/38 L = 7 m Ø 2"/1.5" L = 23 ft
2126	Hose set Ø 50/38 L = 7 m Ø 2"/1.5" L = 23 ft antistatic
2006	Hose set Ø 38 L = 2 m Ø 1.5" L = 6.5 ft
2015	Hose set Ø 38/1.5" L = 2 m/6,5ft
2105	Hose set Ø 38/1.5" L = 5 m/16ft**

** Standard suction hose, turnable, non removable connector.
(Replacement to standard hose kit)

Standard suction hose, turnable
intermediate sleeve 50/38

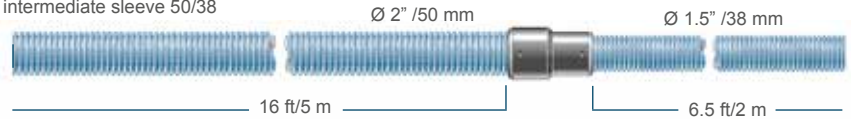

Antistatic suction hose, turnable
intermediate sleeve 50/38

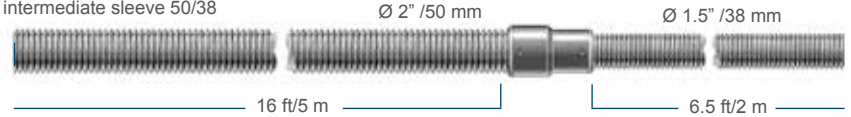

Standard suction hose, turnable
intermediate sleeve 50/38

Connects to Ø50
suction hose

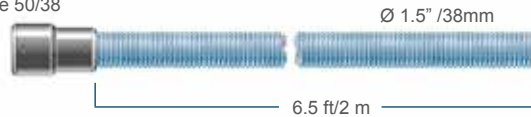

Standard suction hose, turnable
intermediate sleeve 50/38

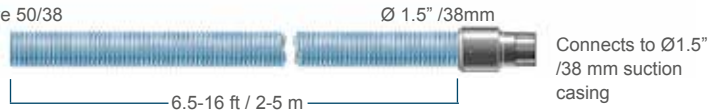

Characteristics of Materials

Description	Dimension Ø inch/mm	Part No	Colour	Material	Temp °F max/min/ Temp °C max/min	Antistatic	Abrasion resistance	UV and zone resistance	Resistance to welding fume	Resistance to solvent and oil
Coupling socket	3"/2"/76/50	2008*	Black	EPDM	284/-76/140/-60	Yes	2	1	2	4
	2"/2"/50/50	2107*	Black	EPDM	284/-76/140/-60	Yes	2	1	2	4
	2"/1.5"/50/38	2108*	Black	EPDM	284/-76/140/-60	Yes	2	1	2	4
	3"/2"/76/50 (PU)**	2161*	Black	EPDM	284/-76/140/-60	Yes	2	1	2	4
Coupling socket	3"/2"/76/50	2162*	Blue	NBR	248/-76/120/-60	Yes	2	3	3	2
Coupling socket	2"/2"/50/50	2129*	Black	PA12	284/-4/140/-20	Yes	1	2	3	1
	2"/2"/50/50 (PU)**	2158*	Black	PA12	284/-4/140/-20	Yes	1	2	3	1
	2"/1.5"/50/38 (PU)**	2157*	Black	PA12	284/-4/140/-20	Yes	1	2	3	1
	2"/1.5"/50/38	2128*	Black	PA12	284/-4/140/-20	Yes	1	2	3	1
	1.5"/1.25"/38/32	2133*	Black	PA12	284/-4/140/-20	Yes	1	2	3	1
	1.25"/1.25"/32/32	2171*	Black	PA12	284/-4/140/-20	Yes	1	2	3	1
Connecting sleeve	1.25"/1.5"/32/38	2132*	Black	PA12	284/-4/140/-20	Yes	1	2	3	1
	1.5"/1.5/38/38 (PU)**	2159*	Black	PA12	284/-4/140/-20	Yes	1	2	3	1
	1.5"/1.5/38/38	2114*	Black	PA12	284/-4/140/-20	Yes	1	2	3	1
	2"/2"/50/50	2129*	Black	PA12	284/-4/140/-20	Yes	1	2	3	1
	1"/1"/25/25	2167*	Black	PA12	284/-4/140/-20	Yes	1	2	3	1
Connecting sleeve	1.5"/1.5/38/38	2115*	Black	PA12	284/-4/140/-20	Yes	1	2	3	1
	1"/1.5"/26/38	2109*	Black	EPDM	284/-76/140/-60	Yes	2	1	2	4
	1"/1.25"/26/32	2110*	Black	EPDM	284/-76/140/-60	Yes	2	1	2	4
Connecting sleeve	.7"/1.25"/17/32	2106*	Black	EPDM	284/-76/140/-60	Yes	2	1	2	4
	1.25"/1.25"/32/32	2116	Grey	PE	45/-45	No	1	2	3	1
	1"/1"/25/25	2117	Grey	PE	45/-45	No	1	2	3	1
Inter, sleeves	2"/1.5"/50/38	2131*	Black	PA12	284/-4/140/-20	Yes	1	2	3	1
	2"/1.5"/50/38 (PU)**	2160*	Black	PA12	284/-4/140/-20	Yes	1	2	3	1
	3"/2"/76/50	2100*	Black	EPDM	284/-76/140/-60	Yes	2	1	2	4
	2"/1.5"/50/38	2120*	Black	EPDM	284/-76/140/-60	Yes	2	1	2	4
Inter, sleeves	1.5"/1.25"/38/32	2121*	Black	EPDM	284/-76/140/-60	Yes	2	1	2	4
	1.25"/1"/32/25	2101*	Black	EPDM	284/-76/140/-60	Yes	2	1	2	4
	2"/50	2403	Grey	PE	45/-45	No	2	2	3	3
Hose connector	1.5"/38	2118	Grey	PE	45/-45	No	2	2	3	3
	1.25"/32	2119	Grey	PE	45/-45	No	2	2	3	3
	2"/50	2170*	Black	PA12	284/-4/140/-20	Yes	1	2	3	1
Hose connector	1.5"/38	2169*	Black	PA12	284/-4/140/-20	Yes	1	2	3	1
	1.25"/32	2168*	Black	PA12	284/-4/140/-20	Yes	1	2	3	1

* Antistatic is defined as having a conductivity of < 10⁹ Ω

To order an antistatic ESD version, add the letter E to the end of the part No.

** The wire helix must be bared and left in contact with conductive material

Resistance Scale

- 1 Excellent
- 2 Good
- 3 Limited
- 4 Poor

Cleaning accessories

For the best results when cleaning, it is necessary to have the right equipment and to use it in the correct way. It is therefore a prerequisite that a variety of different accessories are available for different tasks. 1.25"/32 mm cleaning accessories are recommended when very light tools are required e.g.: office cleaning. 1.5"/38 mm cleaning tools are ideal in most cases, they combine good capacity with ease of handling. Everything is available, from light tools such as wands in aluminium and

tools in plastic and rubber, to sturdy wear resistant wands in steel and cast aluminium floor tools. 2"/50 mm cleaning accessories are used for very heavy cleaning. Aluminium wands, large wheels on the floor tools and the ERGO-grip are several of the details which allow the accessories to be used easily despite their size. 3"/76 mm accessories are used for different types of material transport.



Cleaning accessory Ø 0,98"/25 mm

The In-line swivel attaches to dust collection casings with a 1" diameter inlet for hand tools. When used operators enjoy increased flexibility and decreased resistance. The in-line swivel is made of antistatic plastic.

Part No 2136 In-Line Swivel



In-line Swivel 2136

Cleaning accessories Ø 1.25"/32



Part No	Description
2048	Hose set L=24'/8 m w hand pipe
7292	Suction brush 1.25"/32 mm
7293	Floor Tool 10.5/270 mm P-1.25"/32 mm
7294	Chromed Wand 1.25"/32 mm L=970 mm, telescopic
7358	Suction brush 1.25"/32 mm
7399	Flat nozzle, 1.25"/32 mm
7464	Rectangle brush 1.25"/32 mm



Technical data

Q_{nom}	90 cfm/150 m ³ /h
Δp_{nom}	28 inwg/7 kPa

Cleaning accessories Ø 1.5"/38 mm

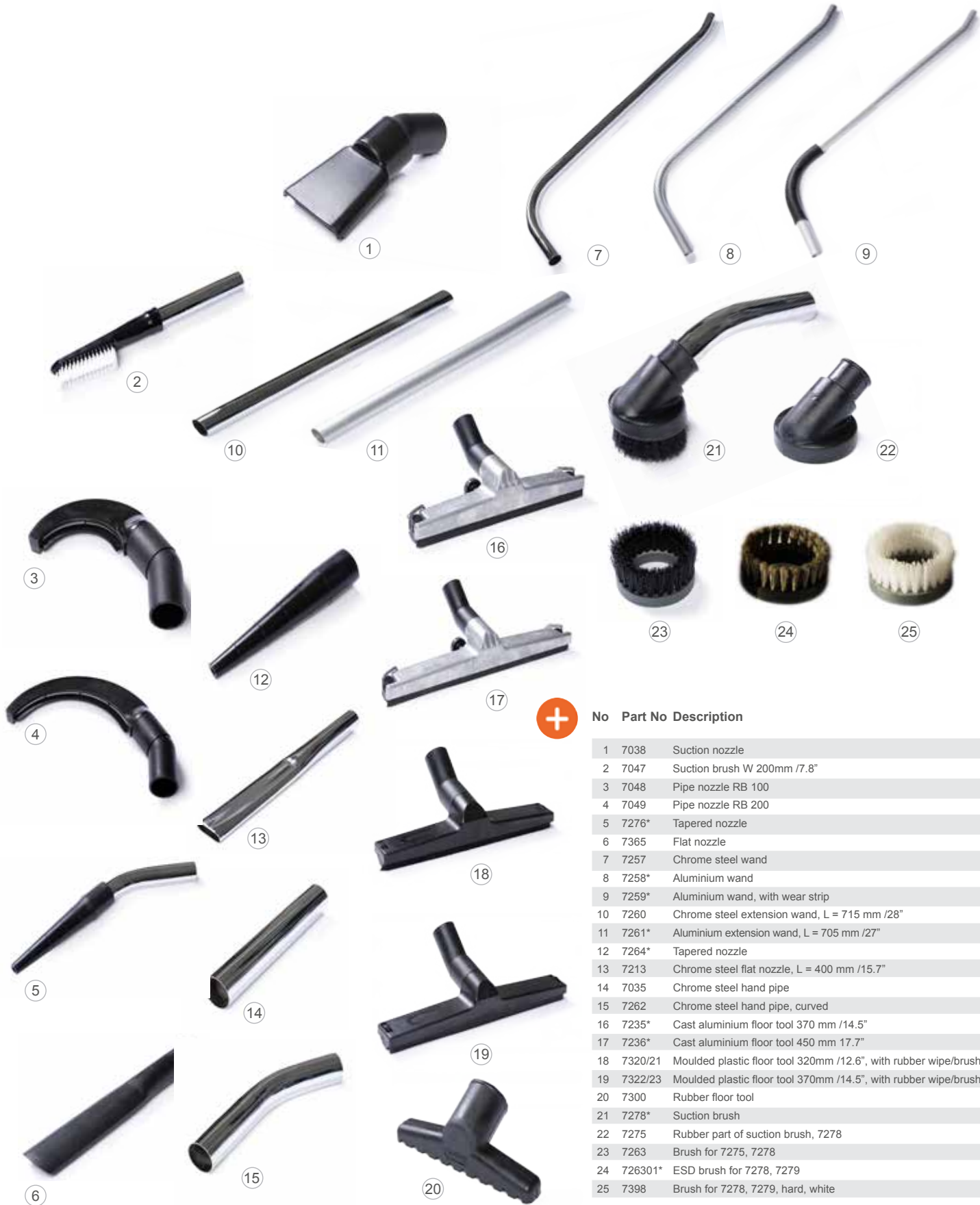

No Part No Description

1	7038	Suction nozzle
2	7047	Suction brush W 200mm /7.8"
3	7048	Pipe nozzle RB 100
4	7049	Pipe nozzle RB 200
5	7276*	Tapered nozzle
6	7365	Flat nozzle
7	7257	Chrome steel wand
8	7258*	Aluminium wand
9	7259*	Aluminium wand, with wear strip
10	7260	Chrome steel extension wand, L = 715 mm /28"
11	7261*	Aluminium extension wand, L = 705 mm /27"
12	7264*	Tapered nozzle
13	7213	Chrome steel flat nozzle, L = 400 mm /15.7"
14	7035	Chrome steel hand pipe
15	7262	Chrome steel hand pipe, curved
16	7235*	Cast aluminium floor tool 370 mm /14.5"
17	7236*	Cast aluminium floor tool 450 mm 17.7"
18	7320/21	Moulded plastic floor tool 320mm /12.6", with rubber wipe/brush
19	7322/23	Moulded plastic floor tool 370mm /14.5", with rubber wipe/brush
20	7300	Rubber floor tool
21	7278*	Suction brush
22	7275	Rubber part of suction brush, 7278
23	7263	Brush for 7275, 7278
24	726301*	ESD brush for 7278, 7279
25	7398	Brush for 7278, 7279, hard, white



* To order an antistatic (ESD) version, add E to the end of part no.

Cleaning accessories Ø 2"/50 mm



ERGO Grip for better handling.
Fits on all Ø50 /2" wands and
Ø50 /2" bulk nozzle.



No Part No Description

No	Part No	Description
1	7266	Aluminium wand
2	7267	Aluminium wand, with wear strip
3	7265	Chrome steel wand
4	7268/69	Chrome steel extension wand, 710 mm/28" Aluminium extension wand, 710 mm/28"
5	7033	Chrome steel hand pipe
6	7271	Chrome steel hand pipe, curved
7	7285	ERGO Grip handle
8	7272*	Tapered nozzle
9	7277*	Tapered nozzle
10	7212	Flat nozzle, L = 400 mm /15.7"
11	7295	Bulk nozzle
12	7013	Rubber floor tool
13	7281*	Floor nozzle W 200 mm /7.8"
14	7238*	Cast aluminium floor tool, 500 mm/19.6"
15	7307	Gulper floor tool, aluminium
16	7149	Chip nozzle 50x70x243 / 1.9"x2.7"x9.6"
17	7030	Suction nozzle
18	7279*	Suction brush
19	7016*	Suction nozzle with brush
20	7275	Rubber part for suction brush
21	7263	Brush for 7274, 7279
22	726301*	ESD brush for 7278, 7279
23	7398	Brush for 7278, 7279, hard, white



* To order an antistatic (ESD) version,
add E to the end of part no.

Cleaning accessories Ø 3"/76 mm

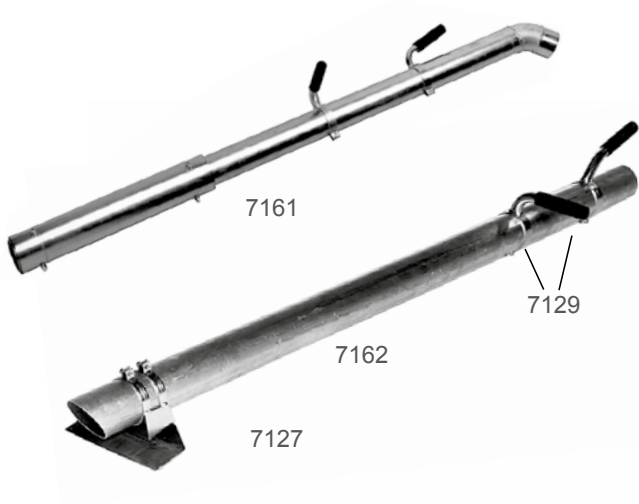

Part No	Description
7126	Clamp for scraper
7127	Scraper for suction lance
7129	Handle, complete
7161	Bulk nozzle
7162	Suction lance



Spare Parts for Floor Tools

Moulded Plastic Floor Tools Ø 1.5"/38

		B = 12.6" /320 mm		B = 14.6" /370 mm			
	Set		7320	7321		7322	7323
A	Rubber band B 316/288 (2 pcs)	7328	x	–	7329	x	–
B	Front brush	7225	–	x	7226	–	x
C	Rear brush	7326	–	x	7327	–	x
D	Brush holder	7215	x	x	7216	x	x
E	Brush holder	7324	x	x	7325	x	x
F	Wheel, floor nozzle P	40455	x	x	40455	x	x

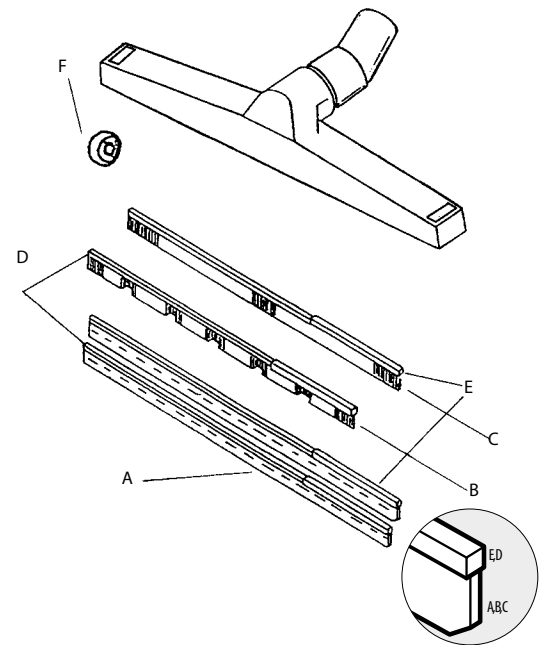

Cast Alu Floor Tools Ø 1.5"/38 mm, Ø 2"/50 mm

		Ø 1.5"/38 mm		Ø 2"/50 mm			
		B = 14.6" /370 mm		B = 17.7" /450 mm		B = 19.7" /500 mm	
	Set		7235		7236		7238
A	Rubber band* (2 pcs)	7045	x	7014	x	7051	x
B	Front brush	7222	–	7223	–	7224	–
C	Rear brush	7225	–	7228	–	7227	–
D	Brush holder	7216	x	7218	x	7219	x
E	Brush holder	7215	x	7217	x	7218	x
F	Cover 370 A	7242	x	7243	x	7244	x
G	Wheel, floor nozzle A	7252	x	7252	x	7252	x
H	Clamp	7239	x	7240	x	7241	x
I	Adjusting screw	7253	x	7253	x	7253	x
J	Coned connection, antistatic	7335	x	7335	x	7245	x

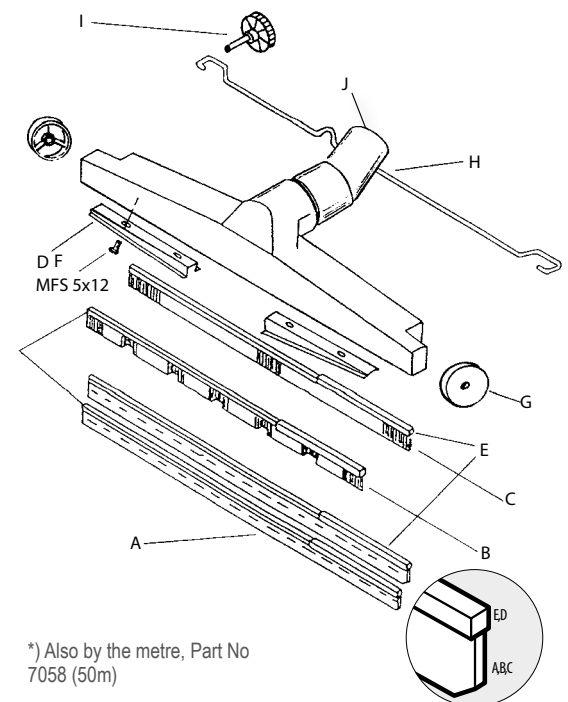

Gulper Floor Tools Ø 2"/50 mm, Alu

	B = 15.7"/400 mm	B = 17.7"/450 mm
Set		7307
Rubber moulding (2 pcs)	7108	x
Brush B 450/420	7046	x
Brush holding moulding	7115	x
Brush holding moulding	7116	x
Wheel kit	7146	x

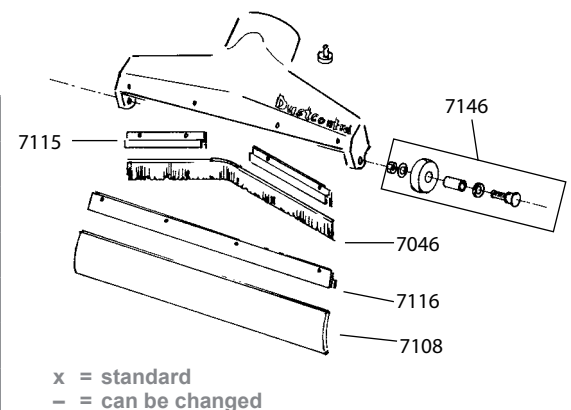

Welding accessories/Extraction nozzles



Technical data

Part No	Description	Connection (Ø) (in/mm)	Qnom	Δpnom
4149	Suction nozzle	2"/50	150 cfm/250 m³/h	6.4 inwg/1.6 kPa
6005	Universal nozzle	1.5"/38	90 cfm/150 m³/h	6.4 inwg/1.6 kPa
6098	Tubular nozzle	1.5"/38	90 cfm/150 m³/h	15.2 inwg/3.8 kPa
6610	Universal nozzle	1.5"/38	90 cfm/150 m³/h	6.4 inwg/1.6 kPa
6616	Universal nozzle Ø 50	2"/50	250 m³/h	6.4 inwg/1.6 kPa
7148	Funnel shaped nozzle Ø 50	2"/50	150 cfm/250 m³/h	6.4 inwg/1.6 kPa
7150	Magnetic holder for 7148, 4149	2"/50	90 cfm/150 m³/h	10.8 inwg/2.7 kPa



4149



6005



6098



6610



6616

















7148

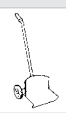

7150

Containers and Accessories

Part No	Description	Volume/ height	Capacity	Picture	DC 1800*	DC 2900a	DC 3800a/i	DC 5900a/i	Comments
42278-70	Container	20 l/5 gal 285 mm	40 kg/90 lbs		X				Is delivered complete with wheels undercarriage and fasteners.
40070	Container	40 l/10.5 gal 402 mm	60 kg/130 lbs		X*	X	X		–
40409	Container with sight glass	40 l/10.5 gal 402 mm	60 kg/130 lbs		X*	X	X		Steel container with sight glass and knockout for drain tap.
40624	Container, stainless	40 l/10.5 gal 402 mm	60 kg/130 lbs		X*	X	X		Stainless steel container for liquids.
40412	Container with sight glass	60 l/15.5 gal 685 mm	60 kg/130 lbs		X*	(X)**	(X)**	X	Steel container with sight glass and knockout for drain tap. The cyclone must be raised to a higher mounting point with the above kit.
42369	Basket for plastic bag				X				Ensures that the bag cannot get drawn to the filter when the machine is used for light material.
4119	Drain tap 40/60 l				X	X	X	X	The drain tap is mounted on the 40 l with sight glass. R 1/2
40410	Bottom screen 40/60 l				X	X	X	X	For fluid separation; The bottom screen is installed in the bottom and the drain tap is mounted on the container, 40/60 l.
40401	Carrying handles 40 l				X	X	X	X	Heavy duty carrying handles are installed in place of the standard locking hooks. For 40 l containers.
7313	Emptying car 40/60 l				X	X	X	X	Emptying cart for easy handling of the container.
42078	Lifter kit 60 l							X	When the 60 l container is to be used, the cyclone must be raised on the units chassis.
7368	Container	75 l/19.5 gal						X	
7249	Container with sight glass	90 l/23.5 gal 700 mm	150 kg/330 lbs					X	The cyclone is mounted in the higher mounting position and the bottom cone is changed.
7314	Container with sight glass, drain tap and bottom screen	90 l/23.5 gal 700 mm	150 kg/330 lbs					X	The cyclone is mounted in the higher mounting position and the bottom cone is changed.
7248	Emptying cart 90 l							X	The cart for handling of the 90 l container can also be handled with a fork lift. The container is rotated for emptying.
42079	Bottom cone kit, 90 l, and extension hose							X	With the 90 l container the cyclone must be mounted at a higher position on the chassis and the bottom cone changed.
7315	Crane hook 90 l							X	The crane hook is mounted securely on the 90 l container. The container can be rotated for emptying in the elevated position.

*) Max 90 lbs/40 kg when fitted to a DC 1800

**) Fits to the cyclone but not to the standard chassis

Plastic Bags

Machine	Standard	Antistatic/ESD	Volume (gal/litre)	Size (in/mm)
DC 1800	42291*	42951****	4 /15	21.7"x21.7" /550 x 550 mm
DC 2900c	42702*		5 /20	17"x 21.7" /440 x 550 mm
DC 2800H Asbestos	42285****	42384****	10.5 /40	14"x27.5" /360 x 700 mm
DC 3800 H Asbestos	42285****	42384****	10.5 /40	14"x27.5" /360 x 700 mm
DC 3900c	43619*	42384****	10.5 /40	19.7"x33.5" /500 x 850 mm
DC 3900L	432177 Longopac**		-	65 ft /20 m
DC 3900c Twin	43619*	42384****	10.5 /40	19.7"x33.5" /500 x 850 mm
DC 3900L Twin	432177 Longopac**		-	65ft /20 m
DC 3900L Twin	43619*	42384****	10.5 /40	19.7"x33.5" /500 x 850 mm
DC 3900c Turbo	43619*	42384****	10.5 /40	19.7"x33.5" /500 x 850 mm
DC 3900c Twin Turbo	43619*	42384****	10.5 /40	19.7"x33.5" /500 x 850 mm
DC TROMB 400 c	43619*	42384****	10.5 /40	19.7"x33.5" /500 x 850 mm
DC TROMB 400 L	432177 Longopac**		-	65 ft /20 m
DC 3800 Wood Shavings Extractor	4714***		23 /90	27.5"x43.3" /700 x 1100 mm
DC 4000 PCB	42285****		5 /20	14"x27.5" /360 x 700 mm
DC 5900 c	46145*		15.5 /60	25.2"x39.4" /640 x 1000 mm
DC 5900 L	44077 Longopac		-	65 ft /20 m x 1
Stationary dust extractors				
S 11000	4714/44078	42111***	23 gal/90 l	27.5" x 33.5"/700 x 850 mm/ 27.5" x 43.3"/700 x1100 mm
S 21000	4714	42111***	23 gal/90 l	27.5" x 43.3"/700 x 1100 mm
S 32000	4714	42111***	23 gal/90 l	27.5" x 43.3"/700 x 1100 mm
S 34000	4714	42111***	23 gal/90 l	27.5" x 43.3"/700 x 1100 mm
S 34000X	4714	42111***	23 gal/90 l	27.5" x 43.3"/700 x 1100 mm
Filter bag, Wet-Vac				
DC 50W	42190			
DC 75W	42190			
Pre-Separators				
DC F 8000c	46145*		15.5 /60	25.2"x39.4" /640 x 1000 mm
DC F 8000L	44077 Longopac		-	65 ft /20 m
DC F 2800c	42702*		5 /20	17"x 21.7" /440 x 550 mm
DC F 3900c	43619*		10.5 /40	19.7"x33.5" /500 x 850 mm
DC F 3900L	432177 Longopac**		-	65 ft /20 m x 1
DC F Mobil	4714	42111***	23 gal/90 l	27.5" x 43.3"/700 x 1100 mm
F 20000	4714	42111***	23 gal/90 l	27.5" x 43.3"/700 x 1100 mm
F 30000	4714	42111***	23 gal/90 l	27.5" x 43.3"/700 x 1100 mm

* Bags are sold in pcss of 10

** Bags are sold in pcss of 4

*** Bags are sold in pcss of 50

**** Bags are sold individually

All plastic bags are manufactured in strong LD-polyethylene.
Bag strap, part no 4313, 1 m, part no 4613, 1.5 m.

Suction Casings



Finding the right suction casing

Machine	Make	Type
D	d	H h A B M

Legend

- F Fibre disc
- D Diamond cup grinding disc
- N Depressed centre disc
- K Abrasive disc, diamond disc
- S Abrasive cup stone

If you cannot find the suction casing you are looking for, contact your sales representative for pricing information regarding a product tailored to your specific needs.

F
Fibre Disc

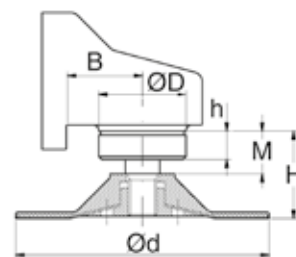

D
Diamond Cup
Grinding Disc

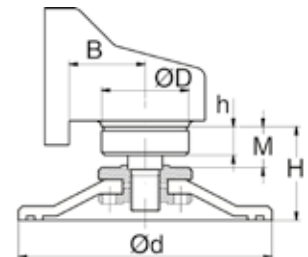

N, K
Depressed Centre Disc,
Abrasive Disc, Diamond Disc

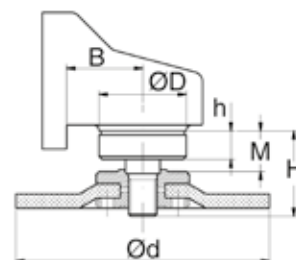

S
Abrasive Cup Stone

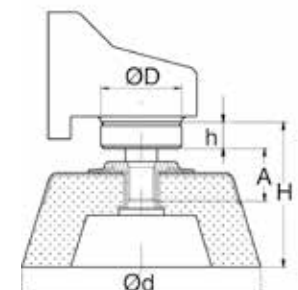

Suction Casings

Suction Casing Kit for Fibre Discs (F)

1

Measure the diameter of the disc



2

Measure the diameter of the mounting collar on the machine - ØD and the height of the machine - H

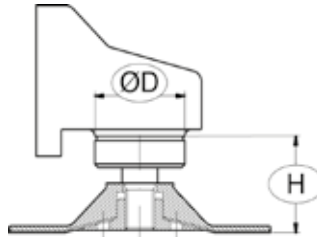

3



Technical data

Disc diameter	Ø D	H	Connection, Ø	Part No.
1½–3" (38–75 mm)	1.1"/27	*	1.25"/32 mm	6833*
4" (100 mm)	1.6"–1.9"/40–49	1.5"–1.7"/39–44 mm	1.25"/32 mm	6670
4½" (115 mm)	1.6"–1.9"/40–49	1.5"–1.9"/39–48 mm	1.25"/32 mm	6671
5" (125 mm)	1.6"–1.9"/40–49	1.5"–1.9"/39–48 mm	1.25"/32 mm	6672
5" (125 mm)	2"/50	1.5"–2.1"/38–61 mm	1.25"/32 mm	6673
7" (175 mm)	2.1"–2.4"/54–61	2"–2.3"/50–59 mm	1.5"/38 mm	6674
7" (175 mm)	2.4"–2.6" & 2.9"–3" /62–65 & 74–77	2"–2.9"/50–73 mm	1.5"/38 mm	6675

** Some Hitachi machines have a Ø40 mm /1.6" conical neck. With these, it is necessary to buy an aluminium ring (part no. 6270). When fitted on the machine, this aluminium ring enlarges the ØD of the machine to 50 mm /1.9" – therefore choose the 5" N, K suction casing kit – part no. 6678.



Suction Casings

Suction Casing Kit for Diamond Cup Grinding Discs (D)

1

Measure the diameter of the disc



2

Measure the diameter of the mounting collar on the machine - $\varnothing D$ and the height of the machine - H

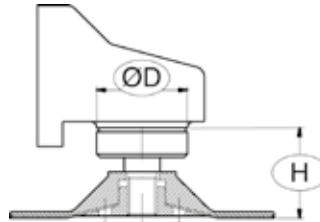

3



Technical data

Disc diameter	$\varnothing D$	H	Connection, \varnothing	Part No
4½" (115 mm)	1.6"-1.9"/40-49 mm	1.9"-2.1"/49-54 mm	1.25"/32 mm	6681
5" (125 mm)	1.6"-1.9"/40-49 mm	1.9"-2.8"/49-70 mm	1.25"/32 mm	6682
5" (125 mm)	2"/50 mm	1.5"-2.4"/38-61 mm	1.25"/32 mm	6673
7" (175 mm)	2.1"-2.4"/54-61 mm	2.5"-2.8"/63-72 mm	1.5"/38 mm	6683
7" (175 mm)	2.4"-2.6" & 2.9"-3" / 62-65 & 74-77 mm	2.5"-3.4"/63-86 mm	1.5"/38 mm	6684



Suction Casings

Suction Casing Kit for Depressed Centre Discs, Abrasive Discs and Diamond Discs (N, K)

1

Measure the diameter of the disc



Note: Max. thickness of disc = 18 mm.

2

Measure the diameter of the mounting collar on the machine $\varnothing D$ and the height of the machine - H.

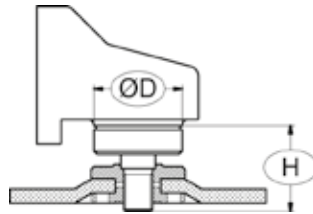

3

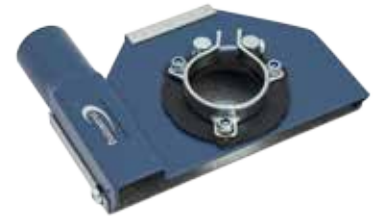

Technical data

Disc diameter	$\varnothing D$	H	Connection, \varnothing	Part No.
4 1/2" (115 mm)	1.6"-1.9"/40-49 mm	1.2"-1.8"/31-46 mm	1.25"/32	6676
5" (125 mm)	1.6"-1.8"/40-45 mm	1.2"-1.8"/31-46 mm	1.25"/32	6677**
5" (125 mm)	1.8"-2.1"/46-53	1.2"-1.8"/31-46 mm	1.25"/32	6678
7" (175 mm)	2.4"-2.6" & 2.9"-3"/62-65 & 74-77 mm	1.2"-2"/31-51 mm	1.5"/38	6679
9"*	4.4"/112 mm	1.5"/37 mm	1.5"/38	6221*
9"	2.7"/68 mm	2"/51 mm	1.5"/38	6202*
9"	2.9"/74 mm	2.1"/54 mm	1.5"/38	6302*
9"	2.9"/74 mm	1.5"/37 mm	1.5"/38	6349*
9"	2"/50 mm	1.9"/47 mm	1.5"/38	6500*
9"	2.4"/62 mm	2.1"/54 mm	1.5"/38	6416*
9"	2.4"/62 mm	2"/50 mm	1.5"/38	6438*
9"	2.4"/62 mm	1.9"/48 mm	1.5"/38	6555*
9"	2.6"/65 mm	1.6"/40 mm	1.5"/38	6842*
9"	2.5"/64 mm	2"/52 mm	1.5"/38	6427*
9"	2.3"/58 mm	2.1"/54 mm	1.5"/38	6537*
Georges Renault KL 365	9"	2.3"/59 mm	1.5"/38 mm	6388*

* With the clamping rings welded on the suction casings.

** Some Hitachi machines have a $\varnothing 40$ mm conical neck. With these, it is necessary to buy an aluminium ring (part no 6270). When fitted on the machine, this aluminium ring enlarges the $\varnothing D$ of the machine to 50 mm – therefore choose the 5" N, K suction casing kit – part no 6678.

Connection \varnothing

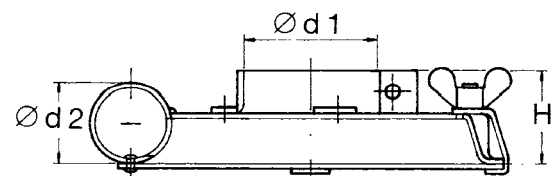

Suction Casings

Suction Casing Kit for Abrasive Cup Stone (S)

1

Measure the diameter of the disc



2

Measure the diameter of the mounting collar on the machine $\varnothing D$ and the height of the machine - H.

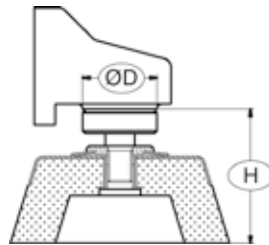

3



Technical data

Disc diameter	$\varnothing D$	H	Connection, \varnothing	Part No
5" (125 mm)	1.9-3"/ 50-77 mm	1.8-3.2"/46-81 mm	1.5"/38 mm	6680
6" (150 mm)	74-77 mm	46-81 mm	1.5"/38 mm	6023

Reciprocating Saw – Suction casings C



Technical data

Machine model	Connection, \varnothing (mm)	Part No
Atlas Copco SSE 1000 X/SQ/, Milwaukee 65xx-xx (Sawzall)	1.5" /32	6290
Milwaukee 6378	1.5" /32	6269

Suction Casings

Suction Casing for Hammer Drills, Chisels and Breakers



Part No 7033 Chrome steel hand pipe Ø50



+ Suction casings B, H, M, L

No	Part No	Connection tool Ø	Hose connection Ø	Height
1	6621	1.89"/48 mm	1.5"/38 mm	6.22"/158 mm
2	6622	1.69"/43 mm	1.5"/38 mm	6.22"/158 mm
3	6077	1.26"/32 mm	1.26"/32 mm	4.4"/112 mm
4	6078	2.4"/61 mm	1.5"/38 mm	7"/178 mm
5	6001 (7033)	-	2"/50 mm	3.9"/100 mm
6	6130	Bellow for 6078, 6621 and 6622		

Part no 6622 and 6077 are suitable for small chisel hammers.

+ Model-specific suction casings

Part No	Model	Hose connection Ø
6229	Atlas Copco RRD 37/RRD 57	1.5"/38 mm
6152	Atlas Copco BBD 11/RRC 73	1.5"/38 mm

Suction Casings Spare Parts for Suction Casings

	Description	Dimension			Part No.	
			D1 in/mm	D2 in/mm		H in/mm
	Plastic ring for saucer grinder	5S 6S	4.8"/121 5.8"/147	5.5"/139 6.5"/164	2"/50 2"/50	6003 6004
	Rubber collar for fibre disc (F)	1 ½ F 2 F 3 F 4 F 4 ½ F 5 F	1.5"/39 1.5"/39 1.5"/39 2.8"/72 2.8"/72 2.8"/72	2.3"/59 2.7"/69 3.7"/95 4.6"/117 5.3"/135 5.3"/135	0.9"/23 0.9"/23 1" /25 0.5"/13 0.5"/13 0.9"/23	6314 6313 6312 6182 6181 618100 6195
	Rubber collar for fibre disc (F)	5 F	3.8"/96	5.9"/150	0.6"/15	6006
	Rubber collar for oscillating sanding machine	5 O 6 O	2.8"/72 3.8"/96	5.7"/145 6.7"/170	1.5"/38 1.1"/28	6212 6180
	Rubber collar for fibre disc (F)	7 F 7 F 8 F 9 F	4.4"/112 4.4"/112 4.4"/112 4.5"/113	7.7"/196 7.7"/196 8.7"/221 10"/250	7"/19 1.4"/35 1.6"/41 1.25"/32	6002 6034 6211 6039

Suction Casings Customized Suction Stationary Casings

Dustcontrol can customize the suction casing to suit the production process.



Robot deburring for telecom parts



Food packing industry



Suction casing mounted on slitter knife in printing press



Suction casing mounted on slitter knife in printing press



Filters

Cellulose Fine Filter

High-quality, standard filter with high filtration efficiency. Epoxy-treated for improved resistance to humidity and other elements.

Polyester Fine Filter

High-quality filter with exceptional resistance to most elements. Particularly suitable for applications where there is high humidity, for example in machining and tooling shops where cutting and cooling fluids are used. The filter can be washed.

HEPA H13 Filter

On many models a separate HEPA filter is fitted, after the fine filter. The HEPA filter is made of fibreglass with a support layer of cellulose. The filtration efficiency is 99.9%, according to EN 1822-1 ensures that even the smallest particles are separated. In applications requiring special filter materials, standard filter configurations can be ordered with alternative materials.

Note: When replacing filters, the filter holder gasket must always be checked and cleaned. Check that there are no leaks.

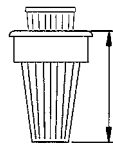

Conical pleated filter with sealing flange and protective jacket. The separate HEPA filter is fitted inside the fine filter.

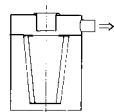

Conical pleated filter with sealing flange.

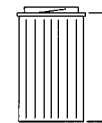

Cylindrical pleated filter with bayonet fitting.

DC 1800, DC 2900, DC 3800 Wood Shavings Extractor

Part No	Description	Construction	Material	Area ft ² /m ²	Classification	Max temp
42029	Fine filter	Pleated around support cylinder	Cellulose, epoxy-treated	16.2 /1.5	IEC EN 60335-2-69 Part 1	176°F/80°C
42029ST	Fine filter x 48		Cellulose			
42028	Fine filter	Pleated	Polyester	16.2 /1.5	IEC EN 60335-2-69 Part 1	176°F/80°C
42027	HEPA filter	Pleated	Cellulose, fibreglass	9.1 /0.85	HEPA H13 EN 1822-1	176°F/80°C
40479	Combi-filter (Fine filter + HEPA filter), (GS Asbestos)	Pleated	Cellulose, epoxy-treated	16.2 /1.5	HEPA H13 EN 1822-1	176°F/80°C

Filters

DC Tromb 400

Part No	Description	Construction	Material	Area ft ² /m ²	Classification	Max temp
44017	Fine filter	Pleated around support cylinder	Polyester	27 /2.5	IEC EN 60335-2-69 Part 1	176°F/80°C
44043	Fine filter	Pleated around support cylinder	Cellulose, epoxy-treated	27 /2.5	IEC EN 60335-2-69 Part 1	176°F/80°C
44016	HEPA filter	Pleated	Cellulose, fibreglass	23.7 /2.2	HEPA H13 EN 1822-1	176°F/80°C

DC 3900 Series & DC 4000 PCB

Part No	Description	Construction	Material	Area ft ² /m ²	Classification	Max temp
42026	Fine filter	Pleated around support cylinder	Cellulose, epoxy-treated	19.4/ 1.8	IEC EN 60335-2-69 Part 1	176°F/80°C
42026ST	Fine filter x 24		Cellulose			
42025	Fine filter	Pleated	Polyester	19.4/ 1.8	IEC EN 60335-2-69 Part 1	176°F/80°C
42025ST	Fine filter x 24		Polyester			
42465	Fine filter, PTFE	Pleated around support cylinder	Polyester, PTFE	19.4/ 1.8	IEC EN 60335-2-69 Part 1	176°F/80°C
42024	HEPA filter	Pleated	Cellulose, fibreglass	16/ 1.5	HEPA H13 EN 1822-1	176°F/80°C
42398	Fine filter	Pleated around support cylinder	Polyester	19.4/ 1.8	IEC EN 60335-2-69 Part 1	176°F/80°C
4202501	Fine filter		Antistatic	16.2 /1.5		176°F/80°C

DC 5900 Series

Part No	Description	Construction	Material	Area ft ² /m ²	Classification	Max temp
429203	Fine filter, PTFE	Pleated around support cylinder	Polyester, PTFE	53.8/ 5.0	IEC EN 60335-2-69 Part 1	266°F /130°C
429204	Fine filter	Pleated around support cylinder	Polyester	53.8/ 5.0	IEC EN 60335-2-69 Part 1	266°F /130°C
4292	Fine filter	Pleated around support cylinder	Polyester	90.4/ 8.4	IEC EN 60335-2-69 Part 1	266°F /130°C
42869	HEPA filter, DC 5900 4 kW, 9.2 kW S (installed under top cover)	Pleated around support cylinder	Cellulose, fibreglass	29/ 2.7	HEPA H13 EN 1822-1	176°F/80°C
42807	HEPA filter, DC 5900c 9.2 kW P (x 2/machine) (installed on exhaust)	Pleated	Cellulose, fibreglass	39.8/ 3.7	HEPA H13 EN 1822-1	176°F/80°C

DC AirCube Series

Part No	Description	Construction	Material	Area ft ² /m ²	Classification	Max temp
42896	HEPA filter AC2000	Pleated around support cylinder	Cellulose, fibreglass	107.6/ 10	HEPA H13 EN 1822-1	122°F /50°C
42917	Pre-filter AC2000	Cartridge	Polyester	53.8/ 5.0	G3	122°F /50°C
42690	Pre-filter AC500	Pleated carpet	Polyester	2/ 0.18	G3	176°F/80°C
42692	HEPA filter AC500	Pleated	Cellulose, fibreglass	45/ 4.2	HEPA H13 EN 1822-1	176°F/80°C
42918	Pre-filter AC1200	Cartridge	Polyester	4.3/ 0.4	G3	176°F/80°C
42940	HEPA filter AC1200	Pleated	Cellulose, fibreglass	59/ 5.5	HEPA H13 EN 1822-1	176°F/80°C

Filter Units, S 11000, S 32000, S 34000, S 34000X, S 46000

Part No	Description	Construction	Material	Area ft ² /m ²	Classification	Max temp
4292	Fine filter, S 11000, S 32000, S 34000	Pleated around support cylinder	Polyester	90.4 /8.4 m ²	IEC EN 60335-2-69 Part 1	266°F /130°C
4284	Fine filter, S 11000X, S 21000, S 34000X, S 46000	Pleated around support cylinder	Polyester	129.2 /12 m ²	IEC EN 60335-2-69 Part 1	266°F /130°C
42807	HEPA filter, S 11000 HEPA, S 11000X HEPA, HEPA-Module	Pleated around support cylinder	Cellulose, fibreglass	39.8 /3.7 m ²	EN 1822-1, HEPA H13	176°F /80°C
42896-1	HEPA filter, DC HEPA box	Pleated around support cylinder	Cellulose, fibreglass	109.8/10.2 m ²	EN 1822-1, HEPA H13	194°F /90°C
429206	Fine filter, antistatic, S 11000EX, S 21000EX, S 34000EX	Pleated around support cylinder	Polyester	90.4 /8.4 m ²	IEC EN 60335-2-69 Part 1	266°F /130°C

Filters for earlier models

DC 2500i, DC 2500, DC 2500 Twin

Part No	Description	Construction	Material	Area ft ² /m ²	Classification	Max temp
4889	Fine filter	Pleated	Polyester	15 /1.4	IEC EN 60335-2-69 Part 1	266°F /130°C
404901	Fine filter	Pleated around support cylinder	Cellulose	16.2 /1.5	IEC EN 60335-2-69 Part 1	158°F /70°C
4821	HEPA filter K	Pleated	Cellulose, fibreglass	16.2 /1.5	HEPA H13 EN 1822-1	158°F /70°C
4133	HEPA filter (fitted in the fine filter)	Pleated around support cylinder	Cellulose, fibreglass	5.4 /0.5	HEPA H13 EN 1822-1	176°F/80°C

DC 2700c, DC 2700i, DC 2800c, DC 2800c Rental

(Machines from serial number 2527595 can be equipped with the new, separate HEPA filter (Part No 42027). Older models should be equipped with a HEPA combi-filter.

Part No	Description	Construction	Material	Area ft ² /m ²	Classification	Max temp
4889	Fine filter	Pleated	Polyester	15 /1.4	IEC EN 60335-2-69 Part 1	266°F /130°C
404901	Fine filter	Pleated around support cylinder	Cellulose	16.2 /1.5	IEC EN 60335-2-69 Part 1	158°F /70°C
4821	HEPA filter K	Pleated	Cellulose, fibreglass	16.2 /1.5	HEPA H13 EN 1822-1	158°F /70°C
4133	HEPA filter (fitted in the fine filter)	Pleated around support cylinder	Cellulose, fibreglass	5.4 /0.5	HEPA H13 EN 1822-1	176°F/80°C

DC 3700c

Part No	Description	Construction	Material	Area ft ² /m ²	Classification	Max temp
42026	Fine filter	Pleated around support cylinder	Cellulose, epoxy-treated	19.4 /1.8	IEC EN 60335-2-69 Part 1	176°F/80°C
42025	Fine filter	Pleated	Polyester	19.4 /1.8	IEC EN 60335-2-69 Part 1	176°F/80°C

Filters for earlier models

DC 3500, DC 3500 TR, DC 3500 Stationary, DC 5500, DC 5500i

Part No	Description	Construction	Material	Area ft ² /m ²	Classification	Max temp
408801	Fine filter	Pleated	Polyester	17 /1.6	IEC EN 60335-2-69 Part 1	176°F/80°C
408803	Fine filter	Pleated	Cellulose	17 /1.6	IEC EN 60335-2-69 Part 1	176°F/80°C
4821	HEPA filter, DC 3500 TR	Pleated	Cellulose, fibreglass	16.2 /1.5	HEPA H13 EN 1822-1	158°F /70°C
4366	HEPA filter, DC 3500 (installed on exhaust)	Pleated around support cylinder	Cellulose, fibreglass	12.9 /1.2	HEPA H13 EN 1822-1	176°F/80°C
4422	HEPA filter, DC 5500 5 kW, 9.2 kW S (installed under top cover)	Pleated around support cylinder	Cellulose, fibreglass	26.9 /2.5	HEPA H13 EN 1822-1	176°F/80°C
4017	HEPA filter, DC 5500 9.2 kW P (installed on exhaust)	Pleated	Cellulose, fibreglass	30 /2.8	HEPA H13 EN 1822-1	176°F/80°C

DC 3500i, DC 5700c, DC 5800 a/c 5 kW, DC 5800 a/c PTFE

Part No	Description	Construction	Material	Area ft ² /m ²	Classification	Max temp
4917	Combi-filter DC 3500i (Fine filter + HEPA H13 filter)	Pleated	Cellulose, fibreglass	16.2 /1.5	HEPA H13 EN 1822-1	176°F/80°C
4422	HEPA filter, DC 5700 5 kW, 9.2 kW S (installed under top cover)	Pleated around support cylinder	Cellulose, fibreglass	26.9 /2.5	HEPA H13 EN 1822-1	176°F/80°C
4017	HEPA filter, DC 5700 9.2 kW P (installed on exhaust)	Pleated	Cellulose, fibreglass	30 /2.8	HEPA H13 EN 1822-1	176°F/80°C

Air Cleaners, DC 380, DC 1500, DC AirCube

Part No	Description	Construction	Material	Area ft ² /m ²	Classification	Max temp
4080	Pre-filter, DC 380/DC AirCube	Carpet	Polyester	1 /0.1	IEC EN 60335-2-69 Part 1	212°F /100°C
4669	Pre-filter, DC 1500	Carpet	Polyester	3.2 /0.3	IEC EN 60335-2-69 Part 1	212°F /100°C
42136	HEPA filter, DC AirCube	Pleated HEPA filter box	Fibreglass	55.9/5.2	EN 1822-1, HEPA H13	176°F/80°C

DC 3800a/c, DC 3800c Turbo, DC 3800 Turbo EX, DC 3800c Twin

DC 3800 TR S, DC 3800i, DC 3800 Stationary

Part No	Description	Construction	Material	Area ft ² /m ²	Classification	Max temp
42026	Fine filter	Pleated around support cylinder	Cellulose, epoxy-treated	19.4 /1.8	IEC EN 60335-2-69 Part 1	176°F/80°C
42026ST	Fine filter x 24		Cellulose			
42025	Fine filter	Pleated	Polyester	19.4 /1.8	IEC EN 60335-2-69 Part 1	176°F/80°C
42025ST	Fine filter x 24		Polyester			
42465	Fine filter, PTFE	Pleated around support cylinder	Polyester, PTFE	19.4 /1.8	IEC EN 60335-2-69 Part 1	176°F/80°C
42024	HEPA filter	Pleated	Cellulose, fibreglass	16.2 /1.5	HEPA H13 EN 1822-1	176°F/80°C
42398	Fine filter, grounded	Pleated around support cylinder	Polyester	19.4 /1.8	IEC EN 60335-2-69 Part 1	176°F/80°C
4202501	Fine filter		Antistatic	16.2 /1.5		176°F/80°C

Dustcontrol's Environmental and Quality Policy

As an environmental company, we have a special responsibility as to how our products and services affect the environment – the external environment, our own working environment and that of our customers. We want to take responsibility for the environment as a whole. We therefore strive to comply with current environmental legislation and to constantly improve our own environmental work.

It is our responsibility to ensure that all employees are well qualified in environmental issues. We work to identify environmentally friendly modes of transport and company vehicles, and to minimise and separate – at source – the quantity of waste that arises in conjunction with manufacturing.

The entire production cycle is monitored, and we strive to make continuous improvements by finding environmentally friendly alternatives wherever possible. This can include anything from the use of environmentally friendly containers and packaging, to ensuring that the waste Bags are biodegradable. We use a method of powder coating that is free from solvents and minimises waste.

Dustcontrol adheres closely to the EU Reach and RoHS directives in order to reduce the use of chemicals to a minimum. We source only locally produced products for use in the manufacturing operation, in order to minimise freight costs and reduce CO₂ emissions. We operate with Lean Production to achieve the best possible process flow, with efficient utilisation of resources and reduced lead times.

Our quality should meet the requirements of our customers. This applies equally to product quality, delivery reliability and service. Our customers should know that we listen to their feedback in our ongoing efforts to improve the management system

We update our management system continuously, and Dustcontrol is certified according to ISO14001:2004 and ISO9001:2008.

"Technology for Healthy Business", is an approach that permeates our entire operation. For Dustcontrol, this means: sustainability, financial stability, efficient and effective solutions, physical health and a safe working environment.



Healthy Business

Dustcontrol[®]

INVISIBLE

THE HAZARDS ARE WHAT YOU CANNOT SEE

Our mission is to highlight the health concerns and consequences of not using the right equipment. We highlight the dangers — those tiny particles that penetrate deep into the lungs, causing lung cancer, asthma and chronic bronchitis, among other things. To be a leader in this industry you need a core issue. Ours is health. This campaign is the realisation of our brand promise. Technology for Healthy Business. We create products that solve the problems associated with unhealthy working environments and that eliminate the hazards the eye cannot see.

Visit dustcontrol.com to read more about how we can help you with what you can not see.

www.dustcontrol.com

Contact our Customer Service Department in our Head Office in Norsborg or visit our website for our worldwide distributors for further info, support, service or a demonstration.

Head Office

Dustcontrol AB
Box 3088 • Kumla Gårdsväg 14
145 03 Norsborg, Sweden
Telephone: +46(0)8 531 940 00
support@dustcontrol.se
www.dustcontrol.com

Download our catalogues from Dustcontrol.com



Save time – use QR codes

There are QR codes on all our mobile machines. Scan the code and you will be able to see videos on filter cleaning and how to replace filters and plastic bags.

No QR reader in your smartphone?
Download it from the App/Android store.



Which solution will you choose?

As a true professional, you have high requirements for your equipment. Dustcontrol has been involved with dust extraction and material transport for more than 40 years and we supply dust extractors and air cleaners for all types of applications. No matter what you choose, you can be sure of getting truly professional equipment that is built with your work environment and health in mind.

Dustcontrol QR Codes

Easily scanned using a smartphone, QR codes work like quick links, taking you straight to the information you need. We aim to make it easy for you to find information about our products, such as how to replace and clean the filter, or replace the bag. Our QR codes make it easy to find helpful instructional videos in the language of your choice, including English, Swedish, German or Finnish.

To scan the codes, you will need to download a QR code reader app. These can be obtained free of charge via the App Store, Android Market or similar platforms.

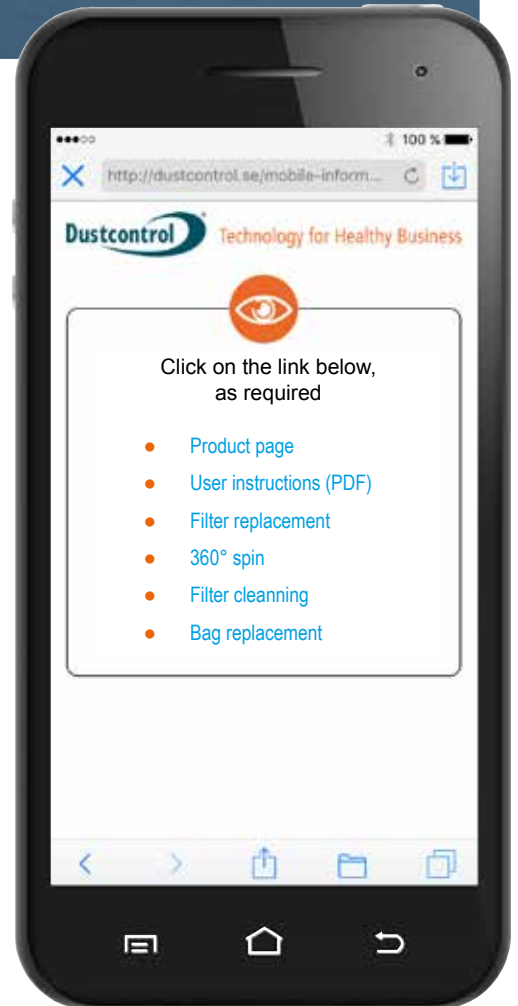

QR code Tromb



QR code DC 1800 & DC 2900



QR code AirCubes



QR code DC 5900





